

8,000 lb. Capacity

visit roadmasterinc.com/patents for patent information

Owner's Manual & Installation Instructions

Entire contents of manual must be read by owner

part number 576 (and 586 with Blue Ox arms)



Time Tested • Time Proven

ROADMASTER, Inc. • 6110 NE 127th Ave. • Vancouver, WA 98682
800-669-9690 • Fax 360-735-9300 • roadmasterinc.com
© 2007-2023 ROADMASTER, Inc. All rights reserved. 853326-35 09-23

WELCOME TO THE ROADMASTER FAMILY!

This manual has been prepared to acquaint you with the installation, operation, care and maintenance of your tow bar, and to provide you with important safety information.

Read your owner's manual cover to cover. Understand how to install and operate your tow bar, and carefully follow the instructions and safety precautions.

We thank you for your patronage and greatly appreciate your discerning taste.

Table of Contents

Safety definitions	inside front cover
Safe towing practices	1-2
Connecting and disconnecting	
Connecting the tow bar	3-4
Disconnecting the tow bar.....	5
Wiring instructions	6
Safety cables	
How to use safety cables.....	7
Proper installation of safety cables	8
Stay within the 'Safe Zone'.....	9
Care and cleaning	9
Tow bar components	back cover

Save this manual

Save this manual for future reference. It contains important sections relative to safety, use, maintenance, parts replacement and other information. Therefore, make sure this manual is always with you when you're towing. You may download or print a copy of the most current manual at www.roadmasterinc.com (under 'Support').

WARNING

Read all instructions before installing the tow bar or before towing a vehicle. Failure to understand how to properly install or operate the tow bar could result in property damage, personal injury or even death.



Your tow bar serial number...

...is located on a label on the inside of the driver's side tow bar arm. You will need this number when you fill out your product registration card.

Write down the serial number in the space below and retain for future reference.

Serial number: _____

All illustrations and specifications contained herein are based on the latest information available at the time of publication. ROADMASTER, Inc. reserves the right to make changes, at any time, without notice, in material, specifications and models, or to discontinue models.

IMPORTANT NOTICE! Safety Definitions

This manual contains information that is very important to know and understand. This information is provided for **safety** and to **prevent equipment problems**. To help recognize this information, observe the following symbols:

WARNING

WARNING indicates a potentially hazardous situation which, if not avoided, could result in property damage, serious personal injury or even death.

CAUTION

CAUTION indicates a potentially hazardous situation which, if not avoided, may result in property damage, or minor or moderate personal injury.

CAUTION

CAUTION used without the safety alert symbol indicates a potentially hazardous situation which, if not avoided, may result in property damage.

NOTE

Refers to important information and is placed in italic type. It is recommended that you take special notice of these items.

INSTALLER'S SAFETY CHECKLIST

- **Show the owner how to properly operate the tow bar.** Familiarize yourself with the features of the tow bar. Demonstrate them to the owner and ask the owner to connect and disconnect the tow bar and other components of the towing system, until the owner is comfortable with its operation.

- **Advise the owner to always use safety cables when towing.** The safety cables must connect the towed vehicle to the towing vehicle, frame to frame.

The capacity of the safety cables must meet or exceed the towed weight, or the safety cables will fail.

- **The tow bar must be attached to a baseplate which is bolted to the towed vehicle's frame or unibody.**

- **Read the instructions thoroughly before installing the tow bar and its components.** If the tow bar is not properly aligned, centered and positioned on the towed vehicle, then excessive tire wear and other consequential, non-warranty damage may result.

- **The installer must NOT use the tow bar as a ground for welding.** Connecting a ground to the tow bar will cause current to flow through the locking spring, which will temper the spring and destroy the locking mechanism.

- **Under no circumstances should the tow bar be welded to the vehicle,** nor should any of the pre-punched mounting holes be altered. Any welding or altering of the tow bar will void the owner's warranty.

WARNING

Failure to follow these instructions may cause property damage, personal injury or even death.

SAFE TOWING PRACTICES

CAUTION

Do not back up the motorhome with the towed vehicle attached.

Backing up with the towed vehicle attached will cause the towed vehicle to "jackknife," which will damage the tow bar, the baseplate, the receiver hitch, the towed vehicle's front end and/or the rear of the motorhome. Backing up with the towed vehicle attached is the primary cause of tow bar damage and will void the warranty.

- **Be sure the vehicle can be towed** before taking it on the road. Some vehicles must be equipped with a transmission lube pump, an axle disconnect, driveline disconnect or free-wheeling hubs before they can be towed. Failure to properly equip the vehicle will cause severe damage to the transmission.

Check the vehicle manufacturer's instructions for the proper procedure(s) to prepare the vehicle for towing.

- **The tow bar must be within the 'Safe Zone'** – no more than three inches above or below level. Towing with an out-of-level tow bar will cause significant wear and tear and may result in non-warranty failure and damages. (See the section titled "Stay within the 'Safe Zone'" for further information.)

- **The steering wheel must be unlocked and free to turn when towing.** Failure to do so can cause severe tire and equipment damage. Check the manufacturer's instructions for the proper towing procedure(s).

- **The towed vehicle and all its contents cannot exceed 8,000 pounds.** The Sterling tow bar is rated at a maximum of 8,000 pounds carrying capacity; therefore the towed vehicle and all its contents cannot exceed 8,000 pounds. In addition, the receiver hitch, the safety cables and all supplementary towing equipment must be rated at no less than the weight of the towed vehicle and all its contents.

- **The tow bar must be secured with linch pins (or optional padlocks) before towing.** Unless the tow bar is secured to both vehicles with all appropriate pins (or padlocks), the towed vehicle will detach.

- **Inspect the system before towing** – check the mounts, brackets, fasteners, bolts, wiring, the safety cables and all other components each time before towing. Additionally, check the baseplate every 3,000 miles – inspect for any fractures or cracks in the steel or any visible damage. Do not tow if the baseplate is damaged.

Additionally, check the torque on all bolts. (To find the torque ratings, refer to the installation instructions for the baseplate and the tow bar.)

- **This tow bar is designed for use on paved roads only.** ROADMASTER does not recommend off-road towing, nor does ROADMASTER warrant the tow bar for off-road use.

- **Never tow a vehicle with one of a comparable weight.** The towed vehicle's weight should never exceed 40 percent of the towing vehicle's weight.

Towing a vehicle with one of similar weight will cause the towed vehicle to override the towing vehicle, resulting in "jackknifing," "leapfrogging" or "fishtailing." Serious damage to both vehicles, as well as the towing system, could result.

- **Always stand to one side and as close to the motorhome as possible when releasing the tow bar locking mechanisms.** Never stand between the adjustable arms, or put any part of your body between the adjustable arms when releasing the tow bar – always stand to one side.

Because the towed vehicle may jerk forward when the locking mechanisms are released, face the towed vehicle and stand as close to the back of the motorhome as possible before releasing the locking mechanisms, to keep from being hit by the towed vehicle.

continued on next page

Safe towing practices

continued from preceding page

- **Do not drill a second hole in the shank of any tow bar or hitch accessory.** If the hole in the shank does not align to the hole in the hitch receiver: 1) purchase a hitch accessory of the appropriate length; or 2) call ROADMASTER technical support.

Drilling a second hole will weaken the steel. The shank may break during towing, which will cause the towed vehicle to separate.

- **Always use safety cables when towing.** The safety cables must connect the towed vehicle to the towing vehicle frame to frame.

Use only 8,000 pound or heavier rated safety cables. Additionally, check to ensure that the safety cables are the proper length. Refer to the sections titled "How to use safety cables" and "Proper installation of safety cables" for further information.

- **Check the motorhome turning radius.** Some motorhome chassis have such a tight turning radius that you can damage your motorhome, towed vehicle or tow bar while turning too sharply. Before getting on the road with your towed vehicle, you should test your turning radius in an empty parking lot.

With the towed vehicle attached, have someone watch as you slowly turn sharply to see whether you have this potential problem. If you do, note how far you can safely turn the motorhome's steering wheel and be sure not to turn it further when towing. Damage that results from turning too sharply is not covered by warranty.

- **Never use the tow bar to tow more than one vehicle.** In some states it is legal to have one vehicle towing more than just one vehicle (for example, a truck which is towing a trailer which is towing a boat). However, when using a tow bar, never tow more than one vehicle or non-warranty damage or injury may result.

- **The tow bar stinger fits motorhome hitch receivers with two-inch inner diameters.** If the motorhome hitch receiver is a larger size, attach a two-inch adaptor sleeve (not supplied) to the hitch receiver.

Damage to the tow bar stinger or other components of the tow bar, abnormal wear patterns on the towed vehicle's tires, as well as other, consequential damage may result if an adaptor sleeve is not used.

- **Keep the tow bar clean and well-lubricated.** As is the case with most precision equipment, frequent cleaning and care results in better performance and longevity. Refer to the section titled "Care and cleaning" for further information.

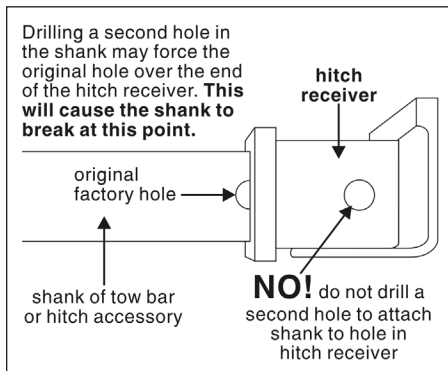

⚠ WARNING

Failure to follow these instructions may cause non-warranty property damage, personal injury or even death.

⚠ WARNING

Towing vibrations will force the linch pins out unless they are properly locked in place. Refer to Figure 1.

Figure 1

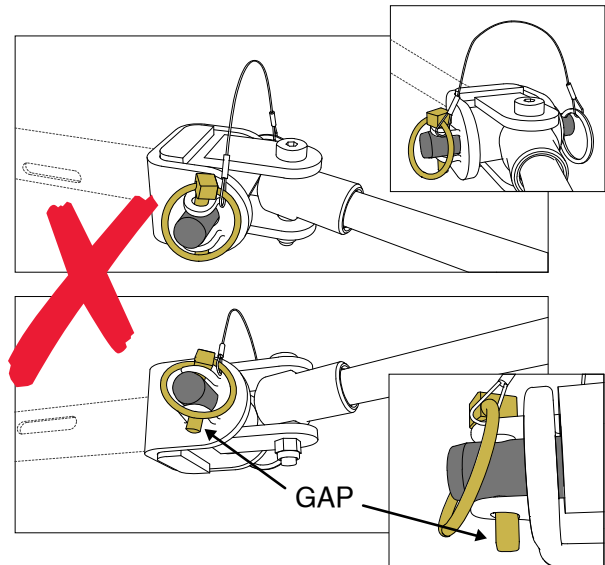

If the ring does not snap against the pin, spin the pin around and flip the ring to the other side.

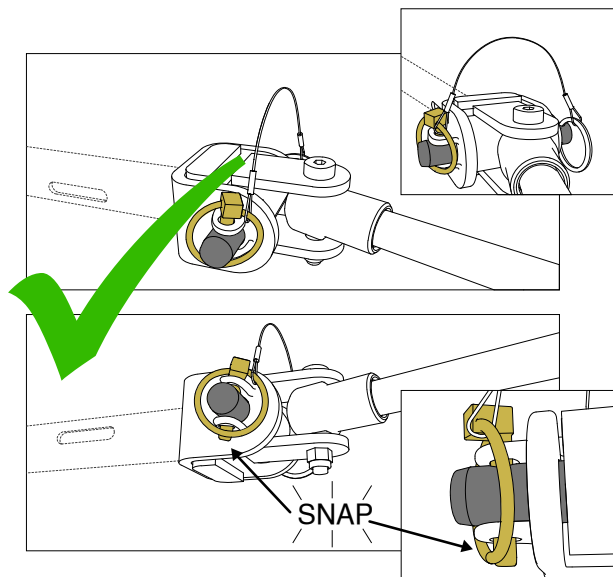

⚠ WARNING

Failure to properly attach and lock all linch pins will result in the loss of the towed vehicle, which may cause property damage, personal injury or even death.

CONNECTING THE TOW BAR

CAUTION

Use caution when handling the tow bar – if your hands, fingers or any part of your body are caught between moving components, they can be pinched, cut or otherwise injured.

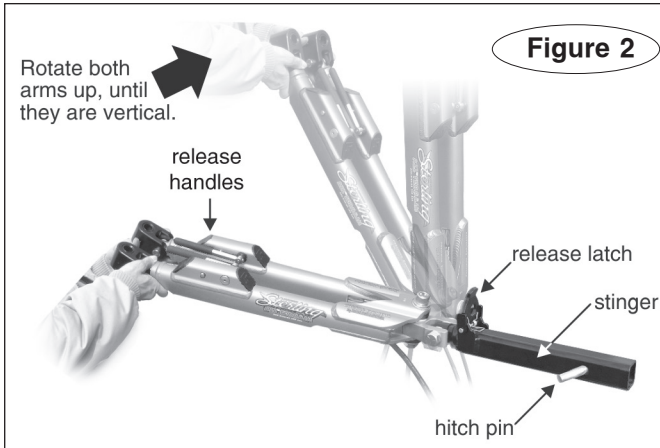

1. Drive the vehicle within three or three-and-a-half feet of the motorhome hitch receiver. The vehicle does not have to be perfectly centered to the hitch receiver, just close. Then, put the vehicle in gear (park), set the emergency brake and chock one of the wheels.

2. With the tow bar in the folded position, insert the stinger into the motorhome hitch receiver and secure it with the hitch pin and clip (Figure 2).

3. Hold both tow bar arms firmly and rotate them up, so that they are vertical, as shown in Figure 2.

CAUTION

Attach the tow bar so that the release handles and the release latch are pointing up. Components of the tow bar may be damaged if the tow bar is attached with the release latch or the release handles pointing down.

WARNING

Never let go of the tow bar when it is in the vertical position. The arms can fall and cause severe personal injury.

4. Push the release latch (Figure 3) forward, to bring both arms down to a horizontal position.

Standing to one side, swing both arms away from you. Then, align the holes in the outermost arm with the holes in one of the tabs on

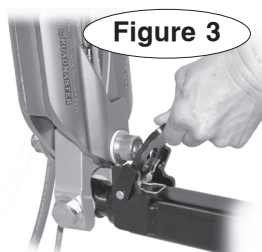

the baseplate (Figure 4 – next page).

Attach the tow bar arm to the baseplate with one of the included base pins (Figure 4). Attach the arm so that the head of the shoulder bolt (Figure 4) is facing up. Lock the base pin with a linch pin (Figure 4) or optional padlock – part number 301 (one padlock) or 302 (two padlocks).

The linch pin must be locked. The ring (Figure 1) is spring-loaded – it must be snapped over the pin, as shown in Figure 1, with the curved side of the linch pin touching the ring, in order to keep the base pin secure.

WARNING

Both tow bar arms must be attached to the baseplate and locked with a linch pin. Towing vibrations will force the linch pins out unless they are properly locked in place over the base pins on both baseplates.

Failure to properly install and lock both base pins will result in the loss of the towed vehicle, which may cause property damage, personal injury or even death.

5. Now, swing the other arm to the opposite side and connect it in the same manner.

6. Attach the safety cables and plug in the power cord (see pages 7 and 8).

Before towing the vehicle, be sure the steering is unlocked, the transmission is in the proper setting and the emergency brake is released. Remove the wheel chock.

Check the owner's manual for the proper towing procedure(s) or requirement(s) for towing.

WARNING

Do not tow the vehicle until the tow bar is attached with all pins or padlocks. Unless the tow bar is secured to both vehicles with all appropriate pins or padlocks, the vehicle will detach, which may cause property damage, personal injury or even death.

7. When you drive away, steer briefly to the left and then to the right, to extend, self-center and lock each tow bar arm.

Always stop at this time. Check the tow bar to ensure that both arms are locked before towing further. Additionally, check the other components of your towing system.

WARNING

Both tow bar arms must be locked before towing. If they are not, the momentum of the towed vehicle will apply excessive force to the tow bar arms and other components of the towing system, which may cause the towing system to fail, resulting in property damage, personal injury or even death.

Connecting the tow bar

continued from preceding page

Figure 4

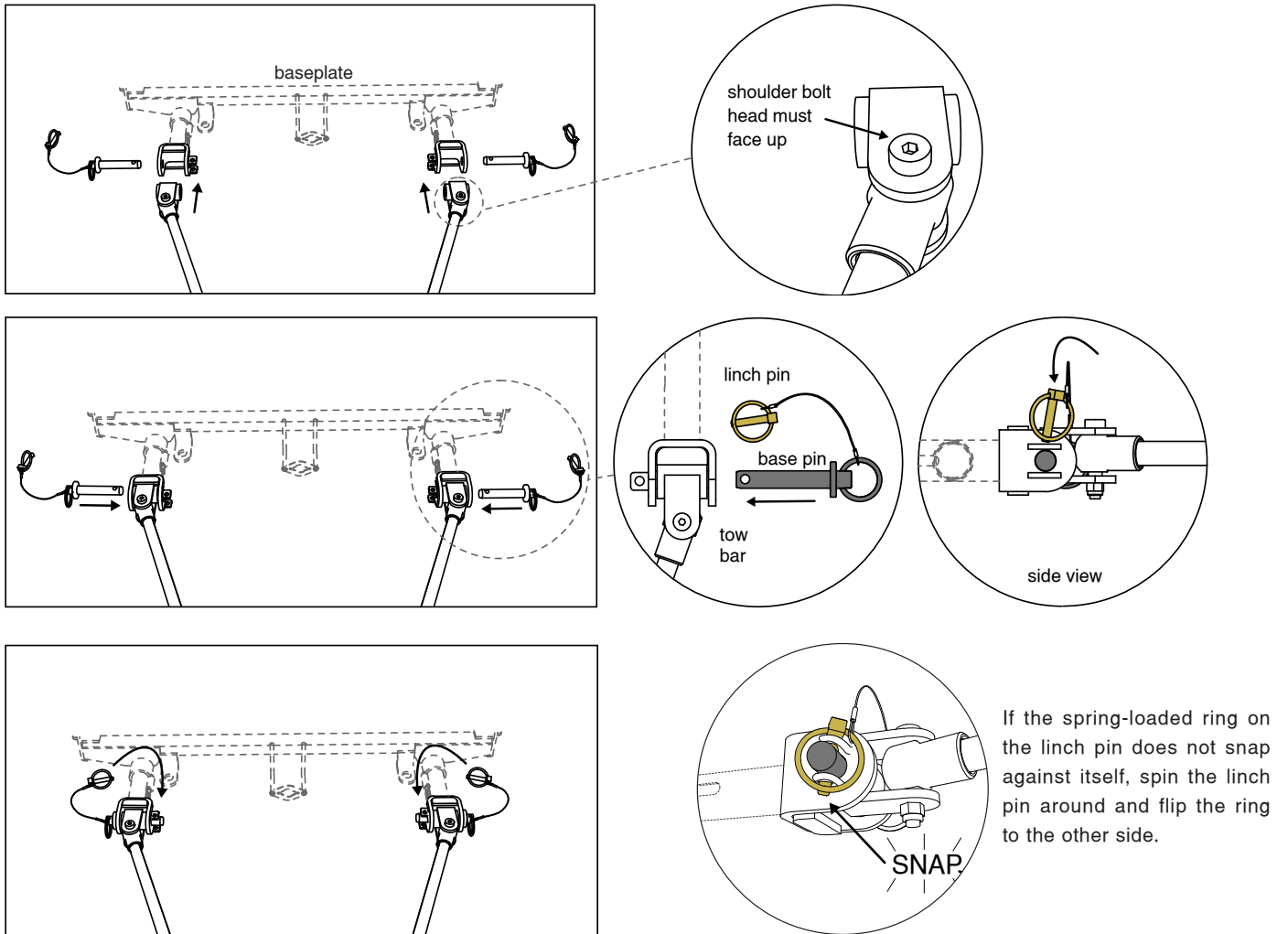

⚠ WARNING

Do not tow if the tow bar is more than three inches out of level. See "Stay in the Safe Zone" on page 9.

Towing out of level creates excessive strain on the tow bar, baseplate and frame, which can cause the towing system to fail, causing property damage, personal injury or even death.

⚠ WARNING

Both tow bar arms must be attached to the baseplate and locked with a linch pin. Towing vibrations will force the linch pins out unless they are properly locked in place over the base pins on both baseplates.

Failure to properly install and lock both base pins will result in the loss of the towed vehicle, which may cause property damage, personal injury or even death.

⚠ WARNING

Do not tow a vehicle using a tow bar baseplate, safety cables or a hitch receiver rated less than the actual weight of the towed vehicle or failure may occur during towing, causing property damage, personal injury or even death.

DISCONNECTING THE TOW BAR

1. Disconnecting the tow bar is essentially the reverse of connecting it. First, always try to park on level ground, with the towed vehicle in line with the motorhome. This will eliminate most of the tension between the vehicles, allowing for an easier disconnect.

2. Disconnect the electrical wiring harness, safety cables and any other towing system accessories.

3. Lift the release handles on each tow bar arm (Figure 5) to release the locking mechanisms.

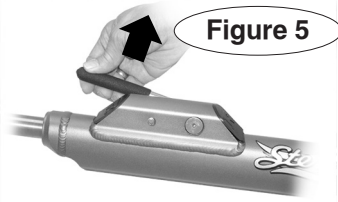

(Usually, one of the handles will require more pressure to release. This is the arm that has the majority of the tension between the two vehicles.)

⚠ WARNING

Always put the towed vehicle in gear (park), set the emergency brake and chock one of the wheels after lifting the release handles, and before removing the base pins. Failure to do so may result in a 'runaway' vehicle or may crush you between the towed vehicle and the motorhome, causing property damage, personal injury or even death.

4. Put the towed vehicle in gear (park), set the emergency brake and chock one of the wheels.

5. Remove the base pins and store the tow bar on the motorhome by reversing the connection procedure (under "Connecting the tow bar").

Note: if you must park on an uphill incline, you may find that you cannot remove the base pins even with the tow bar arms released. The weight of the towed vehicle trying to roll back (Figure 6) is binding the pins in place.

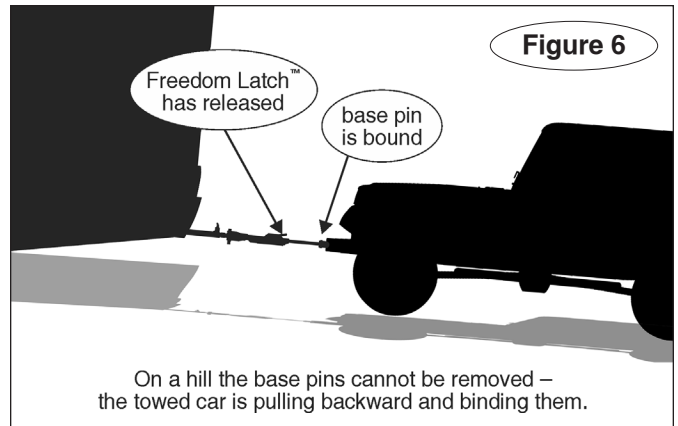

Allow the towed vehicle to idle forward just enough to take the tension of this weight off the pins. Then hold the vehicle in position by first applying the emergency brake, then shifting into park.

Once the tension is off, lift the release handles again and the pins will be removed more easily.

ROADMASTER recommends replacing at least one of the linch pins with a padlock (part number 301, 302 or 308) to prevent accidental release or theft.

CAUTION

The tow bar can be stored on the motorhome with the arms rotated to the left or the right. To avoid the possibility of damage to the bushings, rotate the arms away from the engine exhaust.

The bushings at the end of the tow bar arms can be warped by heat from the exhaust. If the bushings are warped, the tow bar arms will not slide easily, or they may not slide at all – it may be difficult to connect or disconnect the tow bar until the bushings are replaced.

WIRING INSTRUCTIONS

If you should need to rewire the six-wire plug and socket, or wire a seven-way socket, follow the instructions below.

CAUTION

If it's necessary to attach an electrical socket bracket (see below), make certain to attach the bracket close to the center of the towed vehicle. If the bracket is attached too far to either side, the bracket and the electrical socket may be pulled away when the motorhome turns.

WARNING

If the plugs and sockets are not properly wired, the electrical connection will not function, and the towed vehicle's turn signals and brake lights will not mimic those of the motorhome. Drivers behind the towed vehicle will not be alerted by turn signals or brake lights, which may result in a traffic accident, causing property damage, personal injury or even death.

Wiring the plug for a six-wire system

1. Insert the end of the electrical cord through one of the cable guides.
2. Strip ¼" to 3/8" of insulation from the ends. Connect the wires according to Figure 7; apply a silicone sealant to the attachment points to help prevent damage from moisture and corrosion.

Wiring the socket for a six-wire system

1. If necessary, find a suitable location to install one of the electrical socket brackets on the front of the towed vehicle, in reach of the existing six-wire harness. The bracket must be attached close to the center, and to a surface of sufficient strength to hold it firmly in place.
2. Strip ¼" to 3/8" of insulation from the ends of the wires. Loosen the set screw at the back of the socket and push the inner connector out the front. Then run the six-wire electrical cord through the back of the protective boot and the housing.
3. Loosen all of the set screws on the side of the socket, and connect the wires to the back of the socket as shown in Figure 7.
4. Tighten all the set screws and check each wire to ensure that it is fastened securely. Apply a clear silicone sealant around each wire entry and set screw indentation to help weatherproof the socket and secure the set screws.

5. Connect the power cord to the motorhome and towed vehicle. Test the towed vehicle's turn signals, tail lights and brake lights to ensure they operate in conjunction with those of the motorhome.

Wiring the socket for a seven-wire system

If the motorhome does not have an electrical socket or has the wrong socket, install and wire the socket according to Figure 8. A socket bracket (optional) must be installed at the rear of the motorhome, as close to the center as possible, to a surface of sufficient strength to hold it firmly in place.

Figure 8

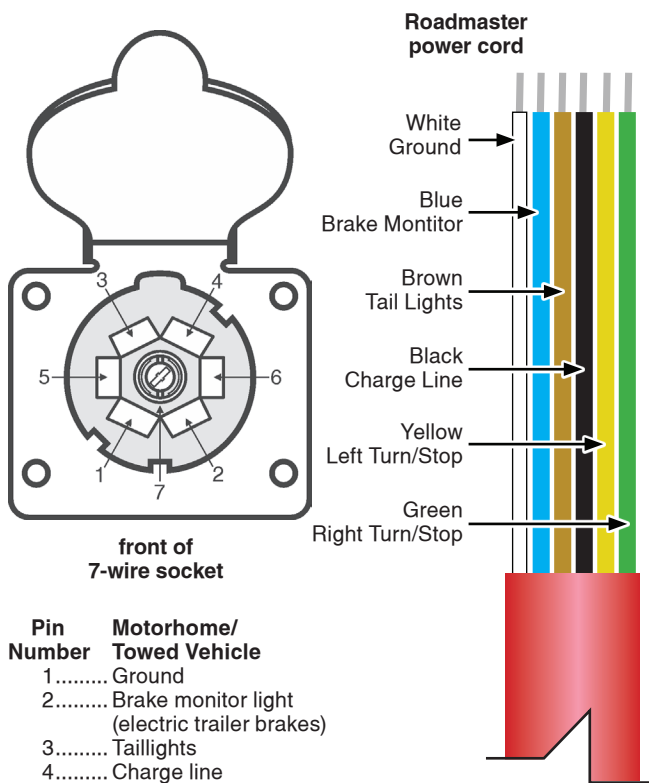

Pin Number	Motorhome/ Towed Vehicle
1	Ground
2	Brake monitor light (electric trailer brakes)
3	Taillights
4	Charge line
5	Left turn/Stop
6	Right turn/Stop
7	Auxiliary/Access

* 'N/A' means this socket is not used in this wiring configuration.

Figure 7

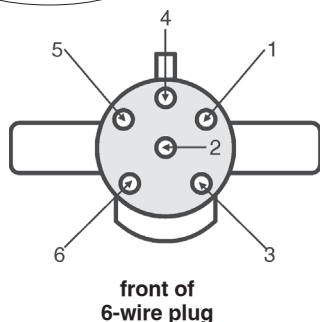

Pin Number	Wire Color	Motorhome/ Towed Vehicle
1	Blue	Brake monitor light (electric trailer brakes)
2	Black	Auxiliary/Charge
3	Green	Right Turn/Stop
4	Brown	Taillights
5	White	Ground
6	Yellow	Left Turn/Stop

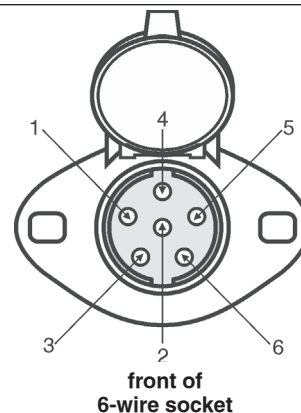

HOW TO USE SAFETY CABLES

Safety cables are an integral part of your towing system. They are a secondary safety device, required by law in many states. This section and the following section will acquaint you with how to use them properly.

- The safety cables must connect the towing vehicle to the towed vehicle, frame to frame.
- The safety cables must be rated at 8,000 pounds weight capacity per pair, or higher. This is the maximum weight capacity of the tow bar – the towed vehicle and all its contents cannot exceed 8,000 pounds.
- Pull the safety cables so that all the slack is at the motorhome. **Make sure there is enough slack in the cables at the motorhome to allow for sharp turns** – if there is not enough slack, the towing system will be severely damaged when the motorhome turns a sharp corner.
- The safety cables must be the correct length...
 - Make sure the cables are not too short – if you use a receiver hitch extension or other equipment that extends the distance between the towed vehicle and the motorhome, the standard cables may be too short. If the cables are too short, the towing system will be severely damaged when the motorhome turns a sharp corner.

(Safety cable extensions in a variety of lengths are available from ROADMASTER.)

- Make sure the cables are not too long – the cables should not hang down to the extent they may catch on obstructions, or drag on the ground. This much slack could cause damage to the towing system, the towed vehicle, or the motorhome.

If the cables are too long, wrap the excess cable around the tow bar to take up the slack. **Make sure there is enough slack in the cables at the motorhome to allow for sharp turns.**

- Damage caused by using safety cables of an incorrect length is not covered under warranty.
- Always cross the cables under the hitch receiver, as shown in Figure 9 under “Proper installation of safety cables.” . In the unlikely event the tow bar separates from the motorhome, crossing the cables will help prevent the tow bar from dragging on the ground, which can cause the tow bar to “pole vault” the towed vehicle.

PROPER INSTALLATION OF SAFETY CABLES

Cross the safety cables under the hitch receiver, as shown in Figure 9.

Option 1

If the tow bar baseplate is similar to the one shown in Figure 9 and the safety cables are long enough, connect the snap hook to the safety cable anchor built into the baseplate.

Option 2

If the tow bar baseplate has removable arms and your safety cables are not long enough to bypass them, then connect as shown in Figure 10 using short safety cables (sold separately).

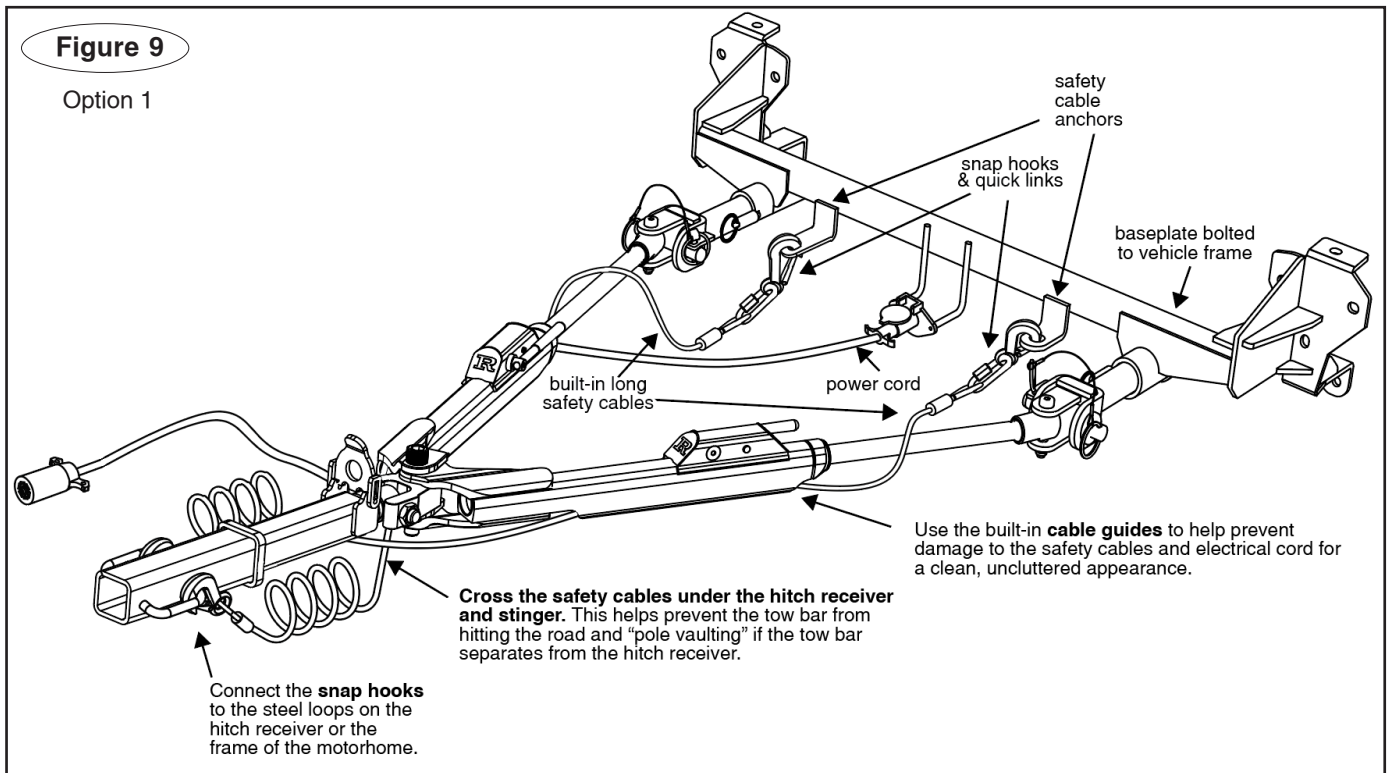
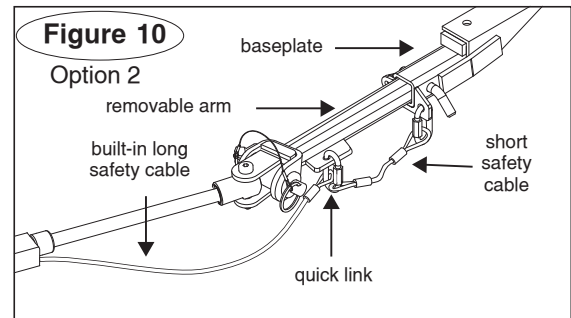

⚠ WARNING

The safety cables must be carefully routed so that they cannot become pinched, frayed, scraped or otherwise damaged, and so they will not drag when going over dips or low spots. Do not use the cables if they show any signs of wear or damage – immediately discontinue towing and replace the cables.

Failure to follow these instructions will result in cable failure, which may cause property damage, personal injury or even death.

⚠ WARNING

If the quick links are not completely tightened, with the loop closed, the safety cables may detach. In the event of a towing system failure, the towed vehicle will detach, which may cause property damage, personal injury or even death.

STAY WITHIN THE 'SAFE ZONE'

Towing with a motorhome-mounted tow bar which has an upward or downward slope puts undue strain on the entire towing system. For that reason, **do not tow if the tow bar is not within the 'Safe Zone' – no more than three inches above or below level.**

Towing a vehicle with a tow bar that is not within the Safe Zone will result in significant wear and tear on the tow bar and baseplate, significant wear and tear on the vehicle's suspension and frame, and the eventual failure of the towing system.

To determine if the tow bar is within the Safe Zone – first, connect the motorhome and towed vehicle on level ground. Next, measure the distance from the center of the motorhome receiver down to the ground. Then, measure the distance from the center of one of the base pins down to the ground.

Compare these two measurements. To be within the Safe Zone, they cannot be more than three inches apart if the base pin is above or below the motorhome hitch receiver. See Figure 11.

If the tow bar is not within the Safe Zone, you must purchase a hitch accessory to raise or lower the hitch receiver. ROADMASTER has accessories available – Hi-Low Hitches and Dual Hitch Receivers – which will raise or lower the hitch receiver from two to 10 inches, depending on the model.

Towing with the tow bar more than three inches above or below level will void the ROADMASTER warranty.

⚠ WARNING

Failure to follow these instructions may cause property damage, personal injury or even death.

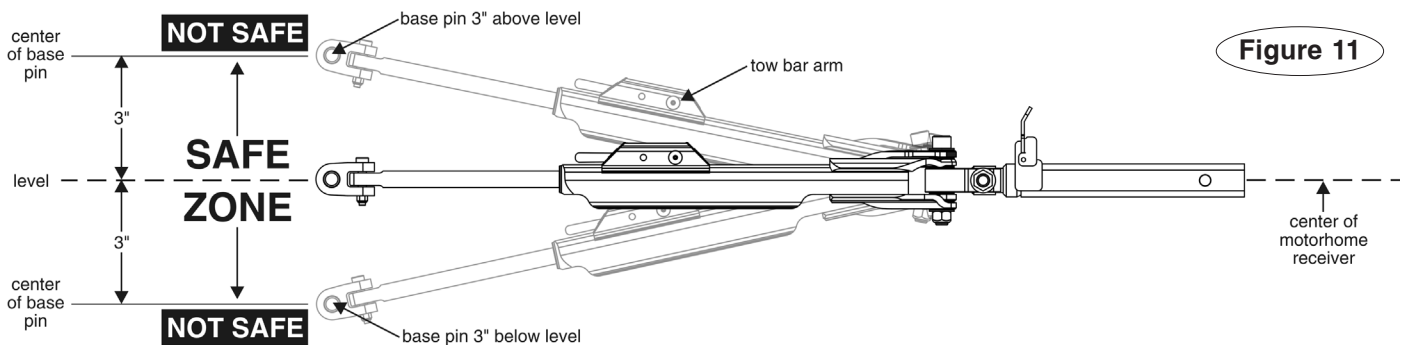

CARE AND CLEANING

As is the case with most precision equipment, frequent cleaning and care results in better performance and longevity. Use the following guidelines to keep the tow bar arms clean and well-lubricated.

Always clean the tow bar arms before lubricating. Use a water-soluble cleaner such as ROADMASTER Tow Bar Cleaner (part number 9932) – it does an exceptional job of breaking down road film, dirt and grease.

To clean one of the tow bar arms, extend the arm and liberally apply cleaner to the inner arm (Figure 12).

Work the arm in and out to flush out dirt from the inside of the assembly. Wipe the dirt off and repeat until the arm is clean.

Repeat for the other arm.

CAUTION

Do not use petroleum-based products to clean or lubricate the tow bar. Petroleum will attract dirt and dust, which will impede the operation of the sliding arms and/or other components. Certain petroleum products may also corrode non-metallic components.

Damage caused by using a petroleum-based product to clean or lubricate the tow bar is not covered under warranty.

After cleaning the tow bar, wipe any remaining cleaner away.

Now that you have a clean, dry tow bar, use a dry silicone lubricant, such as LubeMaster (part number 747),

to lubricate the tow bar – spray a liberal amount of the silicone into all moving parts. Flex the tow bar components, to work the lubricant in. LubeMaster sprays on wet, then dries in seconds, so it won't attract dirt or debris.

(Using a silicone lubricant on the base pins will make them easier to pull out, and also creates an oxygen barrier which helps prevent corrosion.)

CAUTION

Always clean the tow bar arms, as described above, before lubricating them. Silicone coats and covers in a thin layer. If it is not removed, it will reduce the clearance, preventing proper operation.

Extended storage –

before storing your tow bar for an extended period of time, be sure to clean and lubricate it as above. Store the tow bar in its cover (optional, part number 055-3), to protect it from the elements.

Note: to remove scratches and restore luster on the inner arms, we suggest that you use extra fine (0000) steel wool, 3M "Scotch Brite" (fine pad) or a similar product.



STERLING ALL TERRAIN COMPONENTS

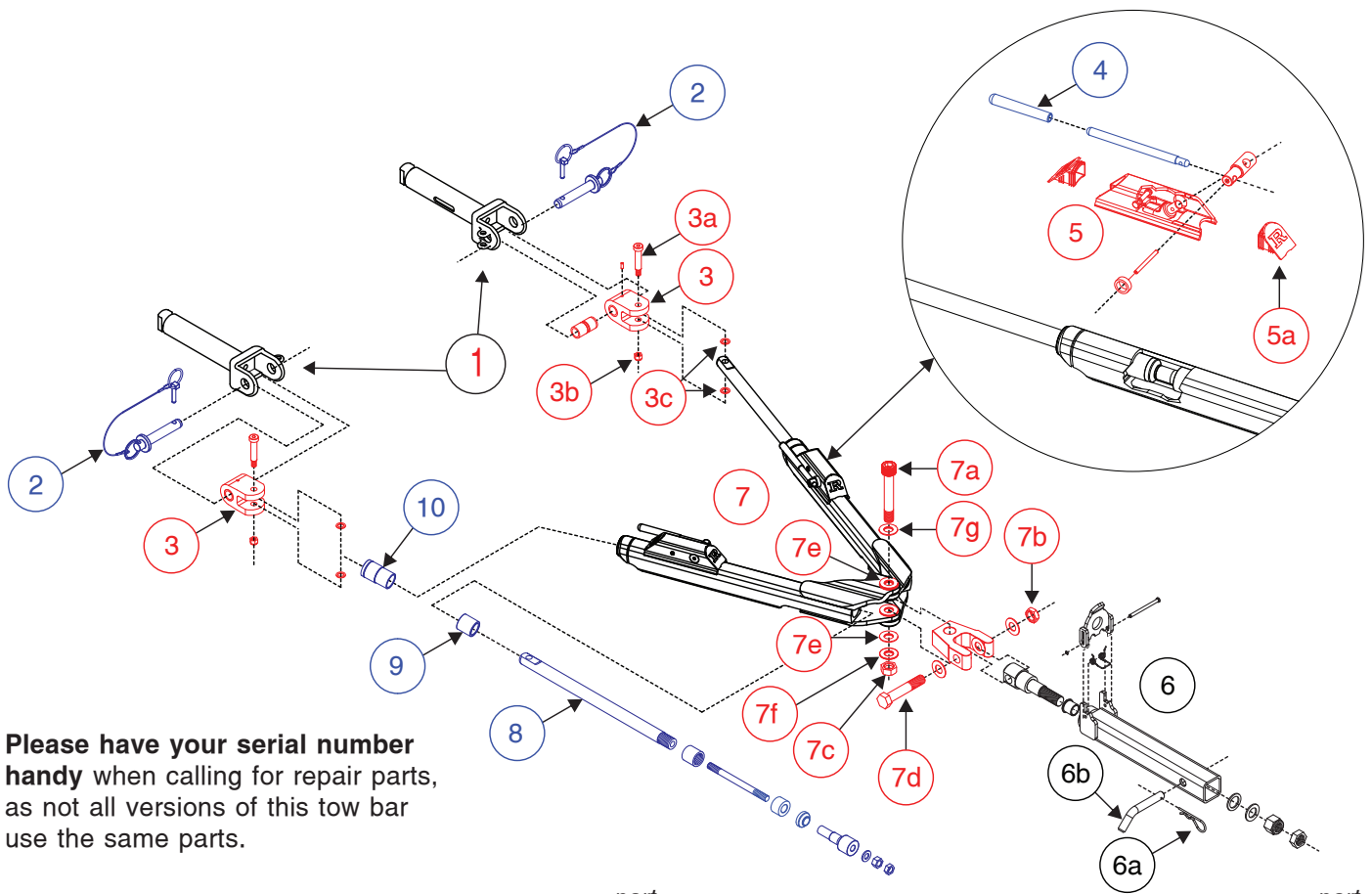

Please have your serial number handy when calling for repair parts, as not all versions of this tow bar use the same parts.

description	part number
1 baseplate arms (not included)	
2 base pin, cable and linch pin (two each; color-coded blue)	910029
3 swivel ear assembly, one each – includes part numbers 5a, 5b and 5c (color-coded red).....	910661
3a ½" x 2" screw.....	350376-00
3b nylon lock nut.....	350255-00
3c ½" nylon washer	350356-00
4 Freedom Latch lock handle and rubber grip (color-coded blue)	750600
5 Freedom Latch spring replacement kit with latch caps – contains four latch caps (part number 5a), and two springs and two snap rings (not shown) – color-coded red.....	910652
5a latch cap only.....	200460-00
6 stinger assembly, complete (color-coded black; part numbers 6a and 6b sold separately)	910520
6a hitch pin clip (two).....	910028
6b hitch pin and clip (one each)	910027
7 yoke assembly with bushing (color-coded red; part numbers 7a through 9e sold separately)	910575
7a Qty1.....¾" x 4¾" bolt.....	350190-20
7b Qty 1.....¾" jam nut.....	350264-10
7c Qty 1.....¾" lock nut	350738-00
7d Qty 1.....¾" x 4 1/8" bolt	350191-00
7e Qty 13*.....¾" acetal washer	350358-00
7f Qty 3.....¾" flat washer	350314-60
7g Qty 1.....¾" yellow zinc washer.....	350314-40

* not all washers shown in the drawing

description	part number
8 inner arm assembly, driver's and passenger side (color-coded blue)	910660-10
9 Nylatron inner arm spacer (color-coded blue) ...A005406 (replaces obsolete three-part bushing kit 200680-00 (qty 1) and 654303 (qty 2))	A005406
10 snap-in bushing (color-coded blue).....	A004608

NOT SHOWN

- safety cable:
 - pair
 - each
- red power cord
 - 7-to-6 wire straight power cord with bracket.....
 - 7-to-6 wire straight power cord only
- 6-wire plug only
- 6-wire socket only
- 7-wire plug only
- quick links - 2 pack.....
- snap hooks for safety cables.....

AVAILABLE OPTIONAL EQUIPMENT

- red-handled large base pins - pair
- (an upgrade for 910029)

