

INVISI BRAKE®

New Car Kit

part number 98700

Installation Instructions



Time Tested • Time Proven

ROADMASTER, Inc. • 6110 NE 127th Ave. • Vancouver, WA 98682

• 800-669-9690 • Fax 360-735-9300

© 2011-2021 ROADMASTER, Inc. All rights reserved.

854828-25 11.21

roadmasterinc.com

roadmasterinc.com/patents

InvisiBrake specifications

| | |
|---------------------------------------|---------------------------------|
| Controller height..... | 2¾ inches |
| Controller width..... | 8¾ inches |
| Controller length..... | 8¾ inches |
| Voltage..... | 12 volts DC |
| Fuse size..... | 20 amp |
| Operating temperature range | |
| | -2° to +150° F (-19° to +66° C) |
| Maximum amperage draw..... | 10.8 amps |
| Idle amperage draw..... | 6 mA |
| Battery recharging rate..... | up to 2 amps |
| Approximate maximum air pressure..... | 80 psi |

Required tools

- drill with ½" bit (The drill and bit are only necessary if there is no pre-existing hole through the firewall.)
- test light
- multi-meter
- wire strippers or crimpers
- 7/16", 1/2" and 9/16" wrenches
- 5/32" Allen wrench
- adjustable wrench
- 5/16" and 3/8" drivers

If you are a professional installer...

...return these instructions to the owner, for the owner's future reference.

Table of contents

| | |
|--|-------|
| Kit components..... | 1 |
| To switch the controller between two vehicles..... | 1 |
| Wiring diagram..... | 2 |
| Verify the application..... | 3 |
| General warnings and cautions..... | 4 |
| Remove the controller, cable and air cylinder..... | 4 |
| Installation instructions..... | 5-16 |
| Plan the installation..... | 5-8 |
| Begin the installation – | |
| Attach the clamp, pulley and bracket..... | 9-10 |
| Adjust the cable..... | 10 |
| Route the cable housing | |
| and attach the air line..... | 10 |
| Attach the vacuum line..... | 11 |
| Check the existing wiring..... | 12 |
| Install the break away system; | |
| attach the power and ground wires..... | 12 |
| Attach the four-wire flat harness; | |
| attach the controller..... | 13 |
| Install the monitor system..... | 14 |
| Test the system..... | 15-16 |

WARNING

These instructions pertain to the initial installation of the new car kit components only. Operating instructions are contained in the owner's manual; installation instructions for the complete system are available at www.road-masterinc.com.



Read all instructions before installing or operating InvisiBrake. Failure to understand how to install or operate InvisiBrake could result in property damage, personal injury or even death.

IMPORTANT NOTICE!

Safety Definitions

These instructions contain information that is very important to know and understand. This information is provided for **safety** and to **prevent equipment problems**. To help recognize this information, observe the following symbols:

WARNING

WARNING indicates a potentially hazardous situation which, if not avoided, could result in property damage, serious personal injury or even death.

CAUTION

CAUTION indicates a potentially hazardous situation which, if not avoided, may result in property damage, or minor or moderate personal injury.

CAUTION

CAUTION used without the safety alert symbol indicates a potentially hazardous situation which, if not avoided, may result in property damage.

NOTE

Refers to important information and is placed in italic type. It is recommended that you take special notice of these items.

Major components

| part number | description |
|-------------|--|
| 1 | 452104-10.....pulley |
| 2 | 452140.....cable anchor bracket |
| 3 | 945202-00brake pedal clamp (with mounting nuts and bolts) |
| 4 | 450008-15car side monitor wire, 15 feet long (not shown) |
| 5 | 945203-00.....four-wire harness: break away, power and ground |
| 6 | 650898break away switch and pin 200200-20.....break away pin only |
| 7 | Vacuum check valves 4521413/8" vacuum check valve 452142.....1/2" vacuum check valve |
| 8 | 450701.....1/8" air line (not shown) |
| 9 | 4507001/4" nylon vacuum line (not shown) |
| 10 | 4521111/4" rubber vacuum hose, one foot (not shown) |
| 11 | 452137.....3/8" rubber vacuum hose (not shown) |
| 12 | 452136.....1/2" rubber vacuum hose (not shown) |
| 13 | 4521183/8" vacuum line tee |
| 14 | 4521161/2" vacuum line tee |
| 15 | 945204-00four-wire flat harness: towed lighting |
| 16 | 650900-20.....break away harness, 20 feet (not shown) |

(Components not shown to scale)

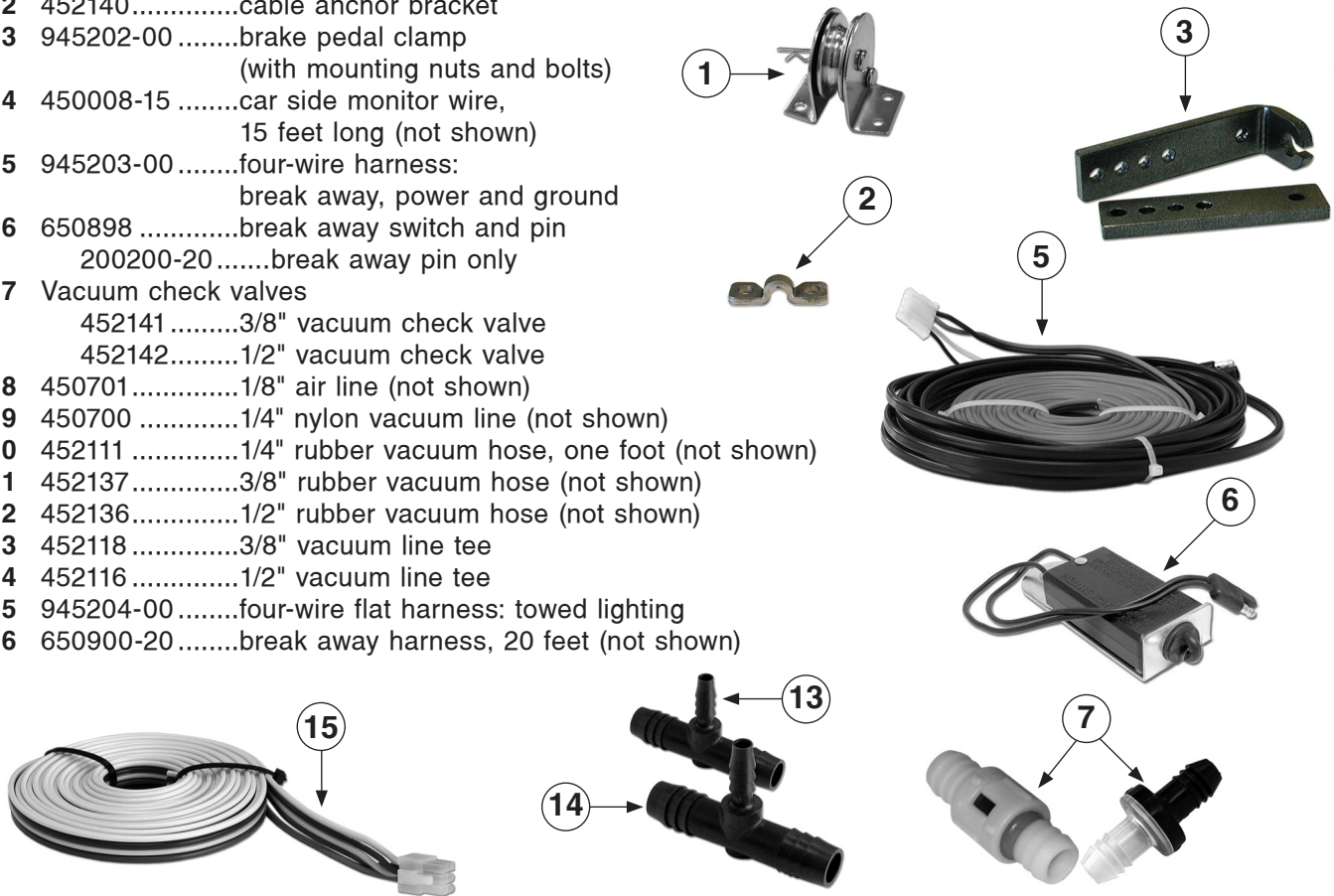

Hardware

| Qty. | Part number | Description | Qty. | Part number | Description |
|------|-------------|--------------------------------|------|-------------|--|
| 5 | 300101-00 | yellow butt connector | 3 | 357250-00 | 1/4-14 x 3/4 self-tapping screw, 8 pt. |
| 6 | 350247-30 | 10-16 x 1/2 self-tapping screw | 1 | 452134 | cushioned clamp |
| 1 | 350400-20 | 1/4" x 1 bolt | 2 | 450707 | sliding clamp |
| 1 | 350251-20 | 1/4" nut | 2 | 350390-75 | 10-24 Allen head bolt |
| 1 | 350318-00 | 1/2 x 3/8 rubber grommet | 2 | 350249-00 | 10-24 lock nut |

To switch the controller between two vehicles...

This kit is designed to permanently transfer the InvisiBrake supplemental braking system from one vehicle to another.

However, it may also be used to add the InvisiBrake system to a new vehicle, while retaining it in the original. If this is your intent, additional components will be necessary in order to switch the InvisiBrake controller between the two vehicles:

- 452143 – 1/4" check valve

This check valve will allow you to remove the controller without creating a vacuum leak in the vehicle's power brake system.

- 452109-20 – the InvisiBrake air cylinder
- 452109 – the InvisiBrake cable assembly

The above components will allow you to quickly and safely tow two vehicles using the same InvisiBrake controller.

Refer to the original instructions for proper installation. (The most current version of these instructions is available at www.roadmasterinc.com, under 'Support'.)

front of towed vehicle

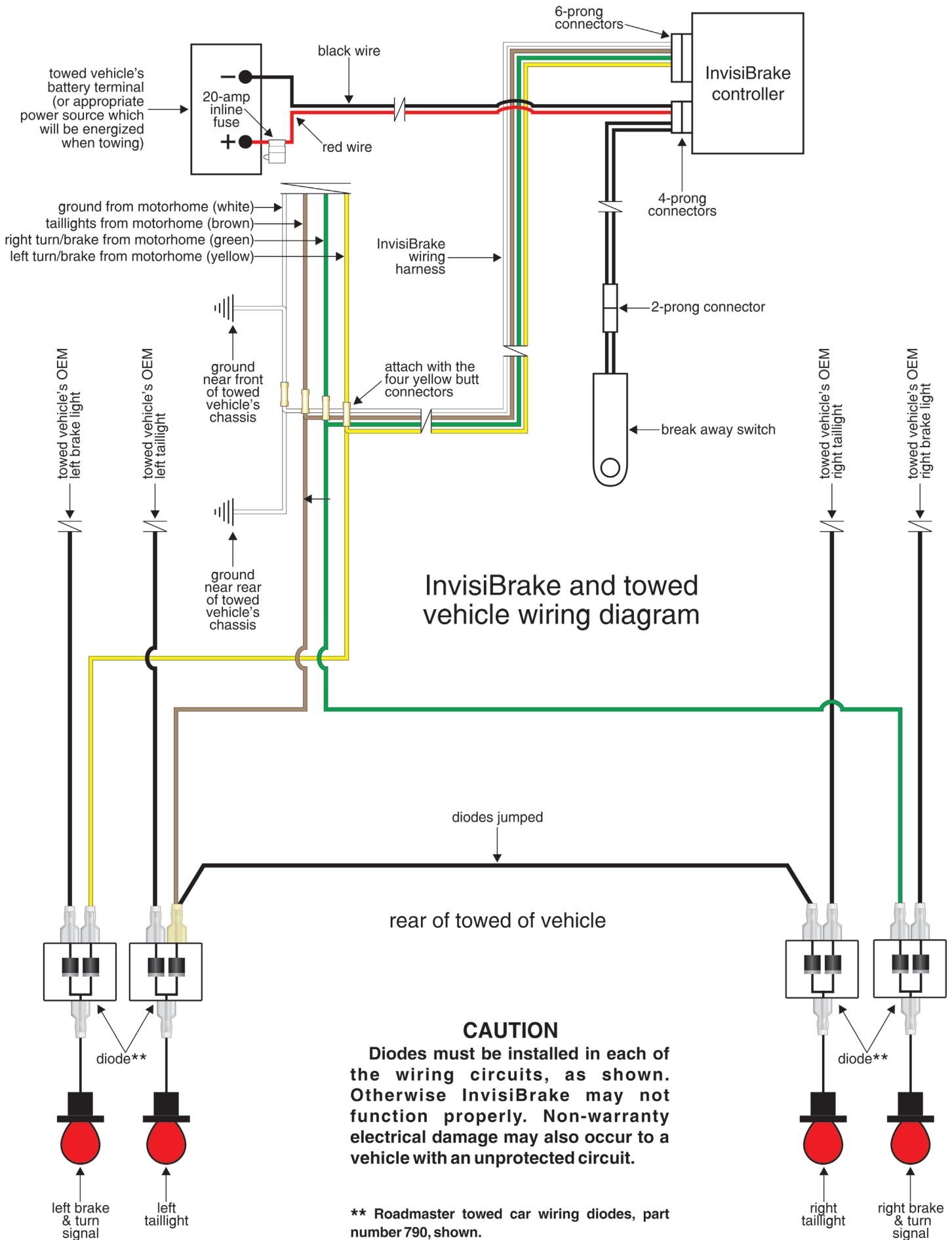

IMPORTANT!

Read this before you continue.

InvisiBrake will not work in all vehicles. Verify the application before continuing.

1. Refer to the InvisiBrake application resource guide under 'Vehicle-Specific Information' at www.roadmasterinc.com. (If you are a professional installer, consult this list often – it is updated constantly.)

2. Determine which type of braking system is in the towed vehicle...

- If the vehicle has a power brake booster and vacuum line similar to that shown in Figure 14, it has vacuum-assisted power brakes. Proceed to step 3, "Check the lighting system."

- If the vehicle does not have vacuum-assisted power brakes, it likely has hydroboost power brakes. If they are *electric* hydroboost, InvisiBrake will work. If they are *standard* hydroboost, it will not work.

To determine if hydroboost brakes are electric or standard – make all adjustments necessary to prepare the vehicle for towing, as per the owner's manual. These adjustments may include disconnecting the battery or pulling fuses.

Make certain that the ignition is in the "tow" position. Turn off the heater, radio and any other accessories that could make noise. Have an assistant pump the brakes several times while you listen carefully under the hood. If you hear an electric pump running, the vehicle has electric hydroboost.

Note: the electric pump motors are very quiet. Perform the test in an area without background noise.

If you don't hear a pump running, either the vehicle has standard hydroboost or the power brake pump is not energized when the vehicle is in the "tow" mode. In either case, InvisiBrake will not function.

ROADMASTER's other braking systems, such as Even Brake, BrakeMaster and the 9700 will work in vehicles whose power brakes are not energized when the vehicle is in the "tow" mode.

3. Check the lighting system...

- If the vehicle has a 'bulb and socket' lighting system, magnetic lights or a light bar, it must be grounded directly to the chassis, or InvisiBrake will not function.

Note: usually, these devices are only grounded to the RV chassis. They must be grounded to the towed vehicle's chassis in order for InvisiBrake to function.

CAUTION

Refer to the owner's manual before attaching a ground wire. Some manufacturers stipulate that ground wires must be attached at specific locations. Significant damage to the vehicle's electri-

cal system, as well as other consequential, non-warranty damage will occur if the ground wire is not attached at one of these points.

4. Verify proper use of diodes...

- If the vehicle has been 'hard-wired' for towing, make certain that diodes are installed to protect both the towed lighting harness and the vehicle's electrical circuits, as shown on page two. **Diodes must be installed to prevent backfeed to the towed lighting harness or InvisiBrake will not function properly.**

- Likewise, if a 'plug and play' electrical harness has been used, diodes must be installed to protect the towed lighting harness. (Most harnesses of this type only have diodes to protect the towed vehicle's electrical circuits.)

CAUTION

InvisiBrake uses the towed lighting harness as a power source. If diodes are not installed to protect this circuit InvisiBrake will not function properly.

- If the diodes are single terminal (as shown below), ROADMASTER recommends replacing them with 'two terminal in, one terminal out' diodes (as shown below).

CAUTION

Although not recommended, if single terminal diodes are used they must be installed in each of the wiring circuits. Otherwise, InvisiBrake may not function properly. Non-warranty electrical damage may also occur to a vehicle with an unprotected circuit.

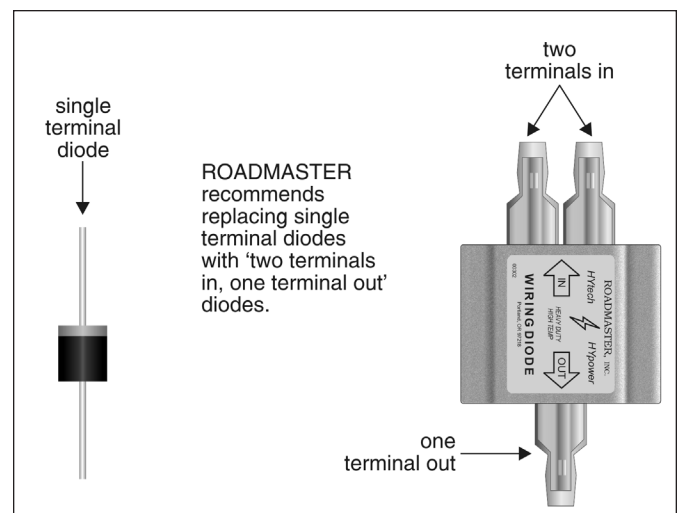

General warnings and cautions

1. This kit consists of the towed vehicle components only. The motorhome components of the InvisiBrake system must be installed and operating correctly for InvisiBrake to function.

2. The controller, pulley, cable anchor bracket, cable housing clamps and the air cylinder are attached with self-tapping screws. Before attaching these parts, make certain that the screws will not damage any components or electronics on the other side.

CAUTION

Failure to follow these instructions may cause non-warranty damage to the vehicle.

3. Route all wiring to avoid the possibility of a short circuit or other damage to the vehicle.

WARNING

Route all wiring to avoid moving parts, sharp edges, the fuel lines or hot components such as the engine or exhaust system.

Use the included wire ties to secure the wiring out of the way.

Wiring exposed by moving parts, sharp edges or hot components may cause a short circuit, which

can result in damage to the vehicle's electrical system as well as other, consequential damage.

Wiring which is attached in close proximity to the fuel lines may ignite the fuel.

Failure to follow these instructions may cause property damage, personal injury or even death.

WARNING

All parts in the interior of the vehicle must be attached so that they will not present an obstruction or hazard to the driver of the vehicle or interfere with the operation of the vehicle.

Failure to follow these instructions may cause a loss of vehicular control, resulting in property damage, personal injury or even death.

WARNING

If a charge line kit is installed in the towed vehicle, apply a silicone sealant to the socket terminals where the wires are connected. Otherwise, stray voltage may energize the turn signal wiring. This will cause inadvertent activation of the supplemental braking system. Severe brake system damage, loss of vehicular control and other consequential damage may occur.

Remove the controller, cable and air cylinder

1. Remove the controller, air cylinder and cable (Figure 1) from the original towed vehicle.

Note: in addition to these parts, the only other component which must be retained (except those in the motorhome) is the monitor wire patch cord (Figure 1).

This cord is not permanently installed — it is connected between the two vehicles during towing.

2. Verify that the 1/4" InvisiBrake vacuum line is attached to the original towed vehicle's vacuum line. Refer to Figure 14.

Note: the 1/4" vacuum line will not be present if the vehicle has full-time ("active") power brakes.

3. If the 1/4" InvisiBrake vacuum line is attached, disconnect it from the vehicle's vacuum line. You **must** either: 1) reconnect the vacuum line with two barbed fittings and a length of tubing, both of the appropriate size (not included); or 2) replace the vehicle's vacuum line with a new one. Do not drive the vehicle until the vacuum line is reconnected or replaced.

WARNING

The power brake vacuum assist will not operate until the vacuum line is reconnected or replaced. Considerable force will be required to apply the brakes and braking distance will be subsequently lengthened, which may cause property damage, personal injury or even death.



Plan the installation

Note: if a Universal Braking Monitor (part number 9530) will be installed, check the InvisiBrake serial number. If it's less than 21603, you must install an optional adaptor, part number 8700-9530.

Note: the mounting locations of the controller, pulley and air cylinder are dependent on each other — where you chose to attach one affects the mounting locations of the other two. Before attaching any of these components, plan where they will all be attached, by following the steps below.

Note: some newer vehicles may require additional equipment. Check the ROADMASTER web site — www.roadmasterinc.com — for vehicle-specific information. Select 'Vehicle-Specific Info,' enter the vehicle make, model and year, then select 'Braking Systems.'

Choose a mounting location for the controller

The ideal location for the controller (page one) is under the driver's or passenger's seat. However, it can be mounted anywhere in the interior of the vehicle — under the rear seats, in the trunk or behind panels.

The controller can be mounted horizontally, vertically or upside down.

Choose a mounting location that meets the following conditions —

- The brake pressure adjustment knob (page one) must be accessible to the installer.

- If you mount the controller under one of the seats, test to make certain that the controller will not interfere with the movement of the seat or affect any adjustments to the seat.

CAUTION

Check seat movement and adjustments

If the InvisiBrake controller is installed under one of the seats, carefully check to make certain that the controller will not interfere with the movement of the seat or affect any adjustments to the seat. Severe non-warranty damage to the seat and/or the controller can result if the seat comes into contact with the controller.

If there is interference, make certain that the seat is not moved beyond the point that would cause damage.

Failure to follow these instructions may cause property damage.

- The controller will be attached with two of the 3/8" self-tapping screws. The underlying material must be of sufficient strength to hold the controller in place; make certain that the screws will not damage any components or electronics on the other side of the firewall.

- An electrical harness will be routed from the con-

continued on next page

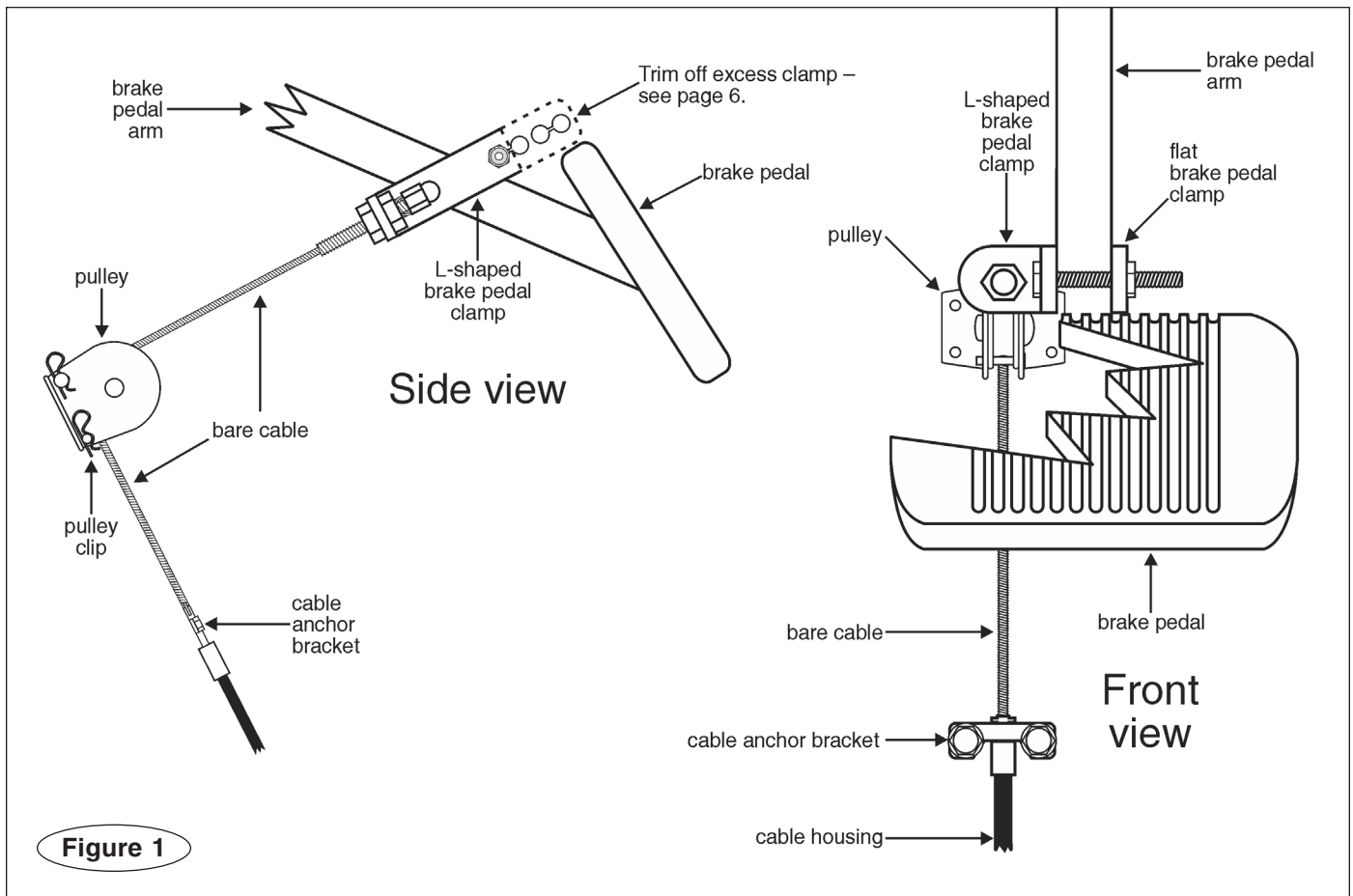

Figure 1

Choose a mounting location for the pulley and brake pedal clamp

continued from preceding page

troller to the vehicle's battery (or if the battery is inaccessible, to an appropriate power source which will be energized when towing). Since the harness is 15 feet long, the mounting location should be within 15 feet of the battery (or power source).

Position the controller at the mounting location you have chosen, but **do not attach it** – it will be easier to connect the wiring, air line and vacuum line with the controller loose.

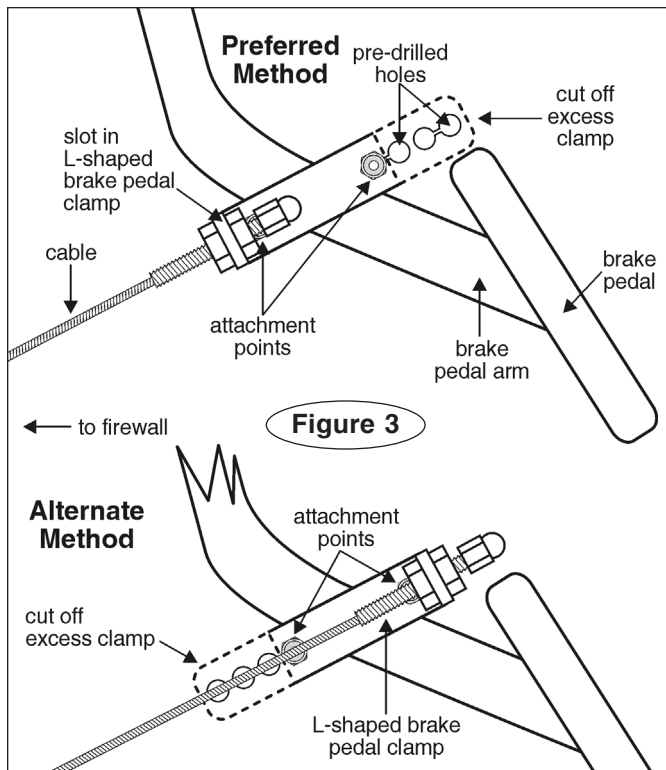
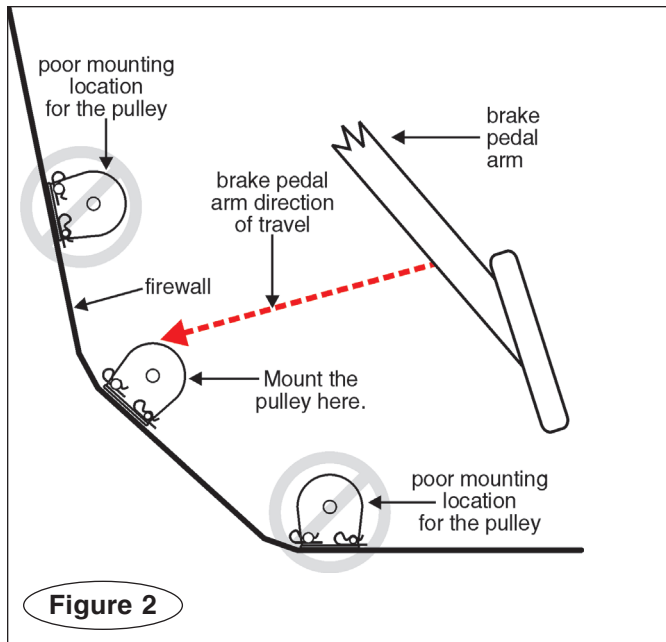

Choose a mounting location for the pulley and brake pedal clamp

Position the pulley and both sections of the brake pedal clamp as shown in Figure 1, so that they are directly in line with each other.

1. Position the pulley in line with the brake pedal arm's direction of travel – see Figure 2.

2. If possible, always install the brake pedal clamp as shown in 'Preferred Method' in Figure 3, with the slot in the L-shaped clamp toward the driver's side door, and with the bend in the L-shaped brake pedal clamp closest to the firewall.

If there are obstructions or other constraints which prevent this, the two sections of the brake pedal clamp can be attached in the following ways...

- With the slot in the L-shaped clamp (Figure 3) on either side of the brake pedal arm.
- With the slot rotated toward the firewall or away from it (Figure 3).

Additionally, you can further adjust the position of the clamp by using different attachment holes:

- The clamp is attached with bolts through two of the five pre-drilled holes (Figure 3). You can move the clamp forward or backward on the brake pedal arm by using different attachment holes.

Additionally, you can trim a portion of the clamp:

- If more clearance is necessary, you can trim a portion of the clamp, once you have decided which two of the pre-drilled holes you will use to attach the clamp.

Note: InvisiBrake will operate most efficiently with the clamp as low as possible on the brake pedal arm. This will generate maximum leverage when InvisiBrake is activated. Therefore, position the clamp as far down the brake pedal arm as possible, without interfering with the normal operation of the vehicle.

⚠ WARNING

Always mount the pulley in line with the brake pedal's direction of travel, and always mount the brake pedal clamp as low as possible on the brake pedal arm. Otherwise, there will not be enough leverage for InvisiBrake to apply the brakes properly.

This will negate the benefits of the supplemental braking system.

Failure to follow these instructions may cause property damage, personal injury or even death.

⚠ WARNING

Make certain that no part of the clamp interferes with the full and complete movement of the brake pedal arm, as shown to the right. Property damage, personal

continued next page

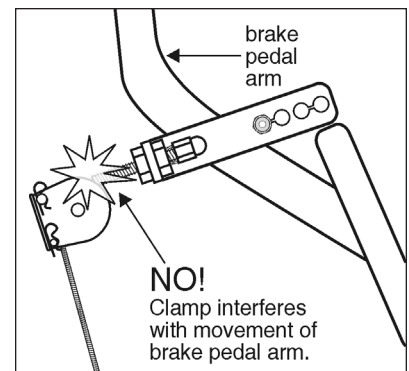

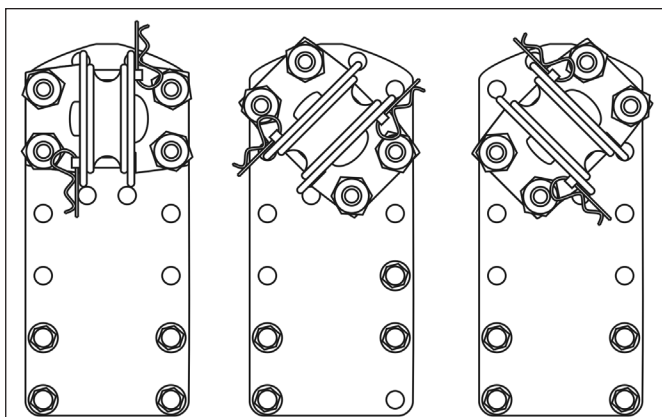
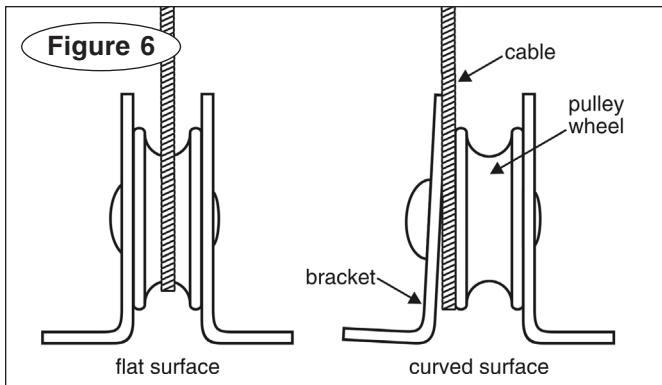
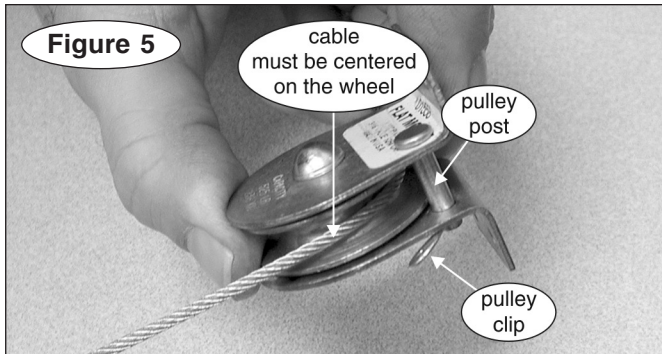
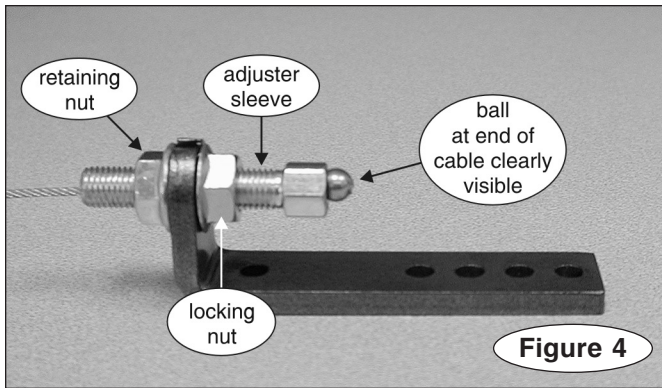

- Optional pulley mounting bracket (part number 8700-PBC)
- The pulley can be rotated in three different ways, as shown above.
 - Use any of the eight mounting holes, based on the application.
 - The bracket can be bent to fit around obstructions, as shown below.

Figure 7

Plan the installation

continued from preceding page

injury or even death may occur if the brake pedal cannot be operated at its full range.

! WARNING

If the vehicle is equipped with brake pedal presets, install the cable and brake pedal clamp assembly with the brake pedal as close to the driver's seat as possible. Make certain that the brake pedal is at that position when towing.

As an option, the brake pedal may be moved to the desired position and disabled. Do not rely on a mental note to never move the brake pedal.

Failure to follow these instructions may cause unintended braking and eventual brake failure, which may result in property damage, personal injury or even death.

3. Look for a mounting location for the pulley on the firewall that meets the following conditions:

- The pulley (Figure 1) must be positioned directly in line with the L-shaped brake pedal clamp so that the cable aligns directly to the center of the pulley wheel (Figure 5).

! WARNING

If the cable is not directly in line to the center of the pulley wheel it may be pulled off the wheel at any time while the vehicle is being driven or while it is being towed. This will lock the brakes.

If the vehicle is being towed this will result in non-warranty damage to the brakes and tires, as well as other consequential damage. If the vehicle is being driven a loss of vehicular control and/or a collision may occur.

Failure to align the cable directly to the center of the pulley wheel may cause property damage, personal injury or even death.

Note: if you switch the L-shaped clamp from one side to the other, it may be necessary to adjust the position of the pulley slightly to the left or right to compensate for the width of the brake pedal arm.

Note: ideally, the pulley should be attached so that the cable runs parallel to the brake pedal arm, as shown in Figure 1. If the design of the passenger compartment or other constraints prohibit this, the pulley can also be mounted at an angle.

However it is mounted, the cable must be directly in line with the center of the pulley, as shown in Figure 5.

- Do not double-wrap the cable

around the pulley for any reason. If the cable is double-



continued on next page

Plan the installation

continued from preceding page

wrapped around the pulley, it may 'jump the tracks' when the vehicle is being driven, as shown above, which will lock the brakes.

WARNING

Do not double-wrap the cable around the pulley. Otherwise, the cable may wrap around the pulley while the vehicle is being driven. This will lock the brakes.

Failure to follow these instructions may result in a loss of vehicular control and/or a collision, which may cause property damage, personal injury or even death.

- The pulley must be attached directly to metal – if the mounting location is carpeted, a section large enough for the pulley must be removed.
- The pulley must be mounted on a relatively flat surface (Figure 6).

CAUTION

If the pulley is not mounted on a flat surface, the pulley bracket may be bent when it is attached. This will create a gap between the bracket and the pulley wheel. If the cable should enter this gap it will lock in place, which will cause non-warranty damage to the towed vehicle's brakes and tires as well as other, consequential damage.

Note: if there is no flat surface to mount the pulley due to curves, recesses or obstructions in the firewall, an optional pulley mounting bracket (Figure 7) is available from ROADMASTER.

- The pulley will be attached with four 5/16" self-tapping screws. Make certain that the screws will not damage any components or electronics on the other

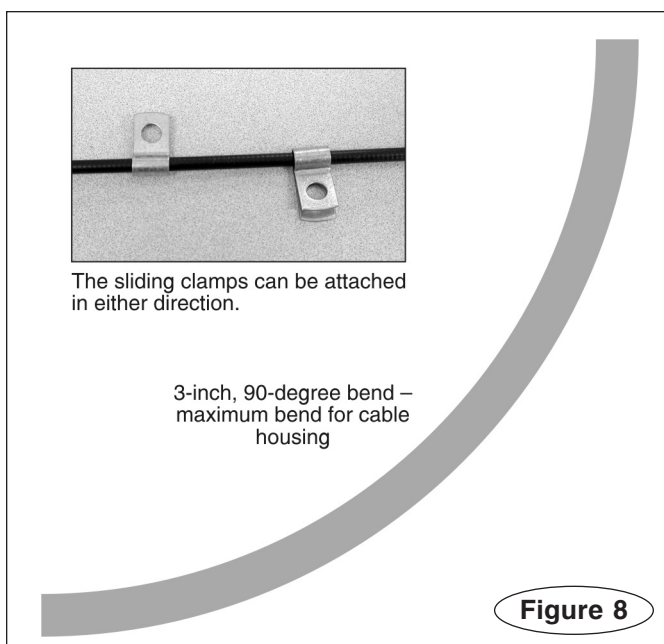

side of the firewall.

Do not attach the pulley or brake pedal clamp now.

Choose a mounting location for the cable anchor bracket and cable assembly

Based on where you will attach the pulley and brake pedal clamp, find the mounting location for the cable anchor bracket (Figure 1). This point must...

- ...position the cable directly in line with the pulley.
- ...take up all of the slack in the cable without depressing the brake pedal.
- ...allow the cable housing and air cylinder to be out of the way and hidden. A typical route is along the driver's side kick panel and underneath the door trim, paneling or carpeting – try to position the air cylinder under the driver's seat. However, the cylinder can be located under the passenger's seat, the center console or the dashboard. Or, depending on the interior design of the vehicle, there may be a more suitable location.

Make certain that the route you choose, as well as the mounting location for the cable anchor bracket, will cause no more than a three-inch, 90-degree bend. Refer to Figure 8.

CAUTION

Do not bend the cable housing further than a three-inch, 90-degree bend. Otherwise, InvisiBrake will not release braking pressure after it is activated, which will cause significant non-warranty damage to the towed vehicle's brakes and tires. Other consequential, non-warranty damage may also occur.

Choose a path for the cable

Choose a route for the cable with as few curves as possible. The more curves there are, and the tighter the bends are, the more you will have to increase the air pressure to receive adequate braking.

Begin the installation — attach the brake pedal clamp; attach the pulley; attach the cable anchor bracket

Note: do not attach any component until you have chosen mounting locations for the controller, pulley and air cylinder — see “Plan the installation,” beginning on page five.

Attach the brake pedal clamp

1. Now that you know where all the cable components go, position the two sections of the brake pedal clamp opposite each other. Using the two attachment points (Figure 3) closest to the brake pedal arm, attach the clamp with the two 10-24 x 1½" Allen head bolts and 10-24 Nylock nuts. Finger-tighten the nuts only; you may have to adjust the clamp later.

Be certain the clamp is as low as possible on the brake pedal arm.

2. Attach the adjuster sleeve to the brake pedal clamp – completely unthread the retaining nut (Figure 4) and insert the adjuster sleeve through the hole in the L-shaped bracket.

Finger-tighten both nuts so that the adjuster sleeve is roughly centered on the hole in the L-shaped bracket; you will adjust the cable later.

Attach the pulley

1. Route the bare cable over the pulley and position the pulley at the mounting location you have chosen. Make certain that both clips and posts (Figure 5) are present.

Make certain that the cable is in a straight line from the brake pedal clamp to the pulley. If it is not, you can...

- ...rotate the pulley, and/or
- ...move the pulley to a different location, and/or
- ...attach the brake pedal clamp in a different way.

2. With four of the 5/16" self-tapping screws, attach the pulley. **You must use all four screws.**

3. With a 5/32" Allen wrench and an adjustable wrench, tighten the two nuts at the brake pedal clamp to secure the clamp in place. Make certain that the cable is aligned directly to the pulley (Figure 9).

⚠ WARNING

Make certain that no part of the clamp interferes with the full and complete movement of the brake pedal arm, as shown to the right. Property damage, personal injury or even death may occur if the brake pedal cannot be operated at its full range.

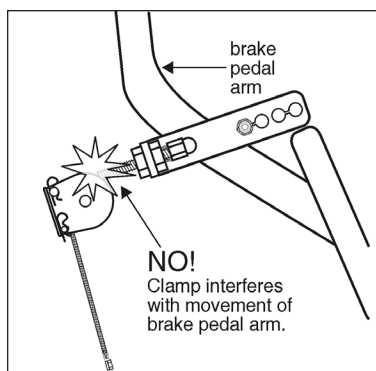

4. Make certain that no part of the brake pedal clamp, and/or the two Allen head bolts, will interfere with the driver's foot or the normal operation of the vehicle. If they will, trim them.

⚠ WARNING

Trim the brake pedal clamp, and or the two 10-24 x 1½" Allen head bolts, if they will present an obstruction or hazard to the driver of the vehicle or interfere with the operation of the vehicle.

Failure to follow these instructions may cause a loss of vehicular control, resulting in property damage, personal injury or even death.

Attach the cable anchor bracket

1. Position the cable anchor bracket at the mounting location you chose earlier. Check to make certain that the cable is in a straight line to the pulley (Figure 10.) and that there is no slack in the cable. Also check to make certain there are no sharp bends near the cable anchor bracket (Figure 11).

continued on next page

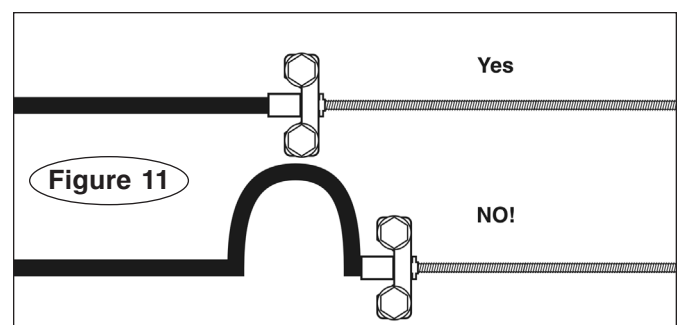
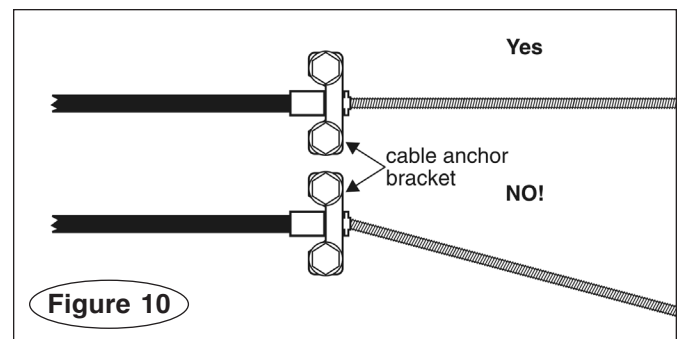
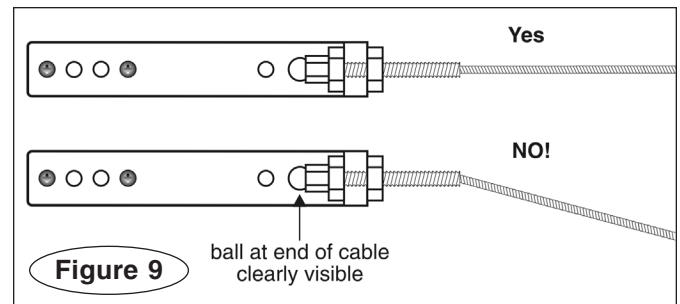

Attach the cable anchor bracket

continued from preceding page

CAUTION

Do not allow sharp bends near the cable anchor bracket. Tight bends will create internal friction between the cable and housing, reducing the efficiency of the braking system, and may cause non-warranty damage.

2. Move the cable anchor bracket forward or back-

ward until the ball at the end of the cable is clearly visible, as shown in Figure 9. This will allow 1/4" of free play in the cable.

3. With two of the 3/8" self-tapping screws, attach the cable anchor bracket.

4. Check the towed vehicle's brake lights to make certain that attaching the cable anchor bracket has not caused the brakes to be applied. If they have been, readjust the brake pedal clamp or the adjuster sleeve (see the next section).

Adjust the cable for 1/4" of free play

1. A 1/4" of free play is necessary to ensure that the towed vehicle's brakes will not be applied unless the supplemental braking system is activated.

If you do not have 1/4" of free play, adjust the cable by moving the retaining nut and locking nut (Figure 4) forward or backward on the adjuster sleeve. This will remove or gain up to 1/2" of slack in the cable.

2. When the ball at the end of the cable is clearly visible (Figure 9), tighten the nuts with two 1/2" wrenches.

3. If you are unable to adjust the cable sufficiently,

you must reposition either the brake pedal clamp and/or the cable anchor bracket.

CAUTION

Adjust the cable to allow 1/4" of free play, as directed. Otherwise, the towed vehicle's brakes may be applied continuously, which will cause severe tire and brake system damage. Other consequential, non-warranty damage may also occur.

Route the cable housing and attach the air line

1. Route the cable as planned and attach the air cylinder with the band clamp using a 3/8" self-tapping screw, as shown in Figure 12.

2. If necessary, use one of the sliding clamps (Figure 8) to secure the cable housing in place.

3. Attach the 1/8" air line to the air cylinder – press one end of the line into the port on the air cylinder (Figure 12) until it bottoms out. Route the air line to the controller and, if necessary, trim the line to length – make a smooth, straight cut – then press the other end of the line into the port on the controller (Figure 12) until it bottoms out.

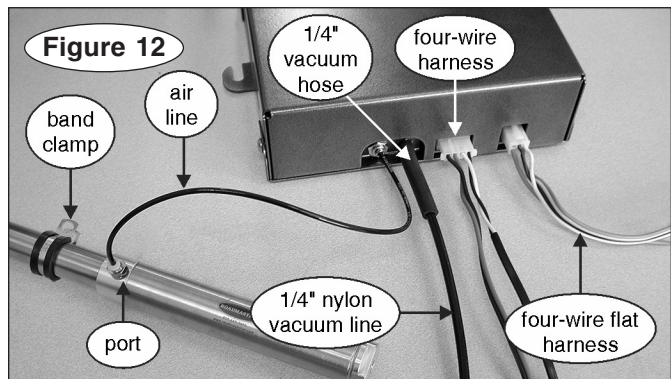

Attach the vacuum line

Note: the vacuum line is used on vehicles with vacuum-assisted power brakes. If the vehicle has a full-time ("active") power braking system it will not have a power brake booster (Figure 13). Accordingly, there is no need to install any of the components in this section. Leave the vacuum port as is and proceed to the next section — "Check the existing wiring."

1. Use a section of 1/4" rubber vacuum hose to attach the 15-foot section of 1/4" nylon vacuum line to the controller, as shown in Figure 12.

Note: in most applications, a hose clamp or other crimping device is not required for this connection. However, check to make certain the vacuum hose is secure after you have operated InvisiBrake — see "Test the system."

2. Seal the open end of the nylon line with tape. Then route the vacuum line from the controller to the firewall. Choose a route that will conceal the vacuum line.

3. Look for a pre-existing hole with a rubber grommet in the firewall and route the nylon vacuum line through it.

If there is no pre-existing hole, drill a 1/2" hole through the firewall. **Before drilling, make certain you will not damage any components on the other side.**

4. Route the vacuum line through the engine compartment and to the power brake booster (Figure 13). Avoid moving parts, sharp edges or hot components such as the engine or exhaust system. Do not kink the vacuum line, or bend it to the extent that it crimps or creases.

⚠ WARNING

Do not position the vacuum line close to any heat source. The heat will soften the nylon, which will cause the vacuum line to rupture. If the vacuum line is ruptured, the vehicle's brakes (as well as the supplemental braking system) will not function properly.

A loss of vehicular control may result if the towed vehicle's brakes do not function properly, which may cause property damage, personal injury or even death.

CAUTION

Do not kink the vacuum line, or bend it to the extent that it crimps or creases — vacuum pressure will be substantially reduced, or blocked entirely, at the kink in the line. If vacuum pressure is reduced, InvisiBrake will not function properly.

5. Locate the vacuum line coming out of the power brake booster and cut the line in two places.

⚠ WARNING

Do not drive the vehicle until this installation is complete — once the vacuum line is cut, the vehicle's power brakes will not function. Consider-

able force will be required to apply the brakes and braking distance will be subsequently lengthened, which may cause property damage, personal injury or even death.

6. Insert the check valve and tee as shown in Figure 14.

Note: two sizes of vacuum line tees are provided for varying applications.

Insert the check valve between the engine and the tee. Position the check valve so that the barbed fitting with the red band (Figure 14) is closest to the engine, and that the arrow on the check valve (Figure 14) is pointing toward the engine.

Note: some check valves are half black and half clear. These check valves are installed with the black side pointing toward the engine.

CAUTION

The supplemental braking system will not function if the check valve is inserted with the arrow pointing away from the engine.

7. Press the 1/4" rubber vacuum hose over the bottom of the tee, as shown in Figure 14.

8. Remove the tape and, if necessary, cut the 1/4" vacuum line from the controller to length. Insert the open end into the 1/4" rubber vacuum hose (Figure 14).

9. Make certain that all connections are secure.

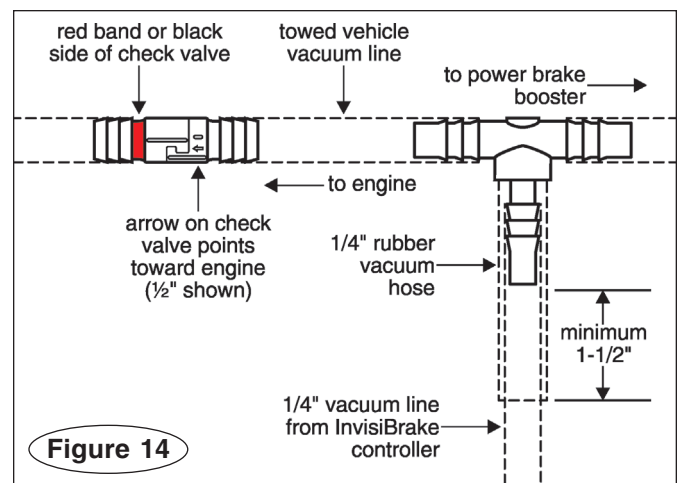
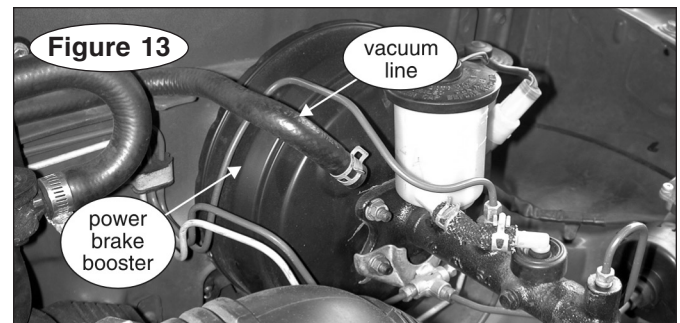

Check the existing lighting

In order for InvisiBrake to function properly, the lighting systems on both vehicles must also function properly.

Before proceeding with the installation...

1. Check the proper function of the brake, turn signal and running lights on the towed vehicle.
2. Independently check the proper function of the brake, turn signal and running lights on the motorhome.
3. Position the vehicle behind the motorhome and connect the tow lighting electrical cord between the two

vehicles.

Do not connect the tow bar or the safety cables – they may act as a false ground.

4. Use the motorhome to activate the towed vehicle's brake lights, turn signals and running lights.
5. If any lighting system does not operate properly, identify the source of the problem and correct it before proceeding. Otherwise, InvisiBrake will not work.

Note: if the towed vehicle's lights appear dim the most likely cause is a poor ground in the motorhome and/or towed vehicle.

Install the break away system; attach the power and ground wires

1. Attach the four-wire harness (Figure 15) to the corresponding connector on the InvisiBrake controller. Route the other end through the hole in the firewall. Use the same route as the 1/4" vacuum line, if that is convenient.

2. Using the 1" bolt and lock nut (Figure 15), mount the break away switch (Figure 15) at the front of the vehicle. Choose an area you can easily reach, near the center of the vehicle, with a surface of sufficient strength to hold the switch firmly in place, so that the break away pin (Figure 15) will pull freely from the switch.

Mount the switch in a horizontal position, with the break away pin facing the motorhome.

Make certain that the break away pin can be pulled freely away from the towed vehicle, without any obstructions.

3. Route the bundled pair of black wires to the front of the vehicle and plug them into the break away switch.

4. Route the bonded pair of black and red wires to the towed vehicle's battery (or if the battery is inaccessible, to an appropriate power source which will be energized when towing). Using the two 3/8" ring terminals, connect the wires as shown on page two.

Make certain to install the 20-amp fuse.

Note: before attaching the wires, check the owner's manual to make certain that aftermarket accessories can be grounded to the negative battery terminal. If they cannot, attach the black wire to any good chassis ground, preferably directly to the chassis.

Note: if the vehicle owner's manual indicates that the battery must be disconnected for towing, the wires must be routed directly to the battery or InvisiBrake will not work.

Note: an Automatic Battery Disconnect (part number 765) and stop light switch kits for most popular towed vehicles are available through ROADMASTER.

WARNING

Do not attach the break away switch to the tow bar. In the unlikely event that the tow bar should separate, the break away switch will separate with it, preventing the break away system from activating. The towed vehicle's brakes will not be applied, which may cause property damage, personal injury or even death.

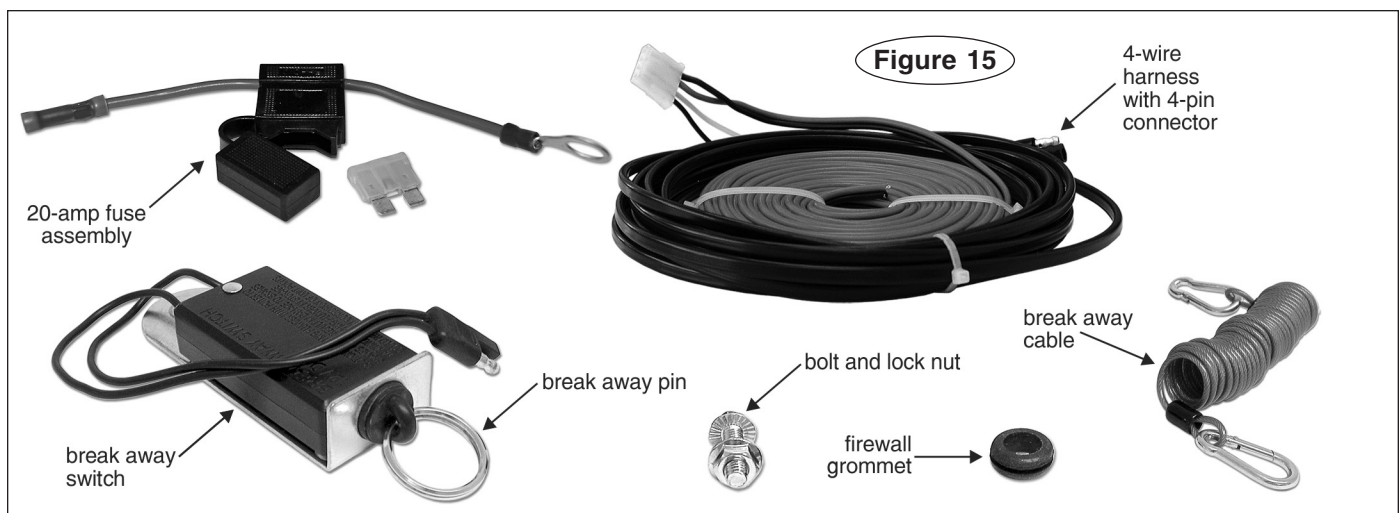

Attach the four-wire flat harness; attach the controller

Note: the following wiring instructions are based on a typical connection from the motorhome. For other wiring applications, contact ROADMASTER.

CAUTION

If the towed vehicle's turn signals, taillights and brake lights have been wired for towing, the connection you are about to make to the aftermarket tow light harness must be upstream of the wiring diodes.

If it is not, InvisiBrake will not function properly. Severe damage to the towed vehicle's tires and brakes, as well as other consequential, non-warranty damage, may also occur.

(If a bulb and socket wiring system has been used, diodes are not necessary.)

CAUTION

Failure to establish good ground connections WILL CAUSE non-warranty electrical damage to InvisiBrake. Other consequential non-warranty damage may also occur.

A good ground connection MUST EXIST...

- ...between the towed vehicle and motorhome;
- ...between InvisiBrake and the towed vehicle; and

• ...between InvisiBrake and the motorhome.

If the towed vehicle has been wired for towing, check to make certain a good ground exists between the towed vehicle and the motorhome; refer to the illustrations below and to the complete wiring schematic near the beginning of these instructions for InvisiBrake ground wire connections.

1. Attach the four-wire flat harness with the six-pin connector (page one) to the corresponding connector on the controller.

2. Route the harness to the vehicle's aftermarket tow light harness.

3. Find a convenient point to attach the wires to the aftermarket tow light harness.

With a test light, identify the ground, right turn, left turn and taillight wires in the tow light harness.

Typically, the wires are color-coded as follows:
 white ground
 greenright turn and brake
 yellowleft turn and brake
 brown..... taillights
 any color..... brake

CAUTION

Color coding is not standard with all manufacturers. Use the color codes listed above for initial reference only; confirm the function of each wire with a test light.

The vehicle's lighting system may not function, or function improperly, if the wires are not connected correctly. Cross-wiring may also cause a short circuit, a blown fuse or other electrical damage.

4. Refer to Figure 16 or 17 and to the complete wiring schematics near the beginning of these instructions to attach the four-wire flat harness.

5. All connections have now been made to the controller. With two of the 3/8" self-tapping screws, attach the controller at the mounting point you chose earlier.

If the mounting point is carpeted and hidden from view, you can attach the controller by cutting two small slits in the carpet. This method eliminates the two self-tapping screws. Position the controller and cut a 1¼-inch slot at the point where one of the mounting flanges (Figure 18) is attached to the controller. Slide

continued on next page

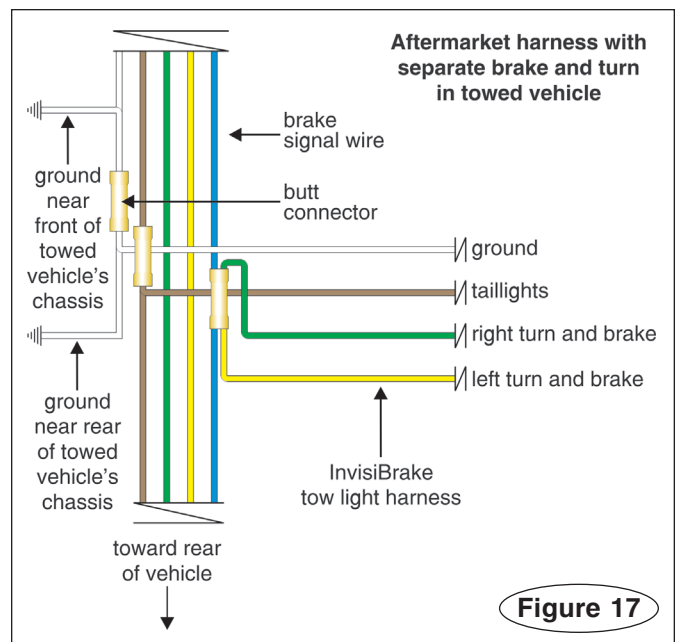
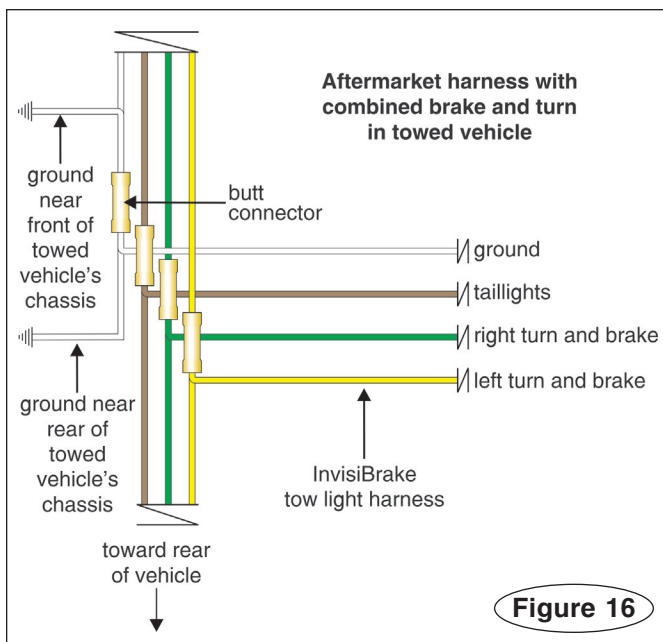

Attach the controller

continued from preceding page

the flange under the carpet.

Repeat for the remaining side; with a pair of pliers bend this flange down 45° and slide it under the carpet. Press down on the controller above the flange to straighten the flange and secure the controller.

6. You will test and adjust for proper braking pressure in a later step. So leave the brake pressure adjustment knob on the controller (page four) accessible – do not reinstall any trim panels that would prevent adjusting the brake pressure.

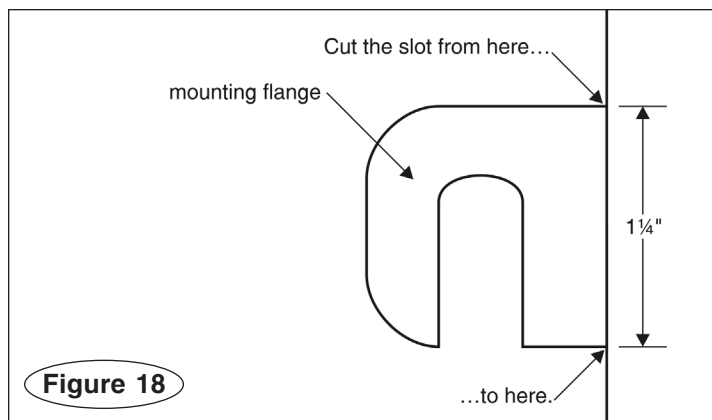

Install the monitor system

1. Follow all of the steps in the owner's manual to prepare the vehicle for towing (for example: neutral; ignition switch position; pull fuses; etc.).

2. Apply the brakes and check to see if the brake lights illuminate. If they do not, an optional stop light switch kit must be installed – visit www.roadmasterinc.com.

Note: check the owner's manual to see if the vehicle has an "automatic shut down" feature. If so, an optional stop light switch kit must be installed, as the brake light switch will stop working at some point during towing.

3. Choose a mounting point at the front of the vehicle, near the electrical socket, for the end of the 15-foot harness with a female bullet connector.

Attach the connector with one or more wire ties; allow enough slack so that a matching connector can be plugged into and out of it.

4. Route the other end of the harness through the engine compartment and through the hole in the firewall. Use the same route as the break away wiring harness, if that is convenient.

5. Locate the towed vehicle's brake light switch. With a multi-meter, find the "cold" side of the switch. (The cold side of the switch does not register voltage unless the brakes are applied.)

Remove the vehicle's brake light fuse.

CAUTION

Failure to remove the brake light fuse may cause the vehicle's theft deterrent system, or other electrical system indicators, to be activated if the brake pedal is depressed during the installation. This may require non-warranty repair to the vehicle.

6. Cut the brake light wire, a few inches downstream from the cold side of the brake light switch.

Note: if a Brake-Lite Relay is installed, the connection must be between the Brake-Lite Relay and the brake light switch.

7. If necessary, trim the monitor wiring harness. Attach the monitor wire and one end of the wire from the cold side of the brake light switch to one side of a yellow butt connector.

Attach the other end of the wire from the brake light switch to the other end of the yellow butt connector.

8. Reinstall the brake light fuse.

Seal the firewall

1. If you had to drill a hole through the towed vehicle's firewall, cut the grommet (Figure 15) on one side, and slide it over the nylon vacuum line, the monitor harness and all of the electrical wiring from the controller.

Fit the grommet into the hole in the firewall.

2. Completely seal the grommet with a silicone sealant.

Note: failure to seal the grommet completely may allow engine fumes and water into the passenger compartment.

3. Reattach the door trim, paneling or carpeting over the vacuum line, cable housing and the electrical wiring from the controller.

Connect the monitor wire patch cord

1. Attach the male bullet connectors on the monitor wire patch cord (page four) to the matching connectors on the motorhome and towed vehicle.

Note: if an open terminal is available on both electrical sockets, you can use the existing power cord to connect the monitor wiring between the two vehicles. This method eliminates the monitor wire patch cord.

You must apply a silicone sealant (not provided) to weatherproof the attachment points. Otherwise, moisture and/or corrosion may cause unintended activation.

2. The installation is complete. Before operating InvisiBrake you must test all functions, as described in the next section.

Test the system; evaluate the brake pressure setting

Test drive the motorhome

Drive the motorhome for a short distance, making a few stops. Get a good feel for the motorhome's braking ability. Later, you will compare how the motorhome brakes by itself with how it brakes with the towed vehicle and InvisiBrake.

Connect the vehicles for towing

1. According to the manufacturer, make all adjustments necessary to prepare the vehicle for towing. Refer to the owner's manual or call the dealership for vehicle-specific information.

2. Make all connections between the towed vehicle and the motorhome, including tow bar, wiring kits, monitor wire patch cord, etc.

Test the system with the motorhome running

The following tests can be performed with the motorhome and towed vehicle stationary. However, the motorhome engine should be running, as many motorhomes do not supply enough voltage to activate InvisiBrake unless the engine is running.

1. **Confirm braking** – with the motorhome engine running, depress and hold the motorhome brake pedal down. The towed vehicle's brake pedal will be depressed. Then, release the motorhome brake pedal. At the towed vehicle, the brake pedal will retract.

Confirm that the ¼" vacuum hose (Figure 12) is attached to the controller. If it is not, use a hose clamp or other crimping device to hold it in place.

WARNING

If the vacuum hose has come loose, use a hose clamp or other crimping device to hold it in place.

Otherwise, InvisiBrake will not function. Insufficient braking pressure will lengthen stopping distance, resulting in property damage, personal injury or even death.

2. **Confirm that the motorhome monitor is functioning** – the LED will illuminate after the motorhome's brake pedal is depressed and stop illuminating when the brake pedal is released.

3. **Confirm the proper operation of the extended braking protection mode** – depress and hold the motorhome's brake pedal down. The towed vehicle's brake pedal will be depressed. After approximately 15 seconds, the brake pedal will retract, even though the motorhome brake pedal is still depressed.

4. **Confirm the proper operation of the audio alert** – in the towed vehicle, depress and hold the brake pedal down. After approximately 20 seconds, the audio alert will sound in the motorhome. (To cancel the audio alert, release the towed vehicle's brake pedal.)

WARNING

If InvisiBrake fails any of the above tests, you

must refer to the "Troubleshooting" section in the owner's manual and repair the fault before towing.

Failure to follow these instructions may cause property damage, personal injury or even death.

Results of system test –

Passed Failed

Test performed by: _____ Date: _____

Return this document to the owner of the vehicle.

Evaluate the braking pressure

InvisiBrake's braking pressure has been pre-set at the factory at a level appropriate for most towed vehicles. While there may be no adjustment necessary, you **must** evaluate the braking pressure. As a starting reference only, visit www.roadmasterinc.com and click the 'Vehicle Specific Info' tab. Select 'InvisiBrake' to view a list of recommended starting brake pressure settings for many popular towed vehicles.

However, do not simply set the pressure according to the chart. In addition to the vehicle's make, model and year, the correct pressure is also dependent upon...

- ...whether the brake pedal clamp is positioned as low as possible on the brake pedal arm; and
- ...the number of curves in the cable between the cable anchor bracket and the air cylinder.

The higher the clamp is positioned on the brake pedal arm, and the more curves in the cable, the higher the braking pressure must be set.

continued on next page

For vehicles with full-time ('active') power braking systems...

IMPORTANT – if the towed vehicle is a hybrid or a Hummer H3 it may have full-time ('active') power brakes. A vehicle with 'active' brakes will have power brakes even with the ignition off.

If the towed vehicle does have full-time ('active') power brakes, the brake pressure setting **must** be lower than the factory setting before proceeding with the test – First, follow the instructions under "If necessary, change the brake pressure setting" (on the next page) to lower the setting. Then go to "Test-drive the motorhome and towed vehicle" (below).

CAUTION

If the towed vehicle has full-time ('active') power brakes, the brake pressure setting must be lowered before the test drive. Otherwise, InvisiBrake will apply excessive force to the towed vehicle's brakes, which will 'flat-spot' the tires, damage the braking system or cause other non-warranty damage.

Test the system; evaluate the brake pressure setting

continued from preceding page

Test-drive the motorhome and towed vehicle

1. Drive the motorhome and towed vehicle for a short distance, making six to eight stops.

The degree to which the brake pressure setting will affect the motorhome will vary, depending on the size and weight of the motorhome in comparison to the size and weight of the towed vehicle –

- **Brake pressure set too high** – a sharp pull at the motorhome indicates that the brake pressure is set too high – in this case, you may choose to lower the setting until the towed vehicle brakes with less force. See “If necessary, change the brake pressure setting,” below.

WARNING

It is possible to lower the brake pressure setting to the point that it negates the benefit of the supplemental braking system and break away. Insufficient brake pressure will lengthen stopping distance.

Failure to follow these instructions may cause property damage, personal injury or even death.

- **Brake pressure set too low** – if the combination of vehicles takes longer to stop than the motorhome alone, you may choose to raise the setting. See “If necessary, change the brake pressure setting,” below.

WARNING

If brake pressure is set too high, InvisiBrake will apply excessive force to the towed vehicle’s brake pedal, which will cause tire and brake system damage, as well as other consequential, non-warranty damage.

Failure to follow these instructions may cause property damage, personal injury or even death.

If necessary, change the brake pressure setting

1. Pull the break away pin (Figure 15). The pressure gauge on the controller (page one) will display the current braking pressure.

CAUTION

Reinsert the brake away pin within five minutes, or premature compressor failure may result.

2. Pull out on the brake pressure adjustment knob (page one) to unlock it. Turn the knob clockwise to increase the braking pressure or counterclockwise to decrease the braking pressure.

3. Adjust the pressure by no more than 10 psi.

4. Push the brake pressure adjustment knob in to lock it in place. Reinsert the break away pin.

5. Repeat the test drive and, if necessary, adjust again until you are satisfied with the brake pressure setting.

WARNING

Every time you adjust the brake pressure, you must test drive the motorhome and towed vehicle. After repetitive braking, check for excessive heat near the center of the towed vehicle’s wheels — this indicates that the brakes are overheating and that the brake pressure is set too high.

You must lower the braking pressure and re-test until the brakes are not excessively hot.

Failure to follow these instructions may cause brake failure, resulting in property damage, personal injury or even death.

Finish the installation

The installation and tests are complete. If necessary, replace any trim panels that were removed to install the controller.