

visit roadmasterinc.com/patents for patent information

non-binding tow bar
8,000-pound GVWR capacity
part number 676 (and 677 with Blue Ox ears)

Owner's Manual

Entire contents of manual must be read by owner



Time Tested • Time Proven

ROADMASTER, Inc. • 6110 NE 127th Ave. • Vancouver, WA 98682

800-669-9690 • Fax 360-735-9300 • roadmasterinc.com

© 2023 ROADMASTER, Inc. All rights reserved. 855616-19 12.23

Welcome to the Roadmaster family!

This manual has been prepared to acquaint you with the installation, operation, care and maintenance of your tow bar, and to provide you with important safety information.

Read your owner's manual cover to cover. Understand how to install and operate your tow bar, and carefully follow the instructions and safety precautions.

We thank you for your patronage and greatly appreciate your discerning taste.

Table of Contents

Safety definitions	below
Safe towing practices	1-2
Connecting and disconnecting	
Connecting the tow bar	3-4
Disconnecting the tow bar.....	4-5
Stay within the 'Safe Zone'.....	5
Safety cables	
Attaching the safety cables and power cords	6
How to use safety cables.....	7
Care and cleaning	7
Electrical	8
Tow bar parts.....	back page

Save this manual

Save this manual for future reference. It contains important sections relative to safety, use, maintenance, parts replacement and other information. Therefore, make sure this manual is always with you when you're towing. You may download or print a copy of the most current manual at www.roadmasterinc.com (under 'Support').

WARNING

Read all instructions before installing the tow bar or before towing a vehicle. Failure to understand how to properly install or operate the tow bar could result in property damage, personal injury or even death.



Your tow bar serial number...

...is located on a label on the inside of the driver's side tow bar arm. You will need this number when you fill out your product registration card.

Write down the serial number in the space below and retain for future reference.

Serial number:

All illustrations and specifications contained herein are based on the latest information available at the time of publication. ROADMASTER, Inc. reserves the right to make changes, at any time, without notice, in material, specifications and models, or to discontinue models.

IMPORTANT NOTICE!

Safety Definitions

This manual contains information that is very important to know and understand. This information is provided for **safety** and to **prevent equipment problems**. To help recognize this information, observe the following symbols:

WARNING

WARNING indicates a potentially hazardous situation which, if not avoided, could result in property damage, serious personal injury or even death.

CAUTION

CAUTION indicates a potentially hazardous situation which, if not avoided, may result in property damage, or minor or moderate personal injury.

CAUTION

CAUTION used without the safety alert symbol indicates a potentially hazardous situation which, if not avoided, may result in property damage.

NOTE

Refers to important information and is placed in italic type. It is recommended that you take special notice of these items.

Safe towing practices

CAUTION

Do not back up the motorhome with the towed vehicle attached.

Backing up with the towed vehicle attached will cause the towed vehicle to “jackknife,” which will damage the tow bar, the baseplate, the receiver hitch, the towed vehicle’s front end, and/or the rear of the motorhome. Backing up with the towed vehicle attached is the primary cause of tow bar damage and will void the warranty.

- **Be sure the vehicle can be towed** before taking it on the road. Some vehicles must be equipped with a transmission lube pump, an axle disconnect, driveline disconnect or free-wheeling hubs before they can be towed. Failure to properly equip the vehicle will cause severe damage to the transmission.

Check the vehicle manufacturer’s instructions for the proper procedure(s) to prepare the vehicle for towing.

- **The tow bar must be within the ‘Safe Zone’** – no more than three inches above or below level. Towing with an out-of-level tow bar will cause significant wear and tear on the tow bar and baseplate, and on the towed vehicle’s suspension and frame. (See the section titled “Stay within the ‘Safe Zone’” for further information.)

- **The steering wheel must be unlocked and free to turn when towing.** Failure to do so can cause severe tire and equipment damage. Check the manufacturer’s instructions for the proper towing procedure(s).

- **The towed vehicle and all its contents cannot exceed 8,000 pounds.** The Nighthawk™ tow bar is rated at a maximum of 8,000 pounds carrying capacity; therefore the towed vehicle and all its contents cannot exceed 8,000 pounds.

In addition, the receiver hitch, the baseplate, the safety cables and all supplementary towing equipment must be rated at no less than the weight of the towed vehicle and all its contents.

- **The tow bar must be secured with lynch pins (or optional padlocks) before towing.** Unless the tow bar is secured to both vehicles with all appropriate pins (or padlocks), the towed vehicle will detach.

- **Inspect the system before towing** – check the mounts, brackets, fasteners, bolts, wiring, the safety cables and all other components each time before towing.

Additionally, check the baseplate every 3,000 miles – inspect for any fractures or cracks in the steel, or any visible damage. Do not tow if the baseplate is damaged.

Additionally, check the torque on all bolts. (To find the torque ratings, refer to the installation instructions for the baseplate and the tow bar.)

- **This tow bar is designed for use on paved roads only.** ROADMASTER does not recommend off-road towing, nor does ROADMASTER warrant the tow bar for off-road use.

- **Never tow a vehicle with one of a comparable weight.** The towed vehicle’s weight should never exceed 40 percent of the towing vehicle’s weight.

Towing a vehicle with one of similar weight will cause the towed vehicle to override the towing vehicle, resulting in “jackknifing,” “leapfrogging” or “fishtailing.” Serious damage to both vehicles, as well as the towing system, could result.

- **Do not drill a second hole in the shank of any tow bar or hitch accessory.** If the hole in the shank does not align to the hole in the hitch receiver: 1) purchase a hitch accessory of the appropriate length; or 2) call ROADMASTER technical support.

Drilling a second hole will weaken the steel. The shank may break during towing, which will cause the towed vehicle to separate.

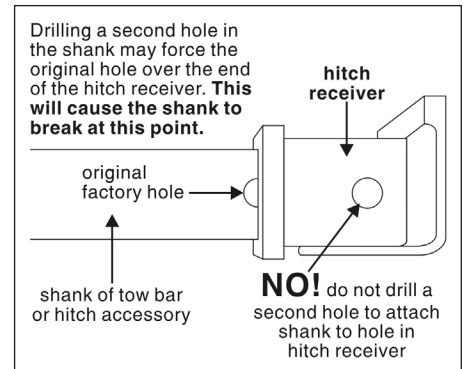

- **Always stand to one side and as close to the motorhome as possible when releasing the tow bar locking mechanisms.** Never stand between the adjustable arms, or put any part of your body between the adjustable arms, when releasing the tow bar – always stand to one side. Because the towed vehicle may jerk forward when the locking mechanisms are released, face the towed vehicle and stand as close to the back of the motorhome as possible before releasing the locking mechanisms, to keep from being hit by the towed vehicle.

- **Always use safety cables when towing.** The safety cables, which are provided with the Nighthawk™, must connect the towed vehicle to the towing vehicle frame to frame.

If the safety cables are ever replaced, use only 8,000 pound capacity or heavier rated safety cables.

Additionally, check to ensure that the safety cables are the proper length. Refer to the sections titled “How to use safety cables” and “Attaching the safety cables and power cords” for further information.

- **Check the motorhome turning radius.** Some motorhome chassis have such a tight turning radius that you can damage your motorhome, towed vehicle or tow bar while turning too sharply. Before getting on the road with your towed vehicle, you should test your turning radius in an empty parking lot.

With the towed vehicle attached, have someone watch as you slowly turn sharply to see whether you have this potential problem. If you do, note how far you can safely turn the motorhome’s steering wheel and be sure not to turn it further when towing. Damage that results from turning too sharply is not covered by warranty.

continued on next page

Safe towing practices

continued from preceding page

- **Never use the tow bar to tow more than one vehicle.** In some states it is legal to have one vehicle towing more than just one vehicle (for example, a truck which is towing a trailer which is towing a boat). However, when using a tow bar never tow more than one vehicle, or non-warranty damage or injury may result.

- **The tow bar stinger fits motorhome hitch receivers with two-inch inner diameters.** If the motorhome hitch receiver is a larger size, attach a two-inch adaptor sleeve (not supplied) to the hitch receiver.

Damage to the tow bar stinger or other components of the tow bar, abnormal wear patterns on the towed vehicle's tires, as well as other, consequential damage may result if an adaptor sleeve is not used.

- **Keep the tow bar clean and well-lubricated.** As is the case with most precision equipment, frequent cleaning and care results in better performance and longevity. Refer to the section titled "Care and cleaning" for further information.

- This tow bar is equipped with a row of LEDs along each outer arm. **If the tow bar is stored on the back of the motorhome, disconnect the power cord (or use the optional cover, part number 055-3) when the motorhome is driven.** Otherwise, the LEDs may create a distraction to other drivers.

WARNING

Failure to follow these instructions may cause property damage, personal injury or even death.

Figure 1

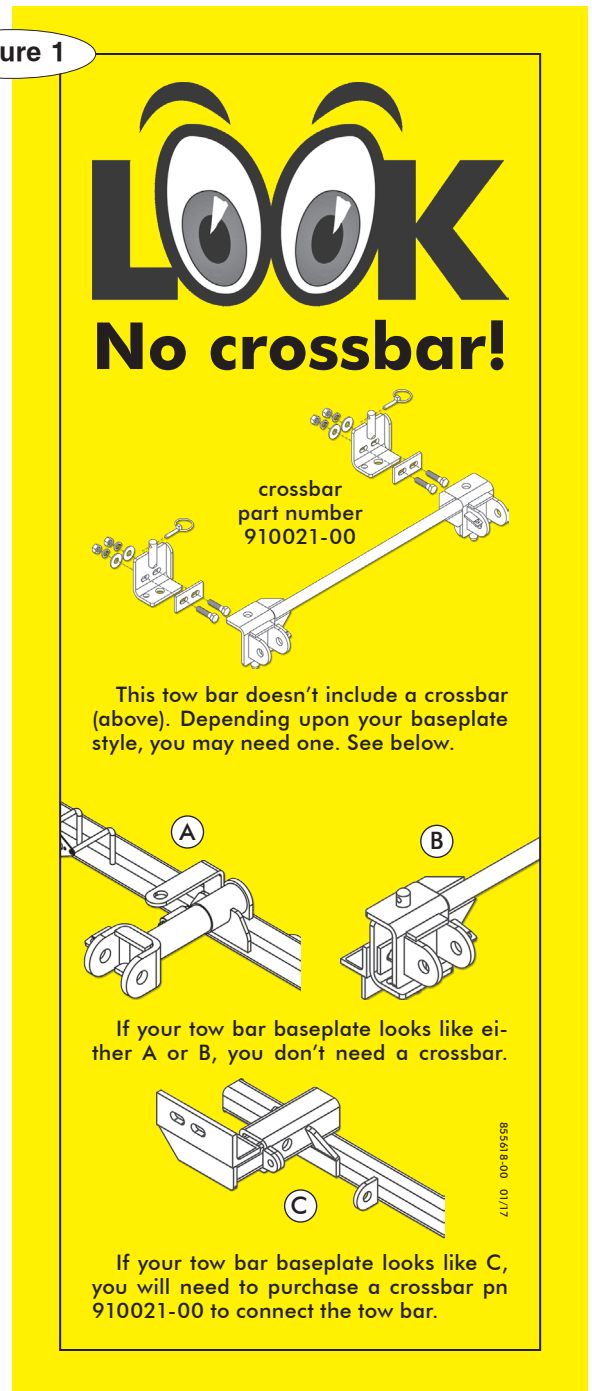

Connecting the tow bar

CAUTION

Use caution when handling the tow bar – if your hands, fingers or any part of your body is caught between moving components, it can be pinched, cut or otherwise injured.

Note: before beginning, make certain you don't need a crossbar (Refer to Figure 1 on the preceding page.) – the Nighthawk™ is designed to be attached directly to the tow bar baseplate. The ROADMASTER baseplate styles that accommodate the Nighthawk are EZ5 Twistlock™, MX and MS. Optional equipment will be required to adapt the Nighthawk to other baseplates.

1. With the tow bar arms together (Figure 2), insert the tow bar stinger into the motorhome receiver and secure it with the hitch pin and clip.

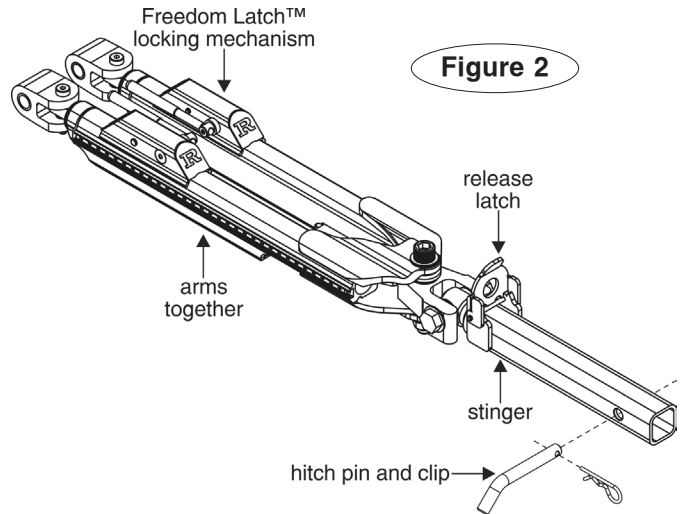

CAUTION

Attach the tow bar so that the locking mechanisms and the release latch are pointing up. If they are pointing down, the tow bar may be damaged.

2. Drive the vehicle to be towed within three or three-and-a-half feet of the motorhome hitch receiver. The vehicle doesn't have to be perfectly centered to the hitch receiver, just close.

Put the vehicle in park, set the emergency brake and chock one of the wheels.

3. Keep both tow bar arms together. Standing to one side, swing both arms away from you.

Align the holes at the end of the outermost tow bar arm with the holes in the corresponding tow bar baseplate. Secure it with one of the base pins, as shown in Figure 3.

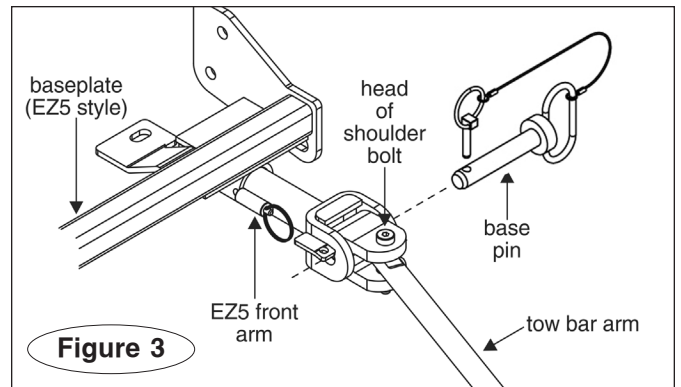

(If you fully extend the tow bar arm, it will lock. To unlock the arm, pull up on the Freedom Latch release handle, as shown in Figure 4.)

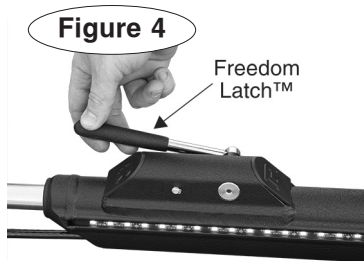

Attach the arm so that the head of the shoulder bolt (Figure 3) is facing up.

Lock the base pin with a linch pin (Figure 5).

The linch pin must be locked. The ring (Figure 5) is spring-loaded – it must be snapped over the pin, as shown in Figure 5, with the curved side of the linch pin touching the ring, in order to keep the base pin secure.

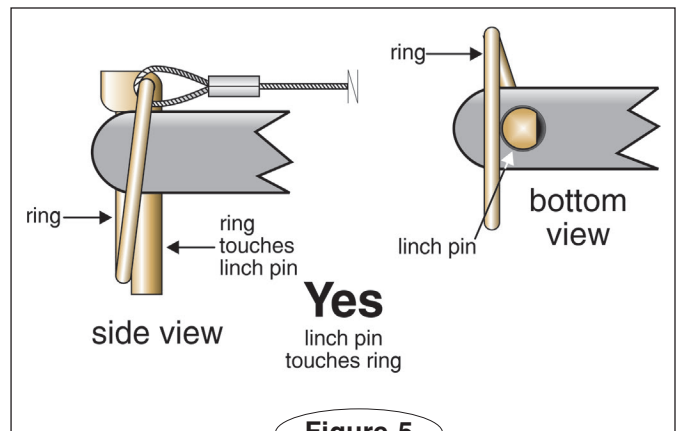
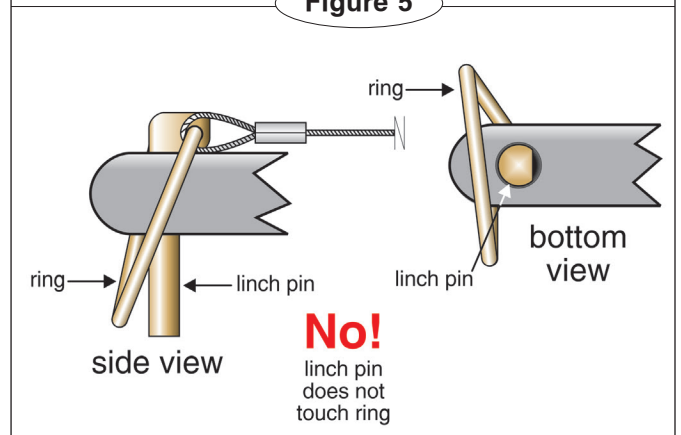

Figure 5



WARNING

Towing vibrations will force the linch pins out unless they are properly locked over the base pins.

Failure to properly lock both base pins will result in the loss of the towed vehicle, which may cause property damage, personal injury or even death.

4. Swing the other arm to the opposite side and connect
continued on next page

Connecting the tow bar

continued from preceding page
it in the same manner.

ROADMASTER recommends replacing at least one of the linch pins with a padlock (part number 301, 302 or 308) to prevent accidental release or theft.

5. Attach the safety cables and plug in the power cord (see pages 6 and 7).

Before towing the vehicle, be sure the steering is unlocked, the transmission is in the proper setting, and the emergency brake is released. Remove the wheel chock.

Check the manufacturer's specifications, the owner's manual or talk to the installer for the proper towing procedure(s) or requirement(s) for the vehicle to be towed.

WARNING

Do not tow the vehicle until the tow bar is attached with all pins or padlocks. Unless the tow bar is se-

ured to both vehicles with all appropriate pins or padlocks, the vehicle will detach, which may cause property damage, personal injury or even death.

6. When you drive away, steer briefly to the left and then to the right, to extend, self-center and lock the tow bar.

Always stop at this time. Check the tow bar to ensure that both arms are locked before assuming highway speed. Check the other components of your towing system, to ensure they're fully engaged.

WARNING

Both tow bar arms must be locked before towing. If they are not, the momentum of the towed vehicle will apply excessive force to the tow bar arms and other components of the towing system, which may cause the towing system to fail, resulting in property damage, personal injury or even death.

Disconnecting the tow bar

1. Disconnecting the tow bar is essentially the reverse of connecting it. First, always try to park on level ground, with the towed vehicle in line with the motorhome. This will eliminate most of the tension between the vehicles, allowing for an easier disconnect.

2. Disconnect the power cord, safety cables and any other towing system accessories from the towed vehicle.

3. Lift the Freedom Latch release handles on each tow bar arm (Figure 6) to release the locking mechanisms.

WARNING

The towed vehicle may surge forward a short distance when you lift the release handles. For this reason: 1) face the towed vehicle and stand as close to the back of the motorhome as possible before releasing the handles; and 2) never stand between the tow bar arms, or put any part of your body between the arms, when you lift the release handles. Otherwise, you may be hit by the towed vehicle, which may cause serious personal injury or even death.

(Usually, one of the handles will require more pressure to release. This is the arm that has the majority of the tension between the two vehicles.)

WARNING

Always put the towed vehicle in park, set the emergency brake and chock one of the wheels after lifting the release handles, and before removing the base pins. Failure to do so may result in a 'runaway' vehicle or may crush you between the towed vehicle and the motorhome, causing property damage, personal injury or even death.

continued on next page

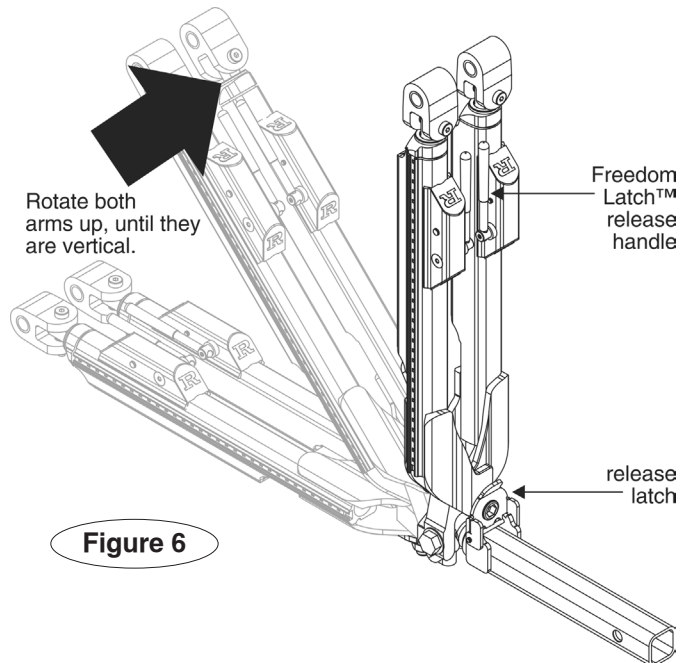

Figure 6

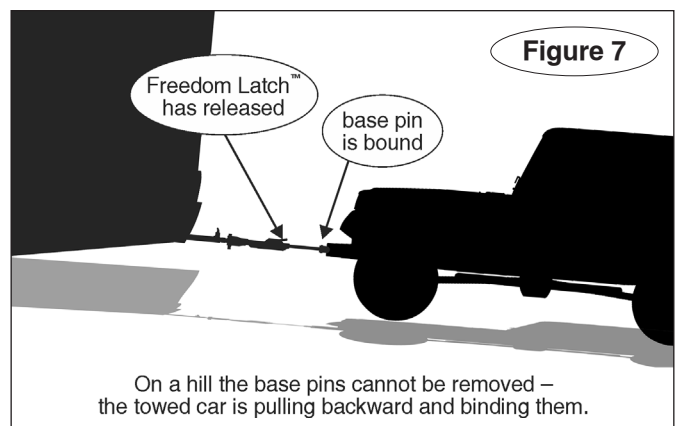

Figure 7

On a hill the base pins cannot be removed – the towed car is pulling backward and binding them.

Disconnecting the tow bar

continued from preceding page

- Put the towed vehicle in park, set the emergency brake and chock one of the wheels.
- Remove the base pins and store the tow bar on the motorhome – hold both tow bar arms firmly and rotate them up until they are vertical, as shown in Figure 6. The release latch will ‘click’ when the tow bar is locked in the upright position. (To release the latch, pull it forward.)

⚠ WARNING

Never release the tow bar arms when they are in the vertical position. The arms can fall and cause severe injury.

The tow bar can be stored with the arms rotated in either direction.

CAUTION

The tow bar can be stored on the motorhome with

the arms rotated to the left or the right. To avoid the possibility of damage to the bushings, rotate the arms away from the engine exhaust.

The bushings at the end of the tow bar arms can be warped by heat from the exhaust. If the bushings are warped, the tow bar arms will not slide easily, or they may not slide at all – it may be difficult to connect or disconnect the tow bar until the bushings are replaced.

Note: if you must park on an uphill incline, you may find that you cannot remove the base pins even with the tow bar arms released. The weight of the towed vehicle trying to roll back (Figure 7) is binding the pins in place.

Allow the towed vehicle to idle forward just enough to take the tension of this weight off the pins. Then hold the vehicle in position by first applying the emergency brake, then shifting into park.

Once the tension is off, lift the release handles again and the pins will slide out easily.

Stay within the ‘Safe Zone’

Towing with a motorhome-mounted tow bar which has an upward or downward slope puts undue strain on the entire towing system. For that reason, **do not tow if the tow bar is not within the ‘Safe Zone’ – no more than three inches above or below level.**

Towing a vehicle with a tow bar that is not within the Safe Zone will result in significant wear and tear on the tow bar and baseplate, significant wear and tear on the vehicle’s suspension and frame, and the eventual failure of the towing system.

To determine if the tow bar is within the Safe Zone – first, connect the motorhome and towed vehicle on level ground. Next, measure the distance from the center of the motorhome receiver (Figure 8) down to the ground. Then, measure the distance from the center of one of the base pins (Figure 8) down to the ground.

Compare these two measurements. To be within the Safe Zone, they cannot be more than three inches apart if the base pin is above or below the motorhome hitch receiver.

If the tow bar is not within the Safe Zone, you must purchase a hitch accessory to raise or lower the hitch

receiver. ROADMASTER has accessories available – Hi-Low Hitches and Dual Hitch Receivers – which will raise or lower the hitch receiver from two to 10 inches, depending on the model.

Towing with the tow bar more than three inches above or below level will void the ROADMASTER warranty.

⚠ WARNING

Failure to follow these instructions may cause property damage, personal injury or even death.

⚠ WARNING

If the motorhome hitch receiver has an extension, do not tow if the tow bar is more than three inches out of level.

Receiver extensions cause the towing system to swing much higher and lower than towing systems without extensions. This enlarged arc of motion creates excessive strain on the tow bar, baseplate and frame, which can cause the towing system to fail, causing property damage, personal injury or even death.

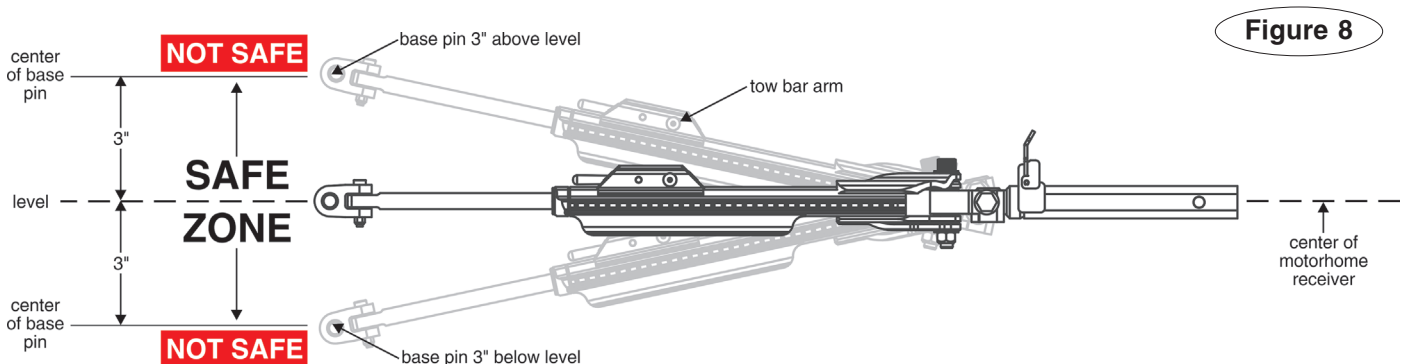
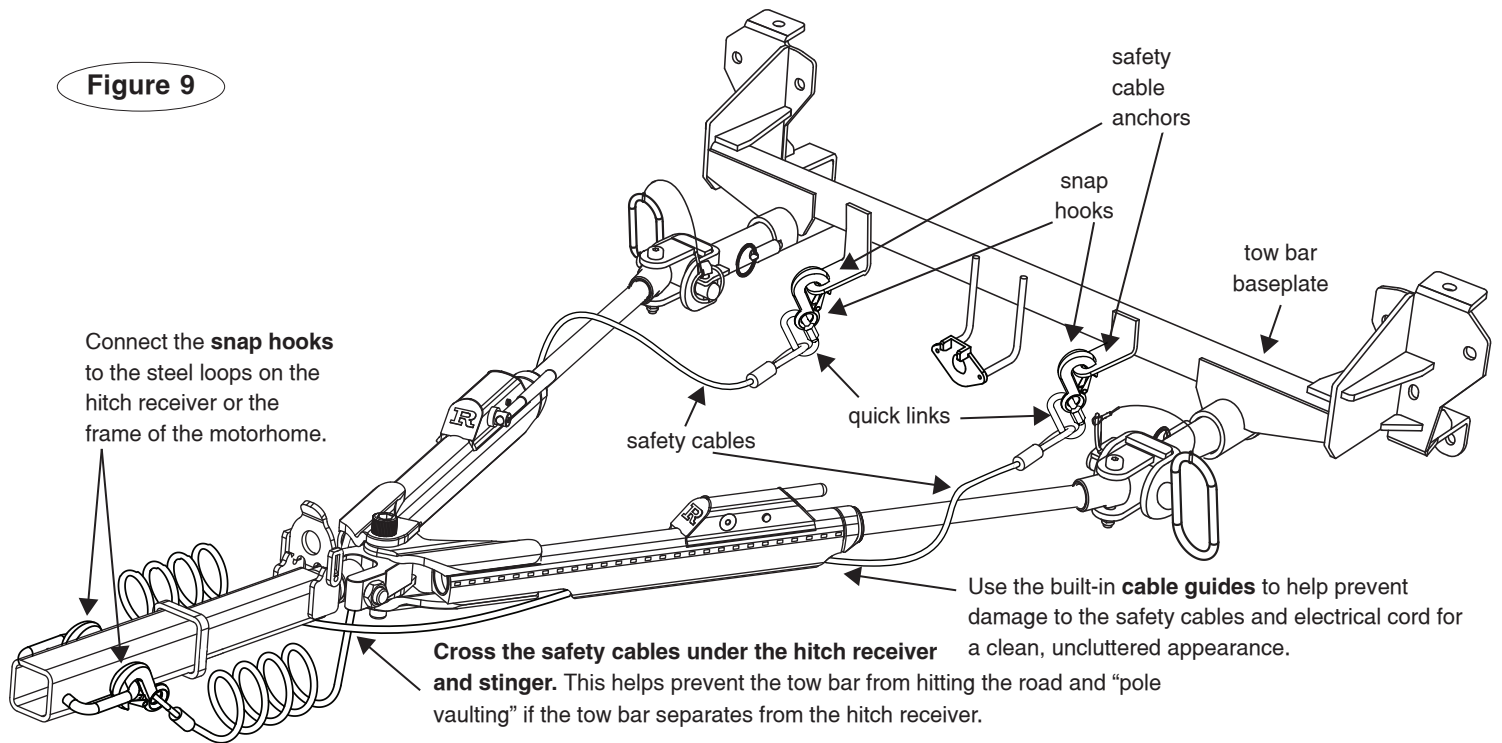

Figure 8

Attaching the safety cables and power cords

Figure 9



Safety cables are an integral part of your towing system. They are a secondary safety device, required by law in many states.

Use the built-in **cable guides** and cross the safety cables under the hitch receiver, as shown above.

Connect the safety cables to the motorhome and towed vehicle as shown in Figure 9.

Do not substitute carabiners or other devices for the quick links – the quick links are designed to hold the weight of a towed vehicle; carabiners are not.

Plug in the **power cords** to the sockets on the motorhome and the towed vehicle. Before each use, test the towed vehicle’s turn signals, tail lights and brake lights to ensure they operate in conjunction with those of the motorhome.

CAUTION

Don’t pull on the power cord when connecting or disconnecting the tow bar, or the LED wiring may be damaged.

⚠ WARNING

The safety cables must be carefully routed so that they cannot become pinched, frayed, scraped or otherwise damaged, and so they will not drag when going over dips or low spots. Do not use the cables if they show any signs of wear or damage – immediately discontinue towing and replace the cables.

Failure to follow these instructions will result in cable failure, which may cause property damage, personal injury or even death.

⚠ WARNING

If the quick links are not completely tightened, with the loop closed, the safety cables may detach. In the event of a towing system failure, the towed vehicle will detach, which may cause property damage, personal injury or even death.

How to use safety cables

- The safety cables must connect the towing vehicle to the towed vehicle, frame to frame.

- **Make sure there is enough slack in the cables to allow for sharp turns** – if there is not enough slack, the towing system will be severely damaged when the motorhome turns a sharp corner.

- Make sure the cables are not too short – if you use a receiver hitch extension or other equipment that extends the distance between the towed vehicle and the motorhome, the standard cables may be too short. If the cables are too short, the towing system will be severely damaged when the motorhome turns a sharp corner.

(Safety cable extensions in a variety of lengths are available from ROADMASTER.)

- Make sure the cables are not too long – the cables should not hang down to the extent they may catch on obstructions, or drag on the ground. This much slack could

cause damage to the towing system, the towed vehicle, or the motorhome.

If the cables are too long, wrap the excess cable around the tow bar to take up the slack. **Make sure there is enough slack in the cables to allow for sharp turns.**

Damage caused by using safety cables of an incorrect length is not covered under warranty.

- Always cross the cables under the hitch receiver, as shown in Figure 9. In the unlikely event the tow bar separates from the motorhome, crossing the cables will help prevent the tow bar from dragging on the ground, which can cause the tow bar to “pole vault” the towed vehicle.

WARNING

Failure to follow these instructions may cause property damage, personal injury or even death.

Care and cleaning

As is the case with most precision equipment, frequent cleaning and care results in better performance and longevity. Use the following guidelines to keep the tow bar arms clean and well-lubricated.

Always clean the tow bar arms before lubricating. Use a water-soluble cleaner such as ROADMASTER Tow Bar Cleaner (part number 9932) – it does an exceptional job of breaking down road film, dirt and grease.

To clean one of the tow bar arms, extend the arm and liberally apply cleaner to the inner arm (Figure 10).

Work the arm in and out to flush out dirt from the inside of the assembly. Wipe the dirt off and repeat until the arm is clean.

Repeat for the other arm.

CAUTION

Do not use petroleum-based products to clean or lubricate the tow bar. Petroleum will attract dirt and dust, which will impede the operation of the sliding arms and/or other components. Certain petroleum products may also corrode non-metallic components.

Damage caused by using a petroleum-based product to clean or lubricate the tow bar is not covered under warranty.

After cleaning the tow bar, wipe any remaining cleaner away.

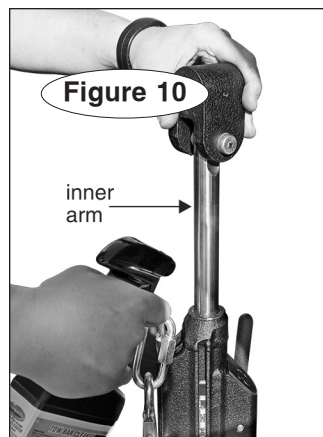

Now that you have a clean, dry tow bar, use a dry silicone lubricant, such as LubeMaster (part number 747), to lubricate the tow bar – spray a liberal amount of the silicone into all moving parts. Flex the tow bar components, to work the lubricant in. LubeMaster sprays on wet, then dries in seconds, so it won't attract dirt or debris.

(Using a silicone lubricant on the base pins will make them easier to pull out, and also creates an oxygen barrier which helps prevent corrosion.)

CAUTION

Always clean the tow bar arms, as described above, before lubricating them. Silicone coats and covers in a thin layer. If it is not removed, it will reduce the clearance, preventing proper operation.

Extended storage – before storing your tow bar for an extended period of time, be sure to clean and lubricate it as above. Store the tow bar in its cover (optional, part number 055-3), to protect it from the elements.

Note: to remove scratches and restore luster on the inner arms, we suggest that you use extra fine (0000) steel wool, 3M “Scotch Brite” (fine pad) or a similar product.

Electrical

LED strips specifications

Lumens..... 300
 Power draw 1 amp

Wiring schematics

Figure 11

front of
6-wire plug

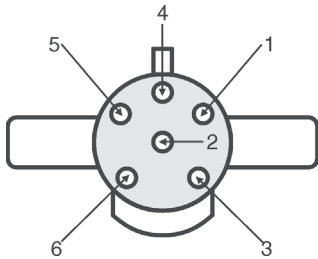

Pin Number	Wire Color	Motorhome/ Towed Vehicle
1	Blue	Brake monitor light (electric trailer brakes)
2	Black	Auxiliary/Charge
3	Green	Right Turn/Stop
4	Brown	Taillights
5	White	Ground
6	Yellow	Left Turn/Stop

Figure 12

front of
7-wire plug

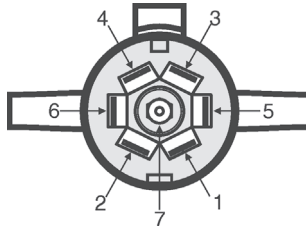

Pin Number	Motorhome/ Towed Vehicle
1	Ground
2	Brake monitor light (electric trailer brakes)
3	Taillights
4	Charge line
5	Left turn/Stop
6	Right turn/Stop
7	Auxiliary/Access

Figure 13

Roadmaster
power cord

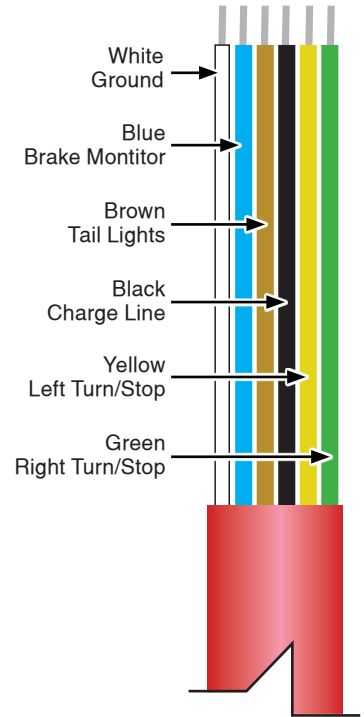

front of
6-wire socket

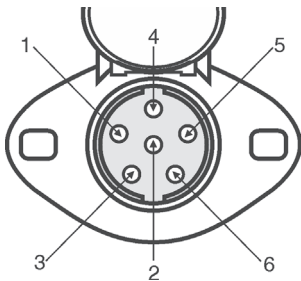

front of
7-wire socket

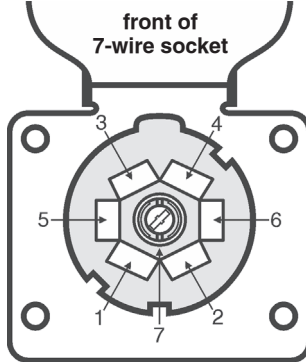

When replacing the power cord...

...be sure to use the original equipment screw, split washer, and clamp (Figure 14). Do not substitute these parts.

WARNING

The screw used to secure the clamp is a very specific length. Any shorter and it won't properly hold the clamp. Any longer and the threads will stick too far inside the tow bar, interfering with internal components.

Use of an incorrect screw, split washer or clamp will damage tow bar components and prevent the tow bar from locking properly, which may cause interference with the inner arm operation, preventing the tow bar from automatically extending, self-centering and locking.

Damage to the tow bar may result, which may cause failure of the towing system and loss of the towed vehicle. Other consequential, non-warranty damage may also occur.

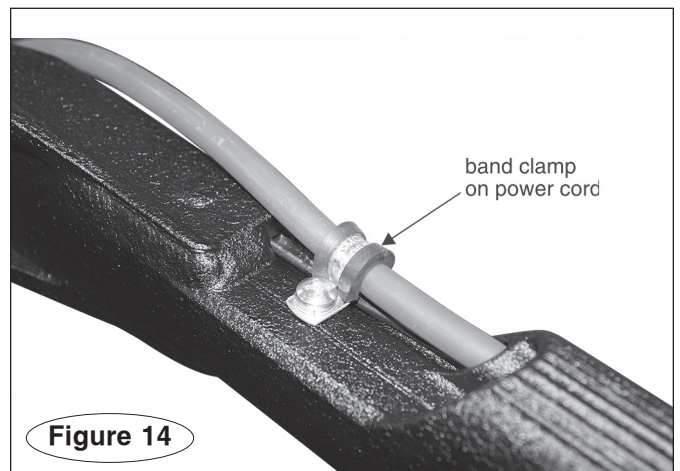
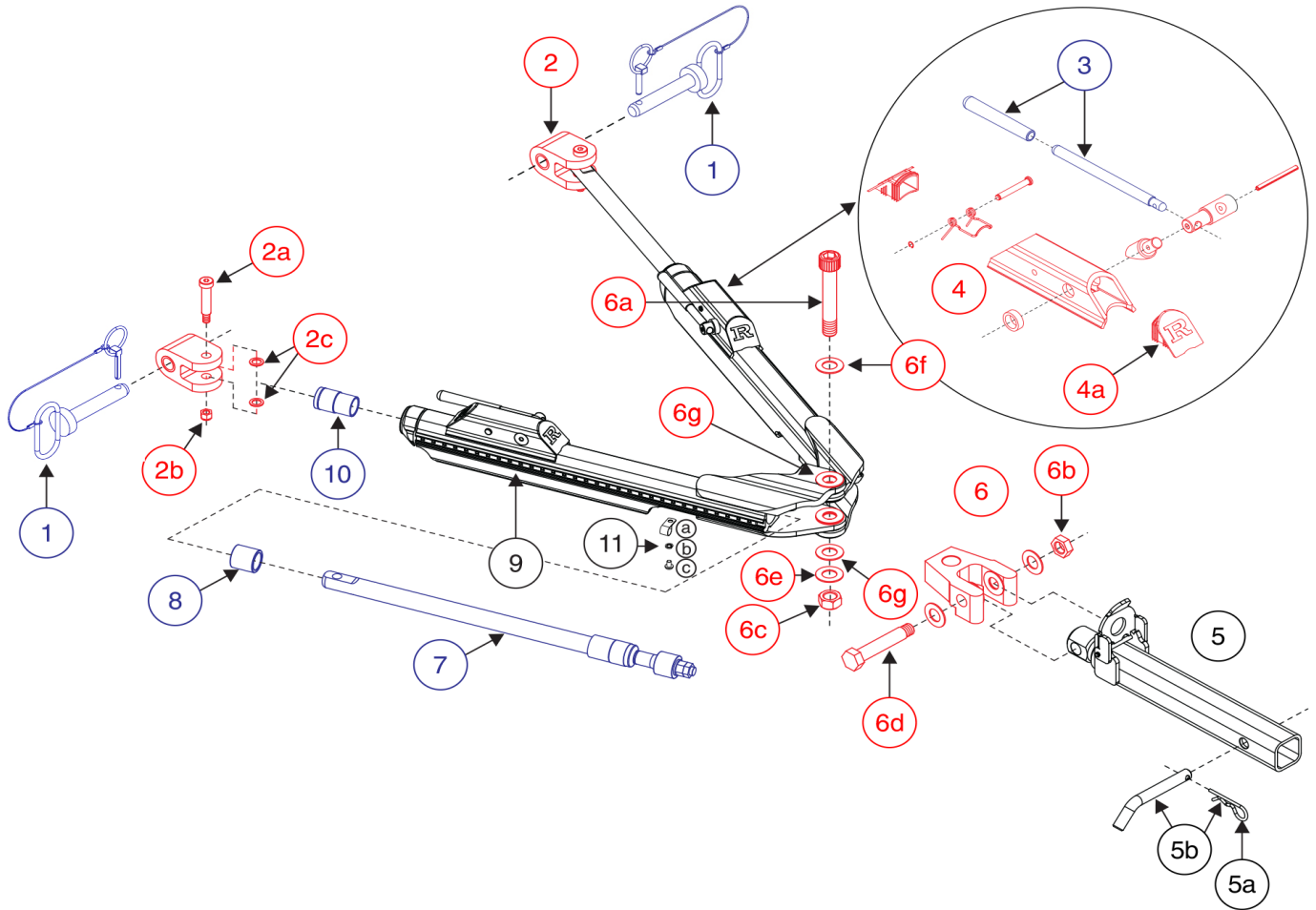

Figure 14

Nighthawk™ parts



<i>description</i>	<i>part number</i>
1 red-handled base pin, cable and linch pin (two each; color-coded blue)	910049
2 swivel ear assembly, one each – includes part numbers 2a, 2b and 2c (color-coded red).....	910661
2a ½" x 2" bolt	350376-00
2b nylon lock nut.....	350255-00
2c ½" nylon washer	350356-00
3 Freedom Latch lock handle and rubber grip (color-coded blue)	750600
4 Freedom Latch spring replacement kit with latch caps – contains four latch caps (part number 4a), and two springs and two snap rings (not shown) – color-coded red.....	910652
4a latch cap only.....	200460-00
5 stinger assembly, complete (color-coded black; part numbers 5a and 5b sold separately)	910520
5a hitch pin clip (two).....	910028
5b hitch pin and clip (one each)	910027
6 yoke	A005380
<i>(part numbers 6a through 6e sold separately)</i>	
6a Qty 1.....¾" x 4¾" bolt	350190-20
6b Qty 1.....¾" jam nut	350264-10
6c Qty 1.....¾" lock nut	350267-01
6d Qty 1.....¾" x 4-1/8" bolt	350191-00
6e Qty 3.....¾" flat washer	350314-60
6f Qty 1.....¾" yellow zinc washer.....	350314-40
6g Qty 13*.....¾" acetal washer	350358-00

<i>description</i>	<i>part number</i>
7 inner arm assembly, driver's and passenger side (color-coded blue)	910660-10
8 Nylatron inner arm spacer	A005406
9 replacement LED light strips kit.....	98676
10 snap-in bushing (color-coded blue).....	A004608
11 replacement power cord bolt and clamp.....	300116-00
11a cord clamp	300116-00
11b split washer	350301-00
11c pan head screw ¼-20 x 3/8"	350003-05

NOT SHOWN

- 6-wire socket only
- 7-wire plug only
- 7- to 6-wire power cord.....
- safety cables:
 - pair
 - each

* not all washers shown in the drawing