



Smart Diode Wiring Kit

for vehicles with incandescent bulbs
part number 153782

856080-06 05.22

All specifications are subject to change without notice.

ROADMASTER, Inc. 6110 NE 127th Ave. Vancouver, WA 98682 800-669-9690 Fax: 360-735-9300 www.roadmasterinc.com

STOP!

If this vehicle has a supplemental braking system installed, read the technical service bulletin at the end of these instructions before this installation. In addition, some late model vehicles have unique wiring peculiarities that may necessitate a different wiring solution. Visit fitmaster.roadmasterinc.com and add your year, make and model to see the suggested wiring solution for your vehicle.



WARNING

Read the instructions before installing the kit components, and wire the towed vehicle according to the instructions and illustrations. Failure to understand how to install this product could result in an electrical malfunction or other collateral or consequential damage.



WARNING

Attach the diodes as close to the towed vehicle's lights as possible, to avoid interaction with other circuits which may be tied into the center brake light, the running lights, the turn signals or the brake light wires.

Attaching the diodes farther away may cause the towed vehicle's lights to work improperly, as well as cause damage to other electrical components in the vehicle.

Parts

- (1) 4-wire wiring harness, 27 feet in length
- (2) white wires, 1 foot in length
- (3) ring terminals
- (2) Smart Diodes for incandescent bulbs
- (1) 10-12 gauge butt connector
- (3) Tek screws
- (1) 3-foot length of split loom
- (11) wire ties

- 3. Attach the Smart Diode as shown in Figure 1. Now, repeat on the opposite taillight assembly.

Step A

Identify the RV's lighting system

1. There are two types – combined or separate. In a **combined** system, the brake light does the flashing for the turn signal; in a **separate** system, there are amber or red turn signal lights which are separate from the brake lights.

If the motorhome has a separate lighting system, a 3-to-2 converter must be installed in order to use this kit. A 3-to-2 converter converts a separate system to a combined system.

Many late-model motorhomes come with converters already installed – test for this before installation: if the motorhome's trailer plug energizes the same pins for both brake lights and turn signals, then a 3-to-2 converter is already installed and the motorhome should be treated as combined.

If a converter is needed, install ROADMASTER's Brite-Lite™, part number 732.

Step B

Wire the towed vehicle for towing

- 1. Expose the wires behind both taillight assemblies. (It may be necessary to remove the taillight assemblies from the exterior of the vehicle to gain access).
- 2. With a circuit tester, identify the circuit in the towed vehicle that will illuminate for towing purposes. For most vehicles, it will be the brake light wire or the taillight wire. These are denoted as car in/car out in Figure 1.

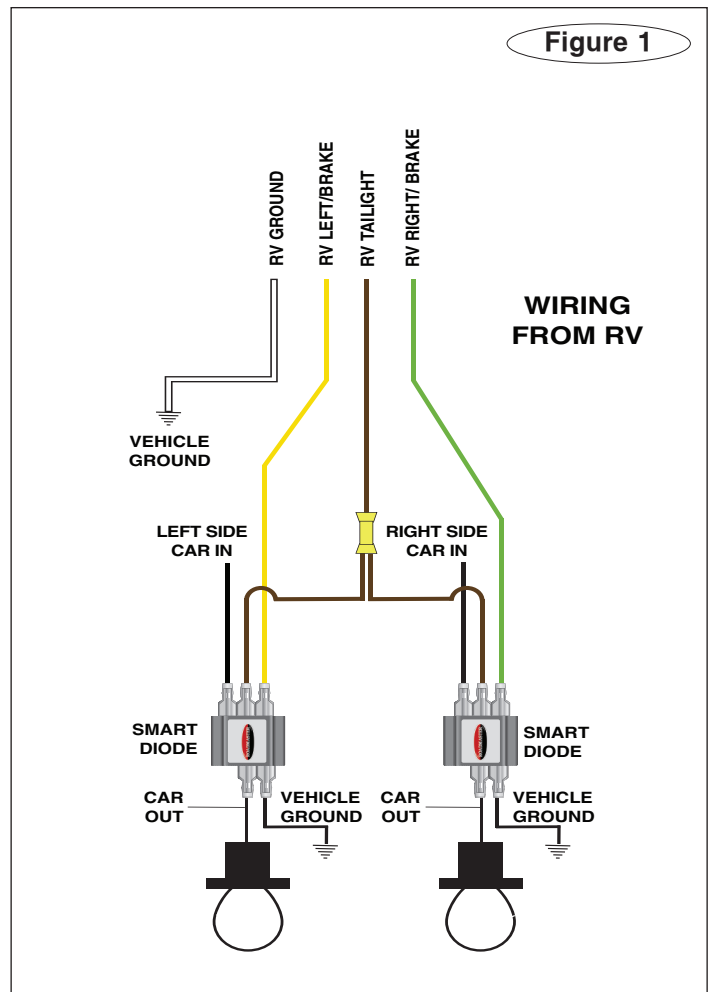

continued from preceding page

4. Now crimp the 12" white wire to the terminal labeled Ground and repeat for the other diode. Use the included ring terminals and Tek screws to ground both wires to the chassis.

Note: To avoid grounding problems, attach the wire to a good chassis ground, preferably directly to the frame.

CAUTION

Refer to the vehicle owner's manual before attaching the ground wire. Some manufacturers may stipulate that ground wires must be attached at specific locations.

Significant damage to the vehicle's electrical system, as well as other consequential, non-warranty damage will occur if the ground wire is not attached at one of these points.

5. Following the schematic, separate the four bonded wires as necessary and connect each wire to the Smart Diodes as shown in Figure 1 (previous page). Use the included yellow butt connector to separate the RV taillight signal to each Smart Diode. Use a ring terminal to ground, as shown in Figure 1.

CAUTION

Failure to attach the diodes as indicated in the wiring diagrams will create a backfeed through the vehicle's electrical system, which will allow electrical current from the towed vehicle to disrupt one or both of the vehicles' electrical systems.

Additionally, if a supplemental braking system is installed it may not operate, or may only operate intermittently.

Step C

Route the wiring harness

1. Carefully route the 4-wire harness to the front of the vehicle. Before you begin, plan a route to the front of the vehicle that avoids the possibility of fraying or melting the wiring against moving parts, sharp edges, the fuel lines or hot components. (If the OEM wiring harness is accessible, consider routing the harness alongside it).



WARNING

Plan a route that will avoid moving parts, sharp edges, the fuel lines or hot components such as the engine or exhaust system.

Wiring exposed by moving parts, sharp edges or hot components may cause a short circuit, which can result in damage to the vehicle's electrical system as well as other, consequential damage.

Wiring which is attached in close proximity to the fuel lines may ignite the fuel.

2. Where appropriate, use a section of the included split loom to protect the wires; use one or more of the included wire ties to secure the wiring in place.

3. If it was necessary to drill a hole, seal it with silicone sealant (not included) after you have routed the harness to the front.

Step D

Attach the wiring harness

1. Attach the end of the 4-wire harness to the electrical socket (not included) at the front of the towed vehicle. Connect the wires according to the instructions that came with the electrical socket.

Step E

Test the system

1. Test each of the circuits to confirm that the lighting functions correctly.

2. Operate the vehicle's brake, turn signals and tail lights to verify the lighting system still functions correctly. *Note: One circuit will now illuminate your brake, turn and taillight for towing purposes only. Note: The vehicle may need to be running to energize the circuits.*

Troubleshooting Section

Symptom: The Smart Diodes are installed properly and there is current going into the Smart Diodes, but there is no current coming out.

Solution: In some vehicles, the lamp-out module stops the flow of current as it can detect the multiple paths to ground and assumes there is a fault. To correct this, disconnect the ground wire on just ONE of the Smart Diodes.

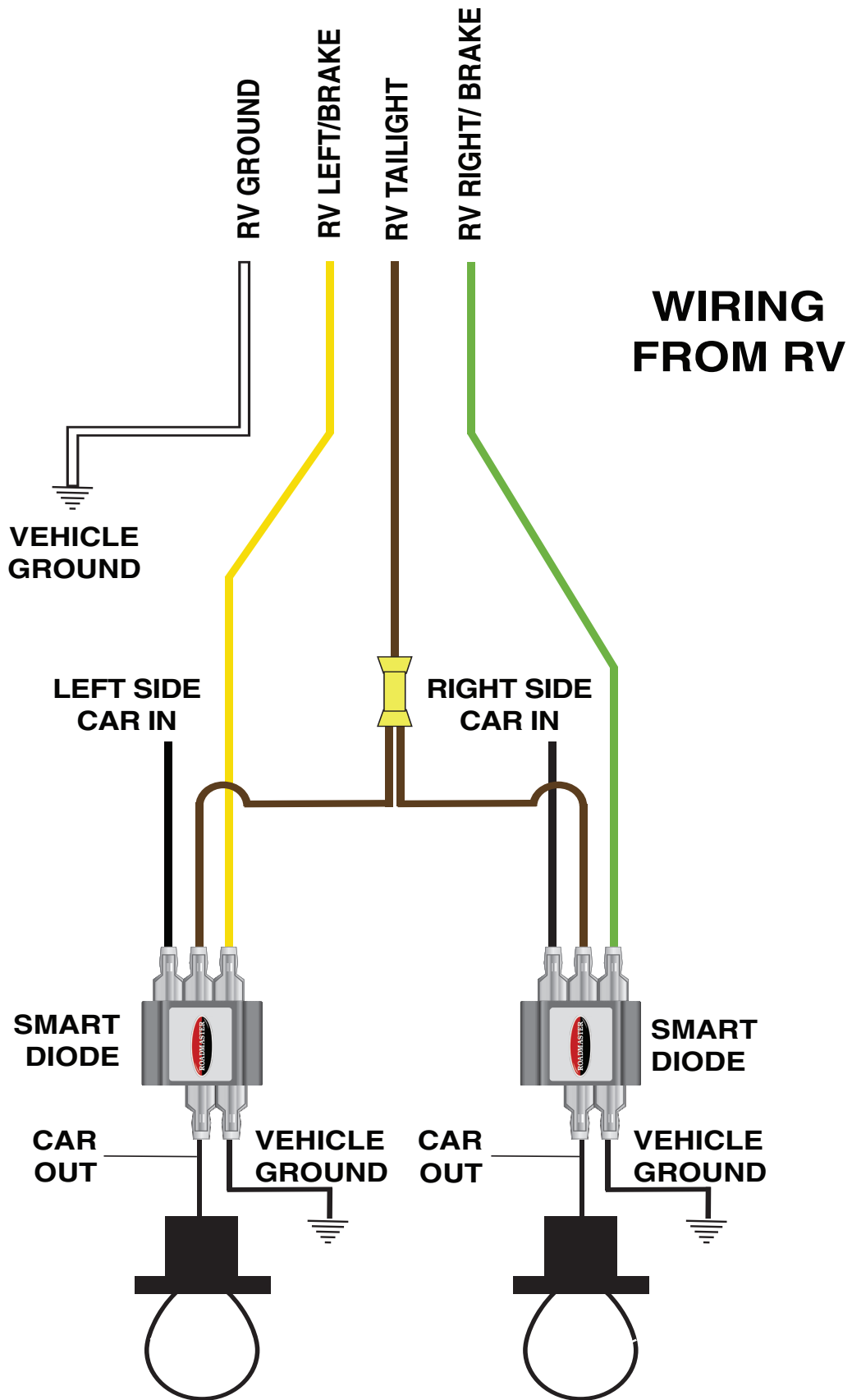



*Technical Service
Information Bulletin
May 11, 2022*

**Subject:
Wiring instructions for vehicles with
brake lights that override turn signals**

TSIB number 155

Problem: You've installed a supplemental braking system in your towed vehicle that makes the car's brake lights illuminate with each braking activity. The brake light cancels the flashing of the turn signal that comes from the RV. Normally, a Brake Light Relay (pn 88400) would solve this problem. But the electronics for the vehicles to which this TSIB applies are too complex and a Brake Light Relay cannot be installed or will not work. Refer to the Fitmaster for vehicles known to experience this issue.

Solution: To fix this issue, use a Smart Diode wiring kit. Use kit 153782 for dinghys with incandescent bulbs, or 153789 for dinghys with LED lights. But wire the diodes using the following schematic. This will allow the taillights to function for the brake, turn and taillights while towing. The lights will still function normally during everyday driving.

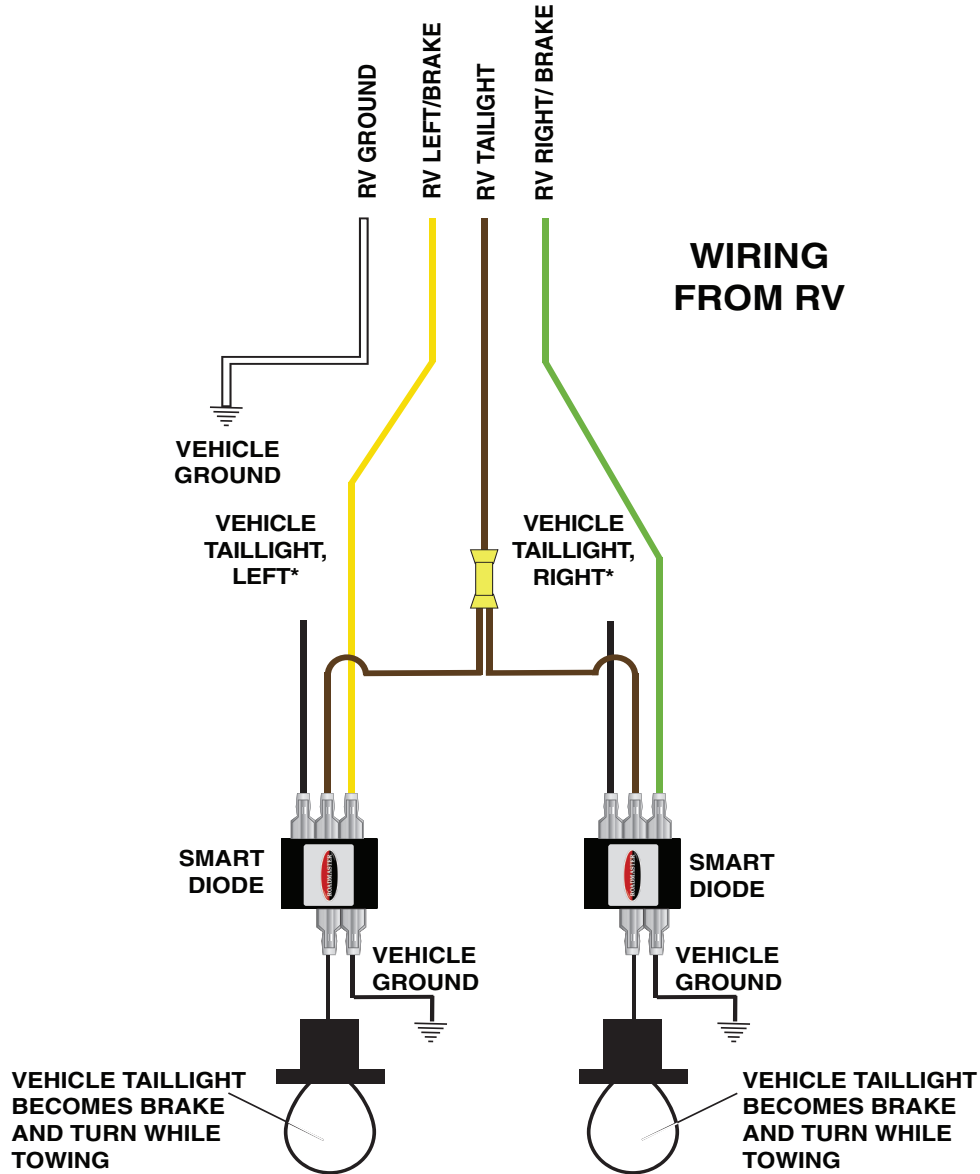

*WIRE COLORS VARY. ALWAYS USE A TEST LIGHT TO ASCERTAIN TAILLIGHT WIRE.