



Installation Instructions

Thank you for purchasing this anti-sway bar kit. Please read through these instructions before installation.

Front Anti-Sway Bar Kit for Ford F600 (Thor Outlaw only)

part #1139-220
1-3/4" diameter



INTRODUCTION

Thank you for purchasing this front anti-sway bar kit. This kit is designed to improve the handling characteristics of your vehicle by reducing the body roll and balancing the weight transfer during cornering. The anti-sway bar kit is engineered for long life and trouble-free performance. All the hardware needed for installation is included in this kit. Refer to the PARTS LIST in these instructions to identify the parts.

SUGGESTED TOOLS

The following tools are suggested to complete the installation procedures:
General Hand Tools

⚠ WARNING

Failure to follow these instructions can result in property damage, personal injury or even death.

- If raising the vehicle to install the anti-sway bar, always support the vehicle with jack stands at both frame rails or at the rear axle before working underneath. Ensure that the jack stands are securely positioned, and are rated at or above the weight of the vehicle.
- The installer must read the instructions and use all bolts and parts supplied. Use only the parts supplied by ROADMASTER to install this kit.
- Minor modifications are sometimes necessary due to slight vehicle variations, even for the same year, make and model.
- Regardless of year, make and model, a wide range of options for specific applications may or may not interfere with the installation. It is the installer's responsibility to make certain that equipment is not damaged once the suspension solution travels through the full range of motion. Failure to ensure adequate clearance could result in non-warranty property damage, personal injury or even death.

- If running changes were made by the manufacturer after this kit was designed, there may be weldments, braces, gussets, or other structural items which interfere with the installation. It is the installer's responsibility to allow for these running changes without sacrificing the structural integrity of the anti-sway bar. Failure to securely fasten the anti-sway bar could result in property damage, personal injury or even death.
- ROADMASTER will not be responsible for any damage or injury resulting from any modification or alteration.
- Check ALL the fasteners for tightness before and after road testing the vehicle.
- Do not use this document for custom fabrication, as it may not show all parts or structural components.
- Do not use an air impact wrench when re-installing bolts, as stripped threads may result.
- This anti-sway bar is only warranted for the original installation. Installing a used anti-sway bar on another vehicle is not recommended and will void the warranty.

PARTS LIST

Part #1139-220

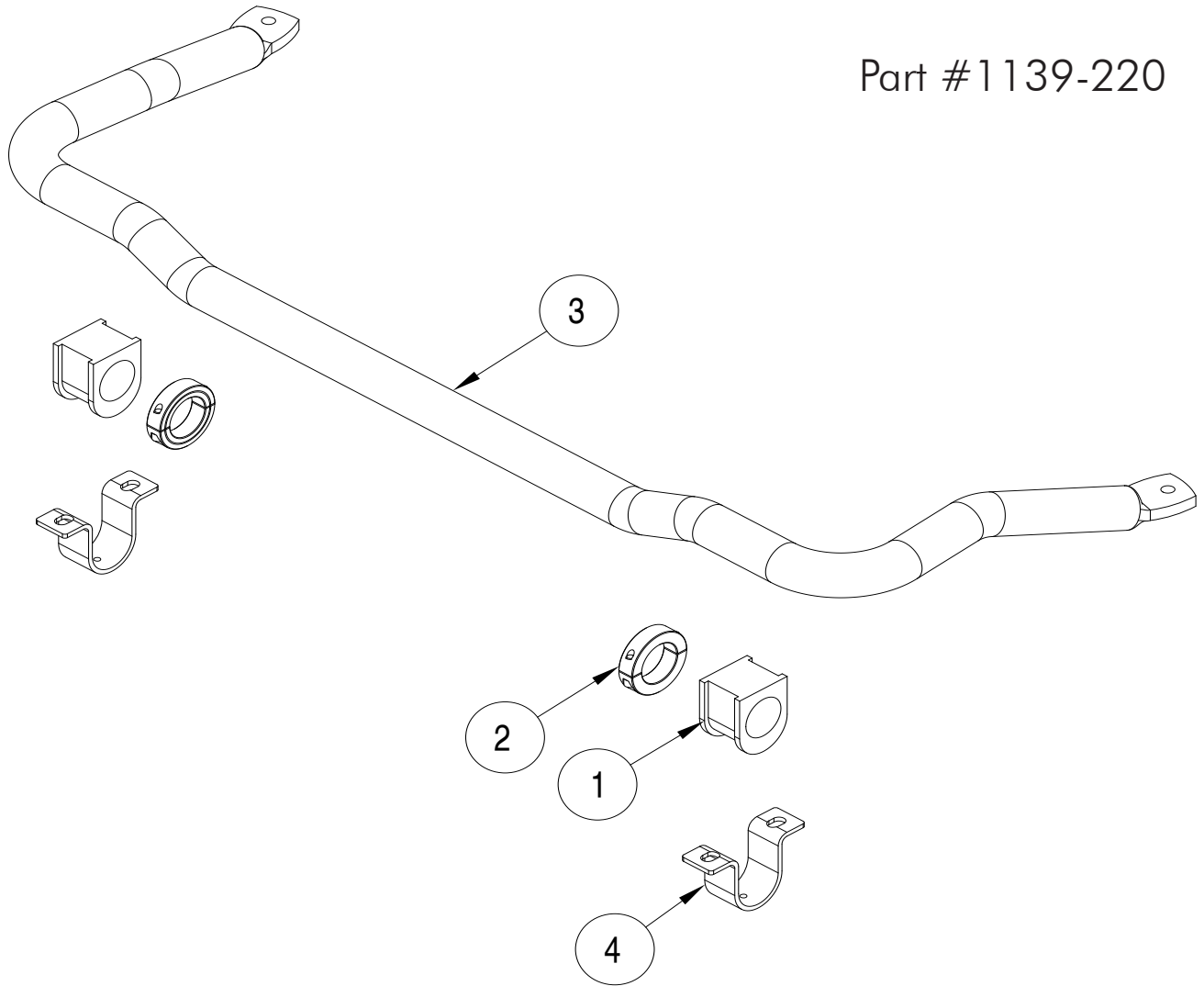

ITEM	QTY	DESCRIPTION	PART NUMBER
1.....	2.....	BUSHING	205220-20
2.....	2.....	SPLIT COLLAR	350530-75
3.....	1.....	ANTI-SWAY BAR.....	580630-00
4.....	2.....	BUSHING CLAMP	B140
5.....	1.....	LOCTITE.....	200544-00
6.....	1.....	AQUALUBE	400011-30

INSTALLATION

The following instructions must be followed in the order listed to ensure a proper installation and to preserve the ROADMASTER warranty.

WARNING

The anti-sway bar is heavy, and may cause property damage or personal injury if it falls on equipment, engine components or any part of your body. Ensure that the anti-sway bar is supported and that you are out of the way when removing the brackets.

Failure to follow these instructions may cause property damage, personal injury or even death.

1. Remove the factory anti-sway bar.

Retain the factory endlink bolts, as they will be used for installation of the new anti-sway bar.

2. Remove the factory bushings and clamps.

Retain the hardware, as it will be used for installation of the new anti-sway bar.

3. Grease the inside of the bushings.

Use the provided Aqualube to grease the inside of the bushings (Figure 1). After greasing, place the bushings over the new sway bar.

4. Install the new sway bar on the factory endlinks.

Place the sway bar over the endlink on each side and, using the factory hardware and Loctite, bolt it into place (Figure 2).

5. Install the new bushings, clamps and set collars.

Bolt the new clamps into place over the bar and bushings using the factory bolts you removed in step 2 (Figure 3). Place Loctite on the bolts and torque them to 53 ft./lbs.

Now, install the split collars to the inside of the bushings as shown in Figure 3 and in the drawing on the previous page.

WARNING

The anti-sway bar is not a load-bearing component

Do not tow or hoist the vehicle using the anti-sway bar or its mounting brackets as attachment points. The anti-sway bar is not designed to carry the weight of the vehicle and may collapse, which will damage the anti-sway bar components, the suspension, or other components. The vehicle will detach or fall, which may cause severe personal injury.

Failure to follow these instructions may result in property damage, personal injury or even death.

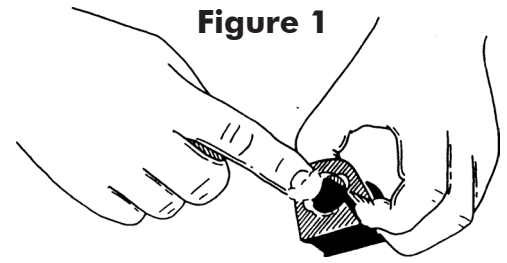

Figure 1

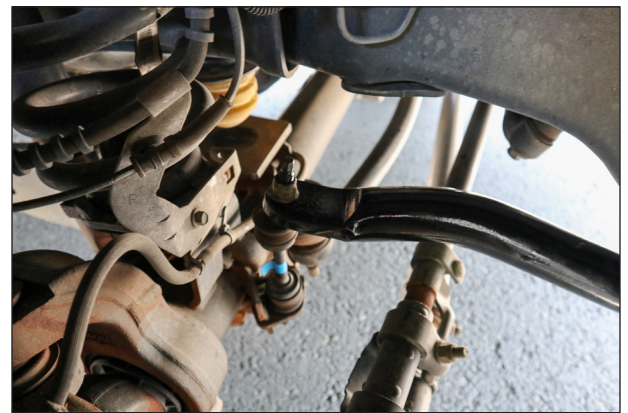

Figure 2



Figure 3