



Time Tested • Time Proven

85-1653-08 07-17

Guardian™  
part number 4000

# Installation Instructions

All specifications are subject to change without notice.

ROADMASTER, Inc. 6110 NE 127th Ave. Vancouver, WA 98682 800-669-9690 Fax: 360-735-9300 www.roadmasterinc.com

## IMPORTANT

The Guardian is designed to help reduce the damage to the vehicle while being towed. Although the Guardian will significantly reduce the amount of vehicle damage, the Guardian will not eliminate all damage. Correspondingly, ROADMASTER expressly disallows any and all claims related to rock chips, dings, scratches or any other damage incurred to the towed vehicle.

## CAUTION

Do not install the Guardian if the vehicle owner's manual prohibits the use of a vertical towing shield of this type. In this instance use a horizontal shield such as the Tow Defender.

## WARNING

Read all instructions before installing the Guardian. Failure to understand how to install the Guardian could result in property damage, personal injury or even death.



## Initial Installation

1. Remove the crossbar (Figure 1) and then the bolts

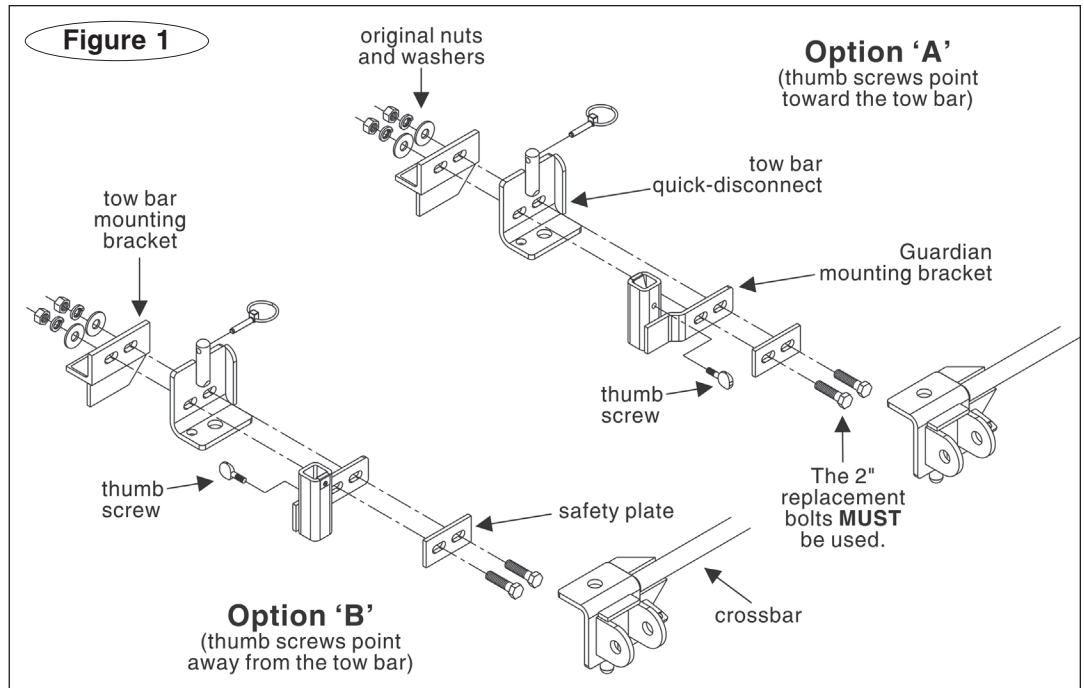

holding the tow bar quick-disconnects (or, "QDs," Figure 1) to the tow bar mounting bracket (Figure 1). Then remove the safety plates (Figure 1) and the tow bar quick-disconnects.

2. There are two ways to attach the Guardian brackets, as shown in Figure 1: 1) Option A (with the thumb screws pointing **toward** the tow bar); or 2) Option B (with the thumb screws pointing **away** from the tow bar).

Use Option A unless the Guardian will be within one inch or less of the towed vehicle – if this is the case, use Option B.

*continued on next page*

## IMPORTANT NOTICE!

### Safety Definitions

These instructions contain information that is very important to know and understand. This information is provided for **safety** and to **prevent equipment problems**. To help recognize this information, observe the following symbols:

## WARNING

WARNING indicates a potentially hazardous situation which, if not avoided, could result in property damage, serious personal injury, or even death.

## CAUTION

CAUTION indicates a potentially hazardous situation which, if not avoided, may result in property damage, or minor or moderate personal injury.

## CAUTION

CAUTION used without the safety alert symbol indicates a potentially hazardous situation which, if not avoided, may result in property damage.

## NOTE

*Refers to important information and is placed in italic type. It is recommended that you take special notice of these items.*

continued from previous page

## CAUTION

The Guardian must not be closer than one inch from the bumper or any other part of the vehicle's body, or permanent damage to the towed vehicle's finish, as well as other consequential, non-warranty damage will occur.

3. Now, reattach the safety plates and the QDs with the Guardian mounting brackets between them, as shown in Figure 1. Use the original nuts and washers. However, do not use the original bolts – use the supplied two-inch replacement bolts (Figure 1).

Do not tighten any of the bolts – leave them loose for now – they will be tightened later.

## ! WARNING

To reassemble the quick-disconnects with the Guardian brackets –

- Use the two-inch replacement bolts – the original bolts are not long enough to compensate for the additional thickness of the Guardian mounting bracket. Unless the bolts thread completely through the nuts, the bolts will pull loose, causing the towed vehicle to separate from the motorhome.
- The safety plates (Figure 1) must be reinstalled. If the safety plates are not reinstalled, metal fatigue can cause a component of the quick-disconnect system to fail, causing the towed vehicle to separate from the motorhome.
- Use all mounting hardware, as shown in Figure 1. If all mounting hardware is not used, the quick-disconnect system will not support the weight of the towed vehicle, resulting in separation of the towed vehicle.

4. The quick-disconnects must be centered on the tow bar mounting brackets (Figure 2). Adjust the quick-disconnects by sliding them to the left or the right, until they are centered over the tow bar mounting brackets.

5. Now, test-fit the crossbar – lower the crossbar over the quick-disconnects (Figure 3). The vertical pins at the top of both quick-disconnects should fit through the top holes at the ends of the crossbar (Figure 2), and the vertical pins at the bottom of the crossbar (Figure 2) should fit through the lower holes on the quick-disconnects.

If necessary, adjust the quick-disconnects again, by moving them to the left or the right, until the crossbar slides on and off easily.

If you must adjust the quick-disconnects a second time, make certain that they are both centered over the tow bar mounting brackets.

6. Next, test-fit the Guardian center panel (Figure 4) – the two posts (Figure 4) at the bottom of the center panel should fit into the Guardian mounting brackets (Figure 4).

If necessary, slide the Guardian mounting brackets to the left or the right, until the center panel slides on and off easily.

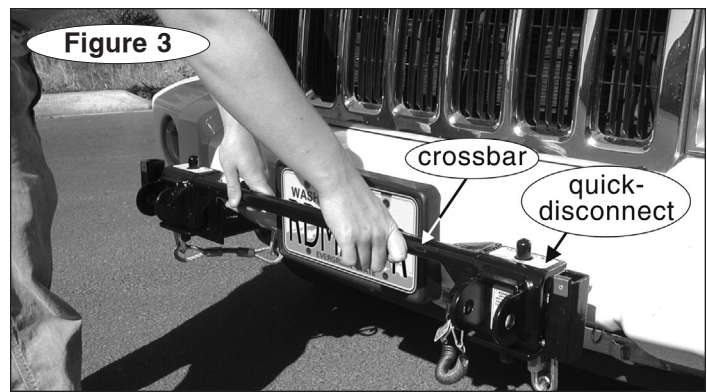
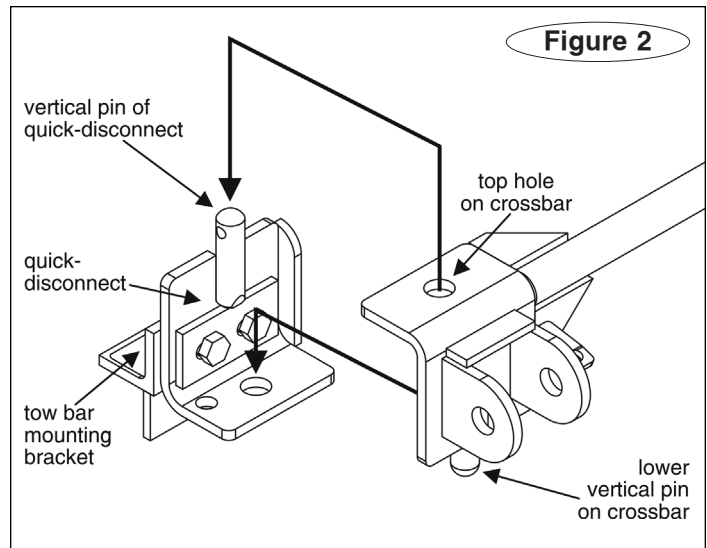

continued on next page

continued from preceding page

### CAUTION

Do not move the tow bar quick-disconnects in order to adjust the Guardian mounting brackets. The tow bar quick-disconnects must be centered on the tow bar mounting brackets. If they are attached too far to the left or the right, the tow bar will not be centered on the towed vehicle, which will cause excessive tire wear and/or other consequential, non-warranty damage.



### WARNING

Be certain that the tow bar brackets and quick-disconnects have been reassembled, according to the installation instructions, before towing. Incorrect assembly will cause the towing system to fail – the towed vehicle will separate from the motorhome.

7. Now, torque the four replacement bolts to 75 ft./lbs. This completes the installation of the Guardian mounting hardware.

## To connect the Guardian for towing...

1. Connect the crossbar between the towed vehicle and the motorhome, according to the instructions in the owner's manual.
2. Fit the two posts at the bottom of the Guardian center panel into the two mounting brackets (Figure 4). Make certain that the posts are completely inserted into the brackets. Attach linch pins (inset, Figure 4) to the bottom of both posts, to secure the posts to the brackets. Tighten the thumb screws (inset, Figure 4).
3. Align both of the side panel tabs to the center panel, and install the connecting rods (Figure 5). Check the thumb screws to confirm they are still tight.



### WARNING

If the thumb screws are not tightened, the Guardian may vibrate loose during towing, which can cause property damage, personal injury or even death.

4. To disconnect the Guardian, reverse steps 1 through 3.

## To store the Guardian...

Remove the side panels, rotate them 180 degrees, and reattach them behind the center panel.

*Note: The optional Stowaway (part number 4000-10) or the Stowaway with rear RV access (part number 4000-40) will store the Guardian on the back of the motorhome.*

## Cleaning the Guardian

1. Wipe the entire surface with a silicone protectant. Apply the protectant when the temperature is between 60 and 100 degrees Fahrenheit.
2. To remove bugs or road dirt, clean with Voom™ RV (part number 9911, 32 ounce spray) and a light scrub. Rinse with water, then apply a silicone protectant.
3. Wire brushes, acids, flame or heat will damage the

Guardian. Solvents will damage the Guardian logo.

### CAUTION

Keep the Guardian away from direct heat sources, such as exhaust systems or furnace vents – the plastic will melt.

### CAUTION

Do not drive the towed vehicle with the Guardian in place. The engine will overheat, which can cause severe damage to the engine.

