

Installation Instructions for the 4000-40 Stowaway with rear RV access

Use the following instructions to install the 4000-40 Stowaway. Installation instructions for the 4000-10 Stowaway are on the reverse.

Before you begin...

In order to install the Stowaway, the motorhome receiver must extend past the rear of the coach. If the receiver is recessed, it can be extended an additional 12 inches with optional receiver extension #071, or six inches with optional receiver extension #072.

These extensions will work with any ROADMASTER motorhome-mounted tow bar.

Installation Instructions

(Refer to Figure A)

- For car-mounted tow bars – Slide the collar of the Stowaway over the motorhome ball mount. Then, insert the ball mount into the motorhome receiver, and attach the ball mount to the receiver.
 For motorhome-mounted tow bars – Slide the collar of the Stowaway over the tow bar stinger. Then, insert the stinger into the motorhome receiver, and attach the stinger to the receiver.
- Now, slide the pin through the holes in the collar, and insert the clip through the pin to secure the Stowaway. Use the thumb screw to tighten the connection. (After the Stowaway is installed, it may be removed or attached without taking the tow bar off – simply loosen the thumb screw, and then remove or attach the pin and clip.)
- Attach the remaining hardware as shown in Figure A; finger-tighten only.
- Test-fit the Guardian over the brackets and adjust the spacing, if necessary, to accommodate the Guardian. Then, tighten all bolts.
- The Stowaway can be left on the ball mount (or tow bar stinger) while towing; however, never use the Stowaway as a mounting platform to tow a vehicle.

WARNING

Do not use the Stowaway or its mounting brackets as attachment points to tow a vehicle. The Stowaway is not designed to carry the weight of a vehicle and will fail if used for towing, which will cause the vehicle to detach, resulting in property damage, personal injury or even death.

- When not towing, store the Guardian on the Stowaway by lowering the Guardian onto the brackets. Then, secure it in place by attaching the linch pins (that came with the Guardian) through the holes at the bottom of the square tubes.

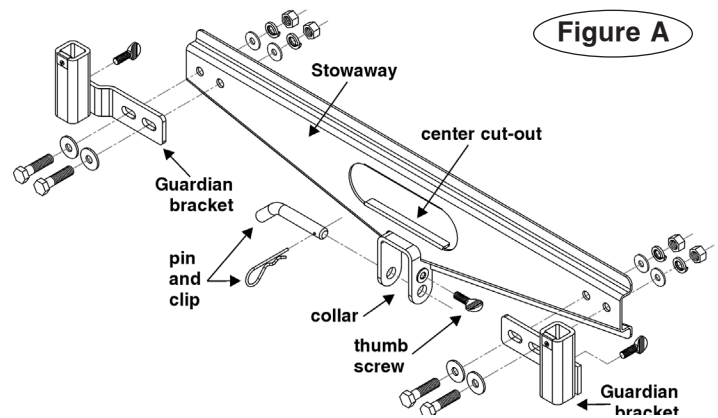

Figure A

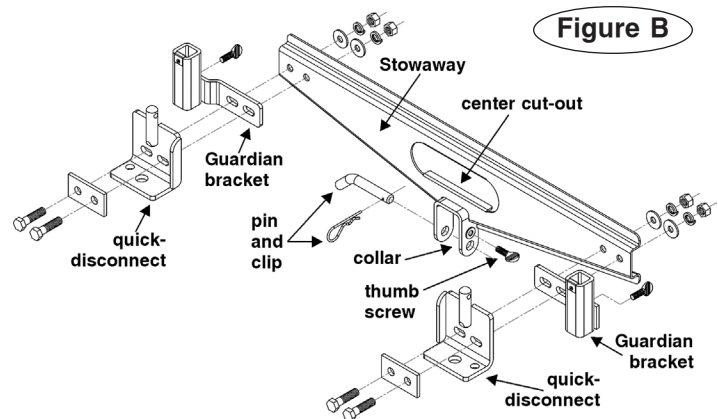

Figure B

CAUTION

Make certain that the Stowaway, or anything stored on the Stowaway, does not come into contact with the motorhome. If the Stowaway vibrates against the motorhome, it may damage the finish, or cause other non-warranty damage.

Also, ensure that the Guardian is not too close, or comes into contact with, the motor-home exhaust (or any other “hot” component) when it is stored on the Stowaway. The heat from the exhaust may deform the Guardian.

- If convenient, the motorhome-to-towed vehicle electrical connections can be routed through the center cut-out.

Additional Storage Option

(Refer to Figure B)

In addition to the Guardian, the Stowaway 4000-40 will also store either a StowMaster tow bar, or any ROADMASTER quick-disconnect base, with the addition of an optional set of quick-disconnects (part number 222). Simply bolt the quick-disconnects on, in conjunction with the Guardian brackets, as shown in Figure B.

Installation Instructions for the 4000-10 Stowaway

Use the following instructions to install the 4000-10 Stowaway. Installation instructions for the 4000-40 Stowaway are on the reverse.

Before you begin...

In order to install the Stowaway, the motorhome receiver must extend past the rear of the coach. If the receiver is recessed, it can be extended an additional 12 inches with optional receiver extension #071, or six inches with optional receiver extension #072.

These extensions will work with any ROADMASTER motorhome-mounted tow bar.

Installation Instructions

(Refer to Figure 1)

1. For car-mounted tow bars – Slide the collar of the Stowaway over the motorhome ball mount. Then, insert the ball mount into the motorhome receiver, and attach the ball mount to the receiver.
 For motorhome-mounted tow bars – Slide the collar of the Stowaway over the tow bar stinger. Then, insert the stinger into the motorhome receiver, and attach the stinger to the receiver.
2. Now, tighten the set bolts to secure the Stowaway.
3. Attach the remaining hardware as shown in Figure 1; finger-tighten only.
4. Test-fit the Guardian over the brackets and adjust the spacing, if necessary, to accommodate the Guardian. Then, tighten all bolts.
5. The Stowaway can be left on the ball mount (or tow bar stinger) while towing; however, never use the Stowaway as a mounting platform to tow a vehicle.

WARNING

Do not use the Stowaway or its mounting brackets as attachment points to tow a vehicle. The Stowaway is not designed to carry the weight of a vehicle and will fail if used for towing, which will cause the vehicle to detach, resulting in property damage, personal injury or even death.

6. When not towing, store the Guardian on the Stowaway by lowering the Guardian onto the brackets. Then, secure it in place by attaching the linch pins (that came with the Guardian) through the holes at the bottom of the square tubes.

CAUTION

Make certain that the Stowaway, or anything stored on the Stowaway, does not come into contact with the motorhome. If the Stowaway vibrates against the motorhome, it may damage the finish, or cause other non-warranty damage.

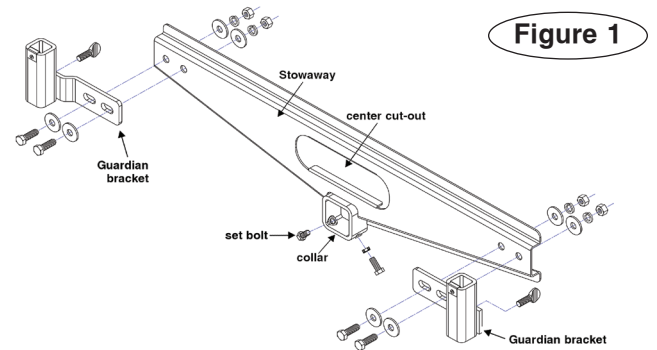

Figure 1

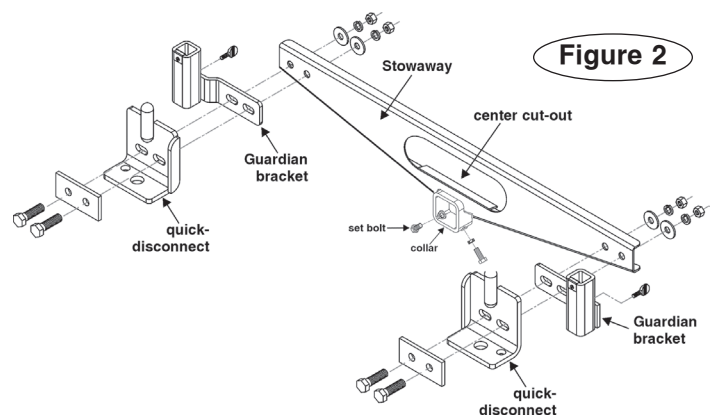

Figure 2

CAUTION

Ensure that the Guardian is not too close, or comes into contact with, the motorhome exhaust (or any other “hot” component) when it is stored on the Stowaway. The heat from the exhaust may deform the Guardian.

7. If convenient, the motorhome-to-towed vehicle electrical connections can be routed through the center cut-out.

Additional Storage Option

(Refer to Figure 2)

In addition to the Guardian, the Stowaway 4000-10 will also store either a StowMaster tow bar, or any ROADMASTER quick-disconnect base, with the addition of an optional set of quick-disconnects (part number 222).

Simply bolt the quick-disconnects on, in conjunction with the Guardian brackets, as shown in Figure 2.

