



Installation Instructions

Thank you for purchasing this anti-sway bar kit. Please read through these instructions before installation.

Front Anti-Sway Bar Kit for Monaco Diplomat (2005 to 2008)

part #1169-110

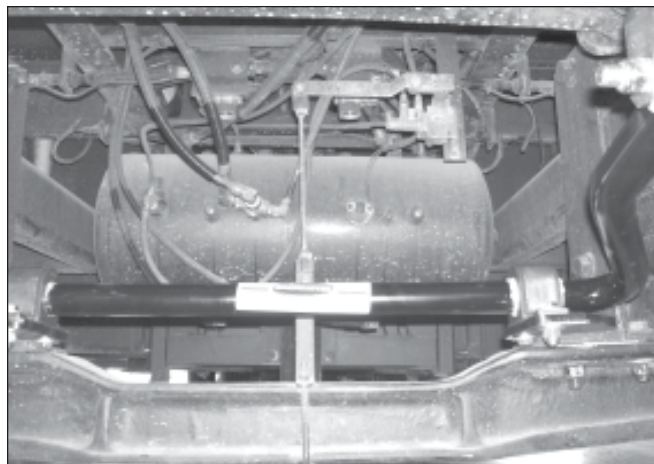

INTRODUCTION

Thank you for purchasing this anti-sway bar kit. This kit is designed to improve the handling characteristics of your motorhome by reducing the body roll and balancing the weight transfer during cornering. The anti-sway bar kit is engineered for long life and trouble-free performance. For maximum suspension control, use this kit along with our rear anti-sway bar kit.

All the hardware needed for installation is included in this kit. Refer to the PARTS LIST in these instructions to identify the parts.

SUGGESTED TOOLS

The following tools are suggested to complete the installation procedures:

- General hand tools
- Torque wrench

WARNING

- If raising the vehicle to install the anti-sway bar, always support the vehicle with jack stands at both frame rails or at the rear axle before working underneath. Ensure that the jack stands are securely positioned, and are rated at or above the weight of the vehicle.
- The installer must read the instructions and use all bolts and parts supplied. Use only the parts supplied by ROADMASTER to install this kit.
- Minor modifications are sometimes necessary due to slight vehicle variations, even for the same year, make and model.
- If running changes were made by the manufacturer after this kit was designed, there may be weldments, braces, gussets, or other structural items which interfere with the installation. It is the installer's responsibility to allow for these running changes without sacrificing the structural integrity of the anti-sway bar. Failure to securely fasten the anti-sway bar could result in property damage, personal injury or even death.
- ROADMASTER will not be responsible for any damage or injury resulting from any modification or alteration.
- Check ALL the fasteners for tightness before and after road testing the vehicle.
- Do not use this document for custom fabrication, as it may not show all parts or structural components.
- Do not use an air impact wrench when re-installing bolts, as stripped threads may result.
- This anti-sway bar is only warranted for the original installation. Installing a used anti-sway bar on another vehicle is not recommended and will void the warranty.

WARNING

Failure to follow these instructions can result in property damage, personal injury or even death.

PARTS LIST

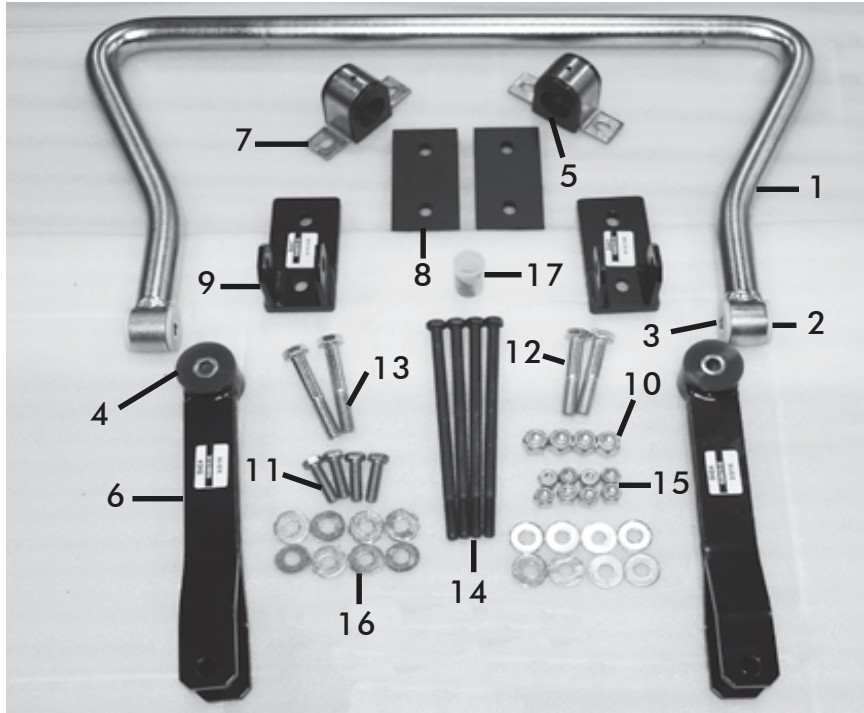

Part #1169-110

Part #	Description	Qty		Part #	Description	Qty
1.	580164-00 Front anti-sway bar, 1-5/8"	1	*	11.	350096-80 Bolt NC, 1/2" x 1-3/4"	2
2.	205209-00 Poly bushing	4	*	12.	350163-00 Bolt, 5/8" x 3-1/2"	2
3.	205503-00 Sleeve	4		13.	350158-00 Bolt, 5/8" x 4"	2
4.	205202-10 Poly bushing	4		14.	357461-00 Bolt, 1/2" x 9-1/2"	4
5.	205222-10 Poly bushing, 1-5/8" split	2		15.	350259-00 Nyloc nut, 1/2"	8
6.	B404 Shackle, 12-5/8"	2		16.	350308-00 Washer, 1/2"	16
7.	B141 U-damp bracket	2		17.	400011-30 AQUALUBE Grease	1
8.	B460 Bracket, 6"x3"x1/2"	2		18.	*B534 Axle Bracket, 10-1/4 x 3"x1/2"	2
9.	B461 Bracket with tabs	2		19.	*350274-80 Bolt, 3/4" x 3-1/2"	4
10.	350263-00 Nyloc Nut 5/8"	4				

* not shown

INSTALLATION

The following instructions must be followed in the order listed to ensure a proper installation and to preserve the ROADMASTER warranty.

1. Install the axle brackets.

Begin by removing the two inside axle bolts that attach the H-frame to the axle on each side. Now, install the B534 bracket using the longer bolts provided in the kit (Figure 1).

Now, only install the front bolt at this time. Do not tighten. The tab of the bracket goes toward the front of the chassis. With the bracket facing the front of the coach, install both axle bolts. *Note:* install the rear bushing clamp bolt from underneath before tightening the axle bolts.

2. Prepare the anti-sway bar for installation.

Locate the D shaped sway bar bushings. Lubricate the inside with the supplied grease. Install the bushings onto the anti-sway bar. Now, slip the B141 bushing clamp onto the bushings (Figure 2). *Note:* tighten the axle bracket bolts and anti-sway bar bushing clamp bolts.

3. Install the shackle frame brackets.

Locate the frame cross member above the front of the H-frame (Figure 3). The B460 flat plate sits on top of the cross member and is connected to the B461 shackle bracket by the long bolts. The tabs on the bracket face down and towards the back of the chassis. Loosely assemble and slide the brackets as far outward as possible, then tighten.

4. Attach the shackles to frame brackets

Using the provided F351 bolts (3-1/2" long) hang the shackles from the frame brackets (Figure 4).

5. Attach the sway bar to shackle

Using the provided F352 bolts (4" long) connect the shackles to the anti-sway bar (Figure 4).

6. Recheck all the fasteners and then test drive.

Listen for any unusual noises.

7. Recheck all the fasteners after test driving.

WARNING

After road testing, re-check all fasteners for proper tightness — if a fastener has worked loose or fallen off, re-tighten or replace it. Without all kit components properly tightened or in place, the anti-sway bar will not stabilize the vehicle at full capacity, which may cause reduced cornering ability or other reductions in vehicle handling or performance.

Failure to follow these instructions may result in property damage, personal injury or even death.

WARNING

The anti-sway bar is not a load-bearing component

Do not tow or hoist the vehicle using the anti-sway bar or its mounting brackets as attachment points. The anti-sway bar is not designed to carry the weight of the vehicle and may collapse, which will damage the anti-sway bar components, the suspension, or other components. The vehicle will detach or fall, which may cause severe personal injury.

Failure to follow these instructions may result in property damage, personal injury or even death.

INSTALLATION

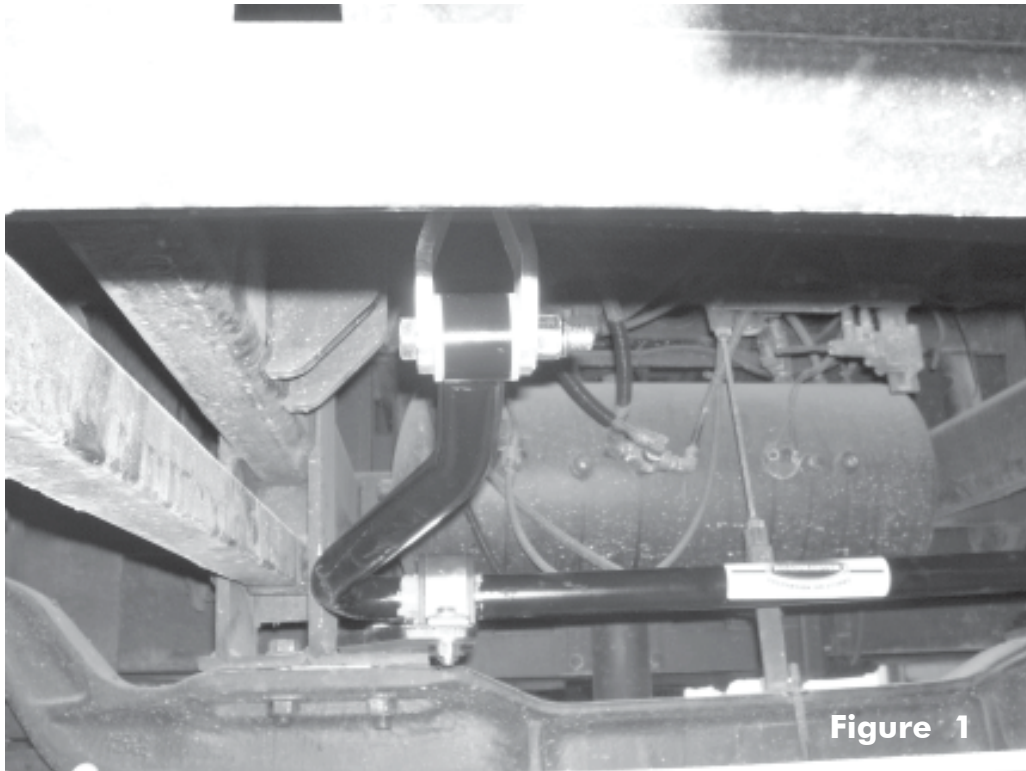
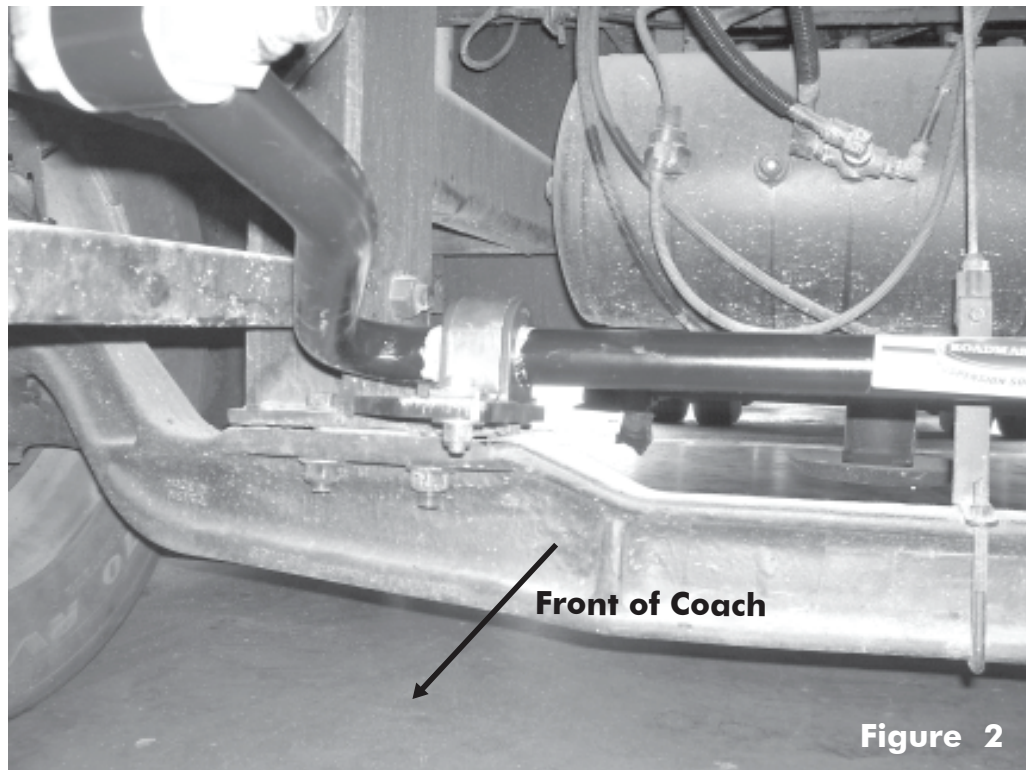

Figure 1



Front of Coach

Figure 2

INSTALLATION

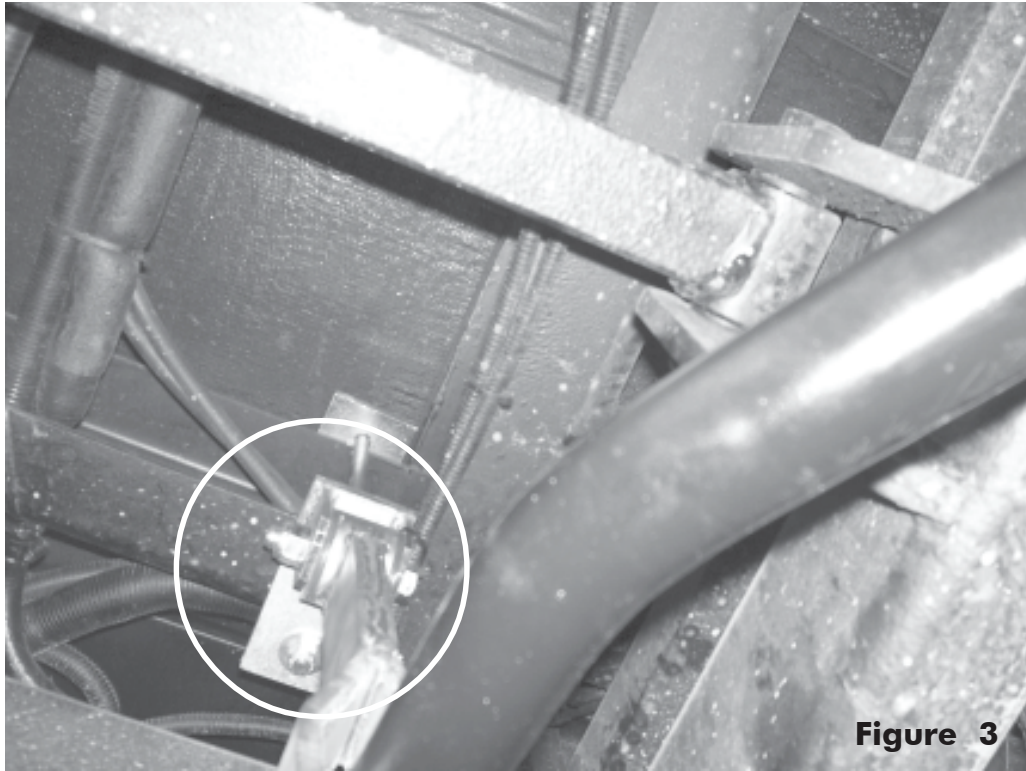

Figure 3

← **Front of Coach**

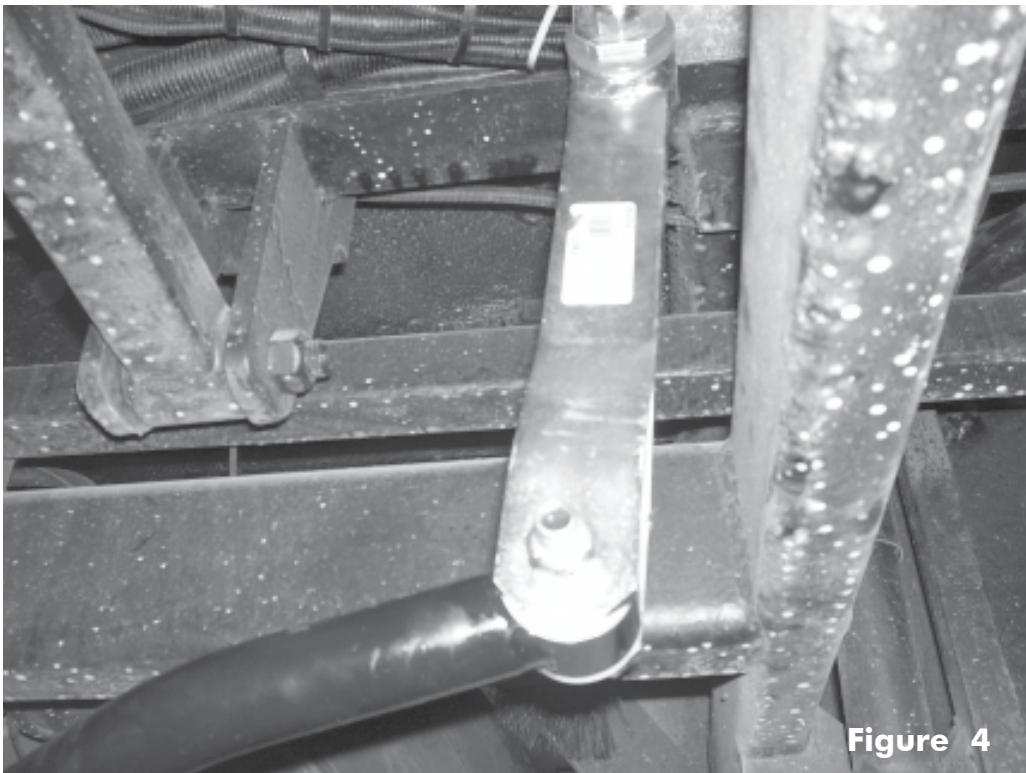

Figure 4

Front of Coach →