



BASEPLATE KIT INSTALLATION INSTRUCTIONS

KIT# 1170-6

02/25/21
KS

ROADMASTER, Inc. 6110 NE 127th Ave. Vancouver, WA 98682 360-896-0407 fax 360-735-9300 www.roadmasterinc.com

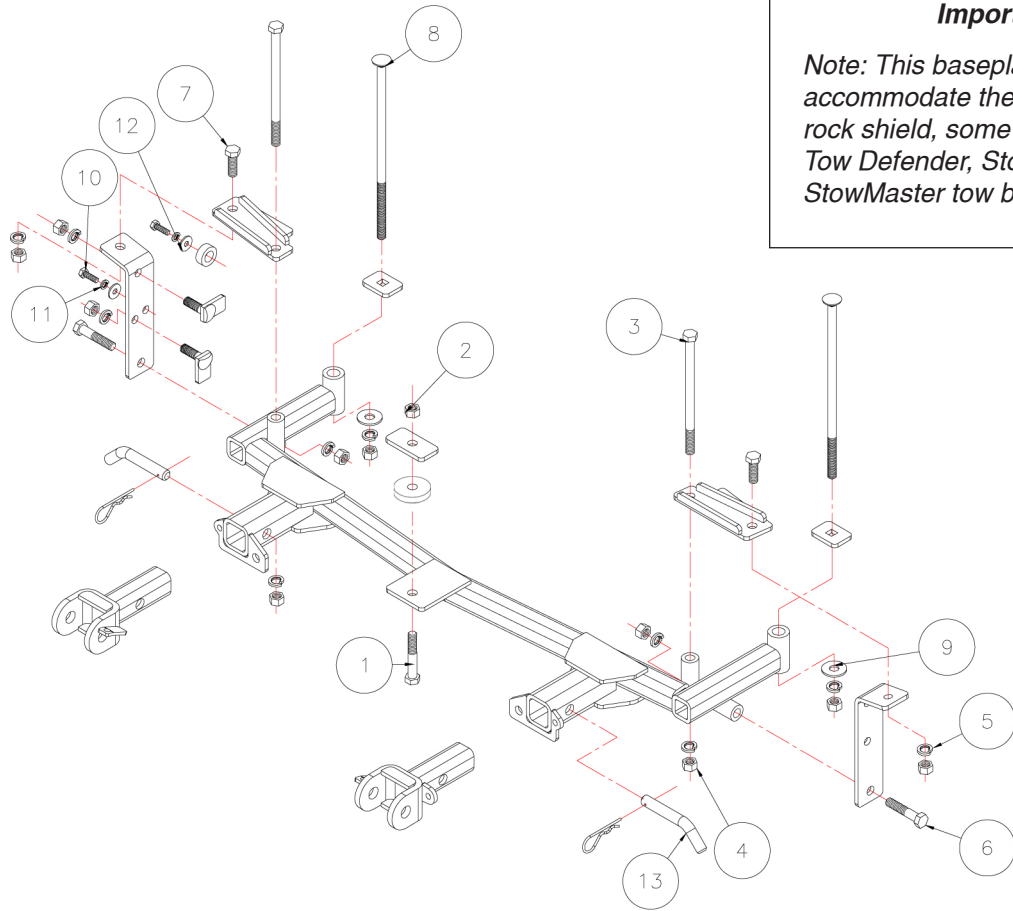

Important
Note: This baseplate will not accommodate the Guardian rock shield, some models of the Tow Defender, Stowaway or any StowMaster tow bars.

Item	Qty	Length	Width	Hardware	Part No.
1	1	3"	1/2"	BOLT	350101-00
2	1		1/2"	2-WAY LOCK NUT	350258-20
3	2	8"	1/2"	BOLT	350113-00
4	10		1/2"	NUT	350258-00
5	10		1/2"	LOCK WASHER	350309-00
6	2	2 1/2"	1/2"	BOLT	350099-00
7	2	1 1/2"	1/2"	BOLT	350095-00
8	2	9"	1/2"	CARRIAGE BOLT	350117-00
9	2		1/2"	FLAT WASHER	350308-20
10	2	25mm	6mm	6mm x 1.0 x 25mm	355894-00
11	2		6mm	LOCK WASHER	355761-00
12	2		6mm	FENDER WASHER	355755-00
13	2			DRAW PIN/SPRING PIN	357035-00



BASEPLATE KIT INSTALLATION INSTRUCTIONS

KIT# 1170-6

02/25/21
KS

ROADMASTER, Inc. 6110 NE 127th Ave. Vancouver, WA 98682 360-896-0407 fax 360-735-9300 www.roadmasterinc.com

Item	Qty	Part No.	Assembly
1	1	C001516	MAIN RECEIVER BRACE WELDMENT
2	1	C000699	DRIVER SIDE BACKING PLATE WELDMENT
3	1	C000700	PASSENGER SIDE BACKING PLATE WELDMENT
4	1	A006137	1/2" SPACER PLATE
5	1	A000185	1 1/2" X 3" BACKING PLATE
6	2	A000039	1 1/2" X 2" SQ. HOLE BACKING PLATE
7	1	A000187	1" O.D. x 3/8" x .188 WALL TUBE
8	1	C000932	PASSENGER SIDE SIDE MOUNTING PLATE
9	1	C000931	DRIVER SIDE SIDE MOUNTING PLATE
10	1	C000933	DRIVER SIDE ARM BRACE WELDMENT
11	1	C000934	PASSENGER SIDE ARM BRACE WELDMENT
12	2	C000944	THREADED BACKING PLATE

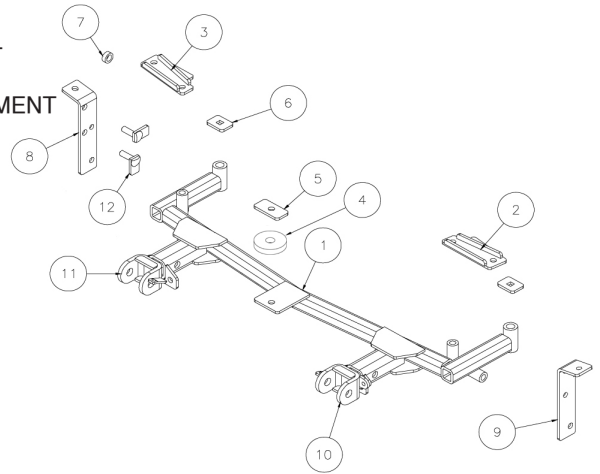

IMPORTANT: All baseplates **must** be assembled with all the bolts left loose for final adjustment and positioning (before tightening) unless otherwise instructed. All bolts **must** be torqued for proper strength. If more than one bolt is used per fastening point, the diagram may only show one. Use flat washers over all slotted holes and lock washers on all fasteners.

WARNING

Failure to heed these warnings or follow the installation instructions may result in a voided warranty, loss of towed vehicle, personal injury or death.

- Do not weld or modify this baseplate or its components. Welding or modification will void the warranty.
- Do not use this document as a basis to design/fabricate a baseplate, as it may not show all parts or structural components.
- We strongly recommend professional installation.
- If the towed vehicle has been in an accident, it must be properly repaired before attaching the baseplate. Do not install the baseplate if any structural frame damage is found.
- The installer must use all bolts and parts supplied. If running changes were made by the vehicle manufacturer after this kit was designed, some bolts or other fasteners may no longer be the correct size. It is the installer's responsibility to verify this kit is securely fastened to the vehicle.
- Use Loctite® Red on all bolts used to secure this baseplate. Torque all bolts to the specifications found at the end of these instructions. Do not over-torque the bolts or failure may occur.
- The installer must inspect the baseplate to ensure adequate clearance, particularly around hoses, air conditioner lines, radiators, etc. or non-warranty failure may result.
- Roadmaster manufactures many styles of baseplates. If your baseplate has removable arms, they must be removed before driving the vehicle, unless the arms can be pinned or padlocked in place. If not secured, the arms could vibrate out.
- Some motorhome chassis have such a tight turning radius that you can damage your motorhome, towed vehicle, tow bar or baseplate while turning sharply. Before getting on the road, test your turning radius in an empty parking lot. Turning too sharply could

result in non-warranty damage to your towing system, motorhome and/or towed vehicle.

- Do not back up with the towed vehicle attached or non-warranty damage will occur to your towing system or vehicles.
- The safety cables must connect the towing vehicle to the towed vehicle frame to frame, with the cables crossed, with enough slack for sharp turns. See cable instructions for proper routing. Failure to do so will result in non-warranty damage and/or the loss of the towed vehicle.
- This kit is designed for use with ROADMASTER tow bars and ROADMASTER adapters only. Using this kit with other brands, without an approved ROADMASTER adapter, may result in non-warranty damage or injury.
- Receiver extensions and out-of-level towing situations of 3 inches or more. This can cause the system to swing much higher and lower, causing excessive strain on the tow bar, baseplate and frame. That can cause the towing system to fail, causing property damage, personal injury or even death. If you must use a receiver extension or drop hitch to tow, it will reduce your receiver's weight capacity by 1/3 to avoid damaging your system. Never use more than one extension and/or drop hitch, as this will void your warranty.
- Every 3,000 miles, the owner must inspect all mounting points for cracks or fatigue, and check the fasteners for proper torque, according to the bolt torque requirements chart on the last page of these instructions.
- The owner must follow the vehicle manufacturer's instructions to prepare the vehicle for towing. Failure to do so may cause severe damage to the vehicle.
- This baseplate is only warranted for the original installation. Installing a used baseplate on another vehicle is not recommended and will void the warranty.



BASEPLATE KIT INSTALLATION INSTRUCTIONS

KIT# 1170-6

02/25/21
KS

ROADMASTER, Inc. 6110 NE 127th Ave. Vancouver, WA 98682 360-896-0407 fax 360-735-9300 www.roadmasterinc.com

This bracket kit is one of our XL series, which is designed to be partly removable (Fig.A). The kit consists of the main receiver brace, two front arm braces, two side braces and a hardware pack. The main receiver brace mounts behind the front bumper fascia under the bumper core and to the frame. The side mounting braces attach to the frame on each side. The front arm braces insert into the receivers on each side. Start by laying the kit out according to the illustration. This will give you a visual idea of how the kit installs and also confirm that all the components are present and accounted for.

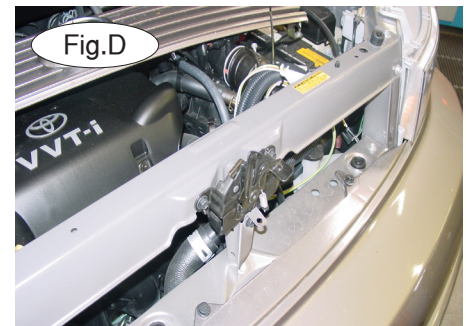
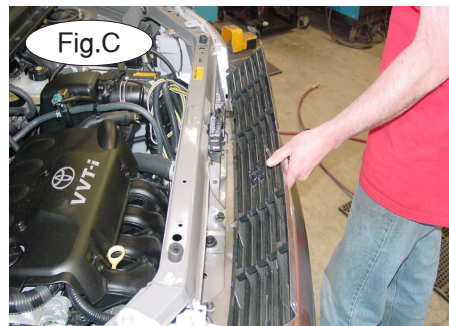
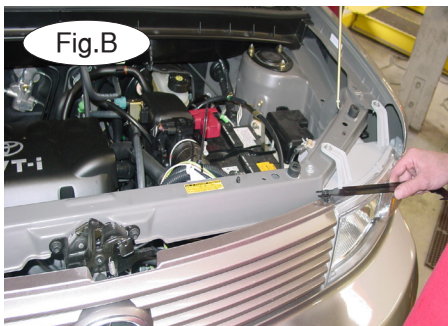

1. **Important:** please use all supplied bolts and parts and read all instructions carefully before beginning this installation. The majority of questions you may have can be answered within the text, and proper installation will ensure safe and secure travel. Now, begin the installation by removing the four plastic fasteners in the top of the front grille then tip forward to remove (Fig.B,C,).

2. Remove three more fasteners (two 10mm head bolts and one plastic) in the top of the bumper fascia (Fig.D).



3. Remove two screws (10mm head) one at each fascia fender junction (Fig.E).

4. Move beneath the vehicle and remove eight screws (10mm head) and one 10mm nut (Fig.F,G). This will release the fascia on the bottom.



BASEPLATE KIT INSTALLATION INSTRUCTIONS

KIT# 1170-6

02/25/21
KS

ROADMASTER, Inc. 6110 NE 127th Ave. Vancouver, WA 98682 360-896-0407 fax 360-735-9300 www.roadmasterinc.com

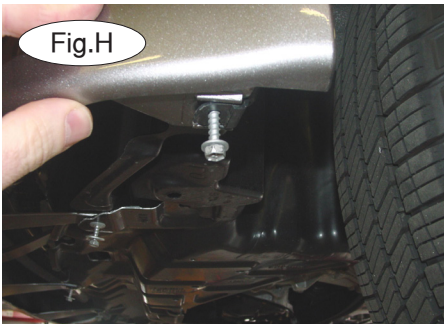

5. Push up on the lower splash panels on each side to release the plastic fasteners (Fig.H), then pull forward and out on each side of the fascia to remove (Fig.I,J) .

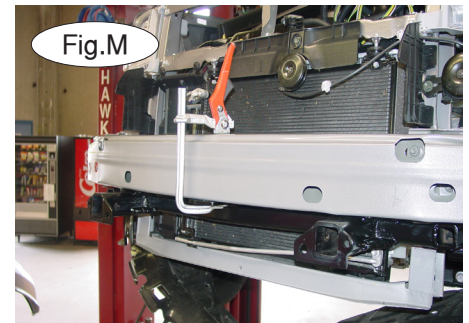
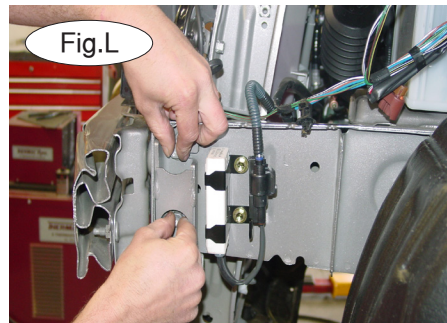
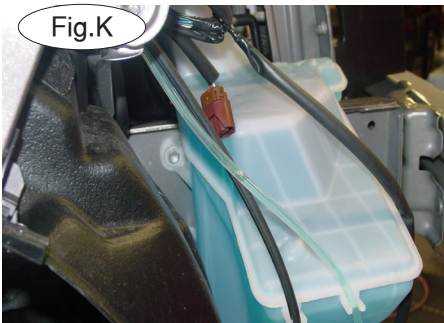

6. Locate the washer reservoir on the passenger side, disconnect and empty or plug then remove (two 10mm head bolts – Fig.K).

7. Remove the side tow hook located on the drivers side (Fig.L). *Note:* retain the hooks and attachment hardware in case the bracket is ever removed.

8. Take the main receiver brace and clamp under the bumper core as shown against the front of the frame on both sides (Fig.M).

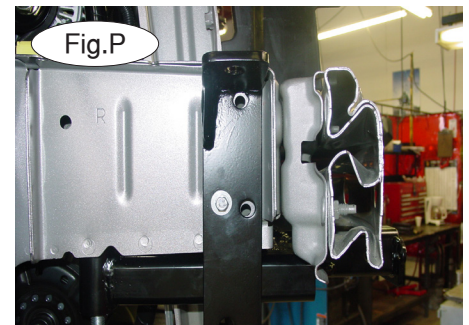
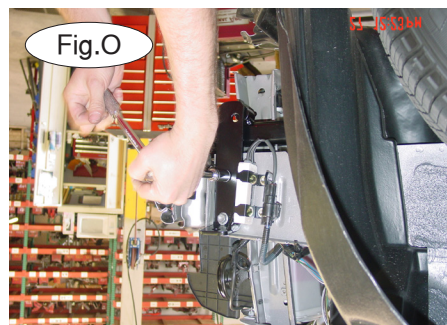
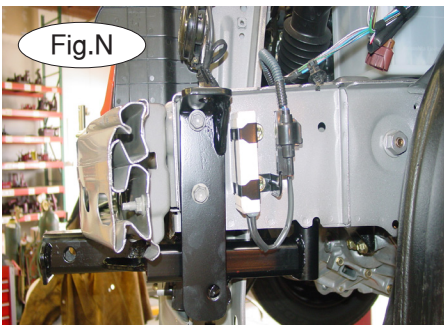

9. Install the drivers side brace on the drivers side with the stock bolts removed in step 7 as shown. Then, bolt through the bottom mounting hole through the main receiver brace with a $\frac{1}{2}$ " x $2\frac{1}{2}$ " bolt, lock washer and nut, align then tighten the bolts (Fig.N,O). *Note:* if the air conditioning line is touching the main receiver brace, bend the air conditioning bracket so they are not touching.

10. Mount the passenger side mounting plate with a washer reservoir bolt removed in step 6, aligning the holes in the mounting plate with smaller existing holes in the frame, tighten to hold in position. Once lined up, use the plate as a drill template and guide to enlarge the holes to $\frac{17}{32}$ " (Fig.P).



BASEPLATE KIT INSTALLATION INSTRUCTIONS

KIT# 1170-6

02/25/21
KS

ROADMASTER, Inc. 6110 NE 127th Ave. Vancouver, WA 98682 360-896-0407 fax 360-735-9300 www.roadmasterinc.com

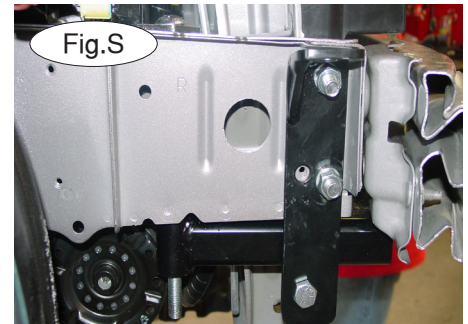
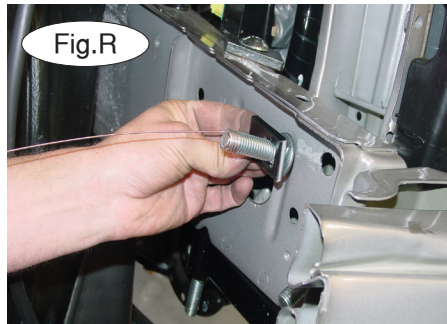

- Using a 1½" hole saw or equivalent, make an access hole in the side of the frame behind the mounting plate (Fig.Q).
- Using the access hole insert or fish wire two ½" x 1½" nut plates into the holes enlarged in step 10 (Fig.R), then bolt through the mounted side plate with 1/2" nuts and lock washers (Fig.S).
- Bolt through the bottom of the side brace with a ½" x 2" bolt, lock washer and nut. Tighten the top and bottom bolts and nuts then remove the reservoir mounting bolt (Fig.S).

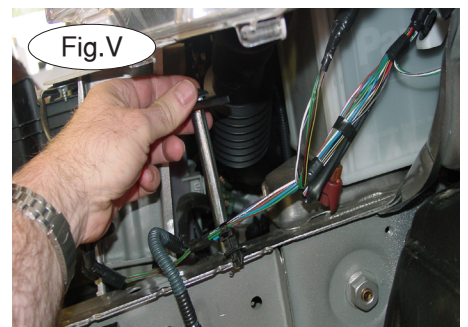
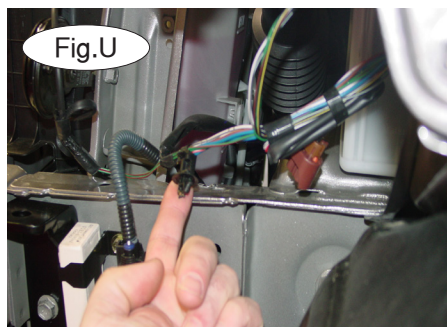
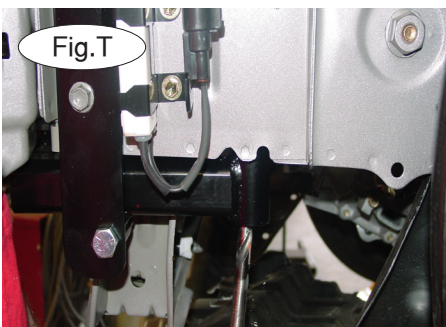

- Using the brace as a drill guide, drill through the top of the frame on each side (Fig.T). On the driver's side, the wiring harness will have to be pulled loose for clearance (Fig.U).
- Install ½" x 9" carriage bolts through the frames and the main receiver brace on each side with 1½" x 2" backing plates on the top of the frames and lock washers and nuts below (Fig.V). Tighten these bolts also.

16. Drill a center mounting hole under the bumper core using the main receiver brace as a drill guide (Fig.W). Only drill through the two lower layers.

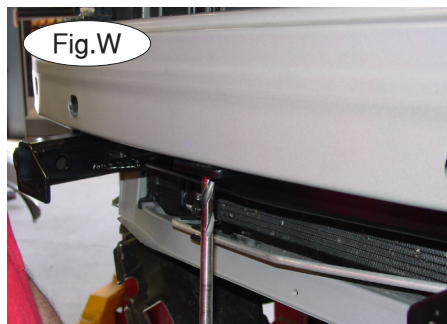

17. Figure X shows the orientation of the ½" x 3" bolt, ½" spacer plate and the 1½" x 3" backing plate. Bolt through the receiver brace, spacer plate, and lower half of the bumper core then finish with a ½" nut and lock washer.



BASEPLATE KIT INSTALLATION INSTRUCTIONS

KIT# 1170-6

02/25/21
KS

ROADMASTER, Inc. 6110 NE 127th Ave. Vancouver, WA 98682 360-896-0407 fax 360-735-9300 www.roadmasterinc.com

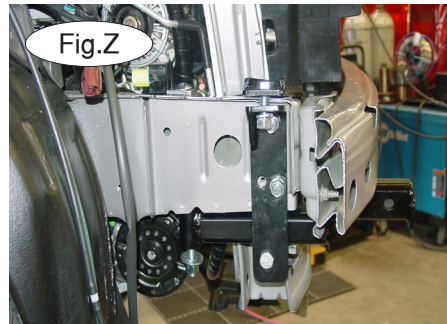
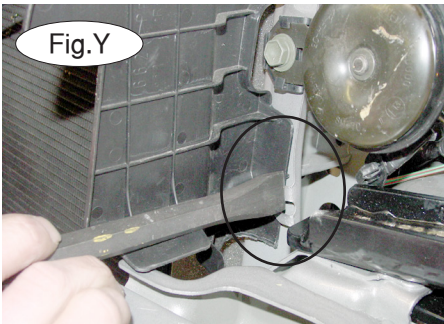

18. Bend the front frame tab over 90 degrees on both sides as shown (Fig.Y). This will provide clearance for the top plates, which will be bolted over the frame on each side.

19. Next bolt through the side plates and top plates with $\frac{1}{2}$ " x $1\frac{1}{2}$ " bolts, lock washers and nuts (Fig.Z).

20. Bolt through the top plate on the inside with $\frac{1}{2}$ " x 8" bolts, lock washers and nuts (Fig.AA).

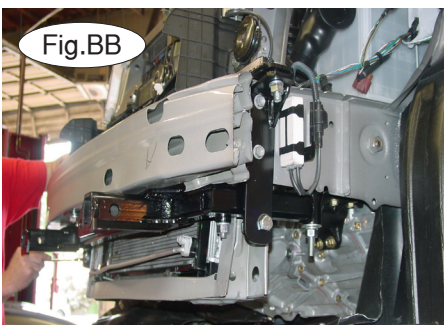

21. Referring to the torque chart at the end of the instructions, tighten the 9" rear bolts first (Fig.BB), then the center bolt and then the remaining side mounting bolts and top mounting bolts (Fig.CC)

22. Refit the washer reservoir reversing step 6, but use the 6mm x 1.0 x 25mm bolt, lock washer, fender washer and $\frac{3}{8}$ " spacer for the bottom mounting bolt (Fig.DD).

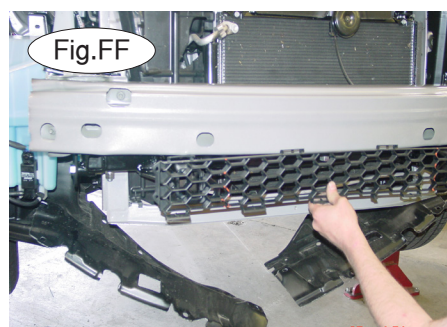

23. Now, remove the lower grille (Fig.EE) from the fascia. Hold the grille in front of the braces and mark the areas that will have to be trimmed (Fig.FF) including the center area (Fig.GG) to clear the braces and the center mounting bolt.



BASEPLATE KIT INSTALLATION INSTRUCTIONS

KIT# 1170-6

02/25/21
KS

ROADMASTER, Inc. 6110 NE 127th Ave. Vancouver, WA 98682 360-896-0407 fax 360-735-9300 www.roadmasterinc.com

24. Reinstall the center grille in the fascia then trial fit the fascia. You will notice interference between the sides of the fascia in the outer grille area and the receiver brace gusseting. Cut a small portion of the fascia to clear on each side (Fig.HH).

25. Reinstall the fascia reversing steps 1 through 5 then reinstall the outer grille sections (Fig.II).

26. Install the front arm braces and secure in place with 5/8" draw pins and 3/16" spring pins.

27. Attach the safety cables to the main receiver brace.



Fig.HH

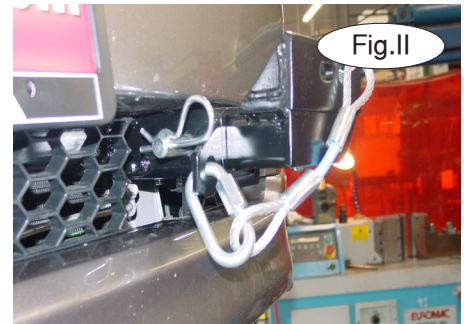

Fig.II

BOLT TORQUE REQUIREMENTS

Note: The torque values represented below are intended as general guidelines. Torque requirements for specific applications may vary. Roadmaster does not warrant this information to be accurate for all applications and disclaims all liability for any claims or damages which may result from its use.

STANDARD BOLTS

Thread Size	Grade	Torque
5/16.....	5.....	13 ft./lb.
3/8.....	5.....	23 ft./lb.
7/16.....	5.....	37 ft./lb.
1/2.....	5.....	56 ft./lb.
5/8.....	5.....	150 ft./lb.

METRIC BOLTS

Thread Size	Grade	Plated / Unplated
8mm-1.0.....	8.8.....	20 ft./lb. 18 ft./lb.
8mm-1.25.....	8.8.....	19 ft./lb. 18 ft./lb.
10mm-1.25.....	8.8.....	38 ft./lb. 36 ft./lb.
10mm-1.5.....	8.8.....	37 ft./lb. 35 ft./lb.

METRIC BOLTS

Thread Size	Grade	Plated / Unplated
12mm-1.25.....	8.8.....	70 ft./lb. 65 ft./lb.
12mm-1.5.....	8.8.....	66 ft./lb. 61 ft./lb.
12mm-1.75.....	8.8.....	65 ft./lb. 60 ft./lb.
14mm-2.0.....	8.8.....	104 ft./lb. 97 ft./lb.

All illustrations and specifications contained herein are based on the latest information available at the time of publication approval. ROADMASTER, INC. reserves the right to make changes at any time without notice in material, specification and models or to discontinue models.