



# BASEPLATE KIT INSTALLATION INSTRUCTIONS

**KIT# 1174-3**

11/19/04  
RV

ROADMASTER, Inc. 6110 NE 127th Ave. Vancouver, WA 98682 360-896-0407 fax 360-735-9300 www.roadmasterinc.com

### Important

*Note: this bracket will not accommodate the Guardian rock shield, some models of the Tow Defender, Stowaway or the StowMaster and StowMaster All Terrain tow bars.*

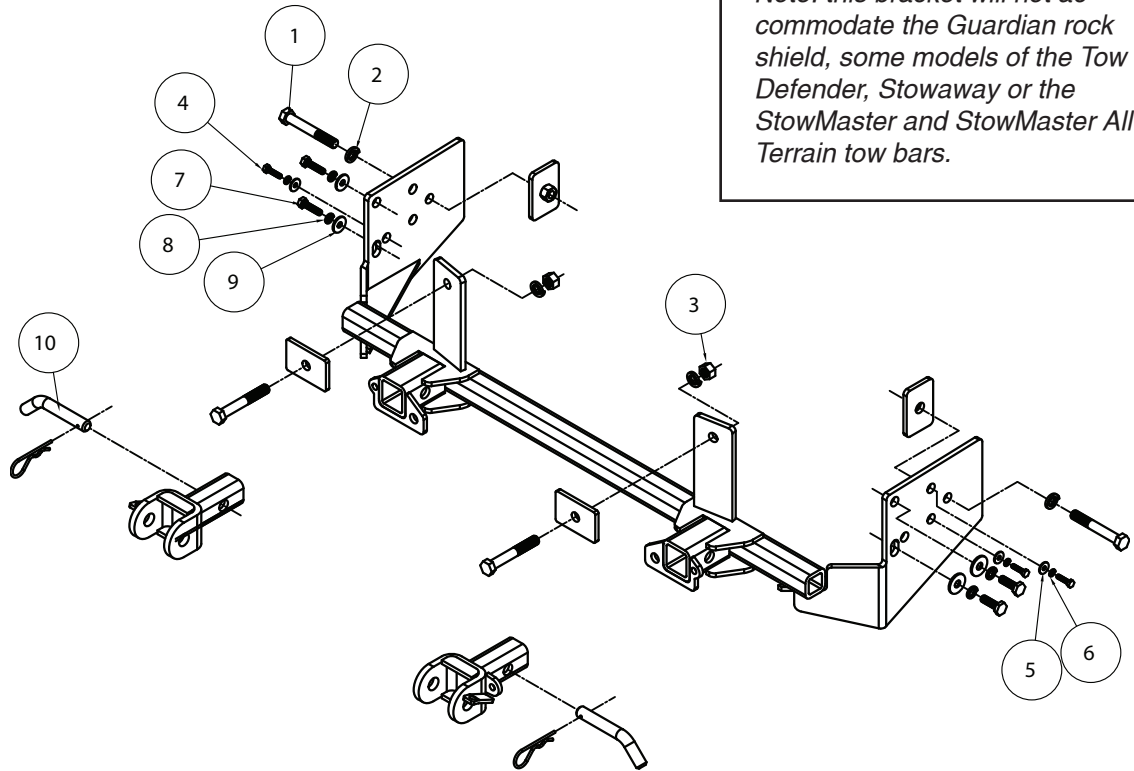

Item	Qty	Length	Width	Name	Material
1.....	4.....	3 1/2".....	1/2".....	BOLT.....	350103-00
2.....	4.....	.....	1/2".....	LOCK WASHER.....	350309-00
3.....	4.....	.....	1/2".....	NUT.....	350258-00
4.....	3.....	6MM.....	25MM.....	6MM x 1.0 x 25MM BOLT.....	355894-00
5.....	3.....	.....	6MM.....	FENDER WASHER.....	355755-00
6.....	3.....	.....	6MM.....	LOCK WASHER.....	355761-00
7.....	2.....	8MM.....	30MM.....	8MM x 1.25 x 30MM.....	356001-00
8.....	2.....	.....	8MM.....	LOCK WASHER.....	355705-00
9.....	2.....	.....	8MM.....	FENDER WASHER.....	355702-00
10.....	2.....	.....	.....	DRAW PIN/SPRING PIN.....	357035-00

ROADMASTER, INC.



# BASEPLATE KIT INSTALLATION INSTRUCTIONS

**KIT# 1174-3**

11/19/04  
RV

ROADMASTER, Inc. 6110 NE 127th Ave. Vancouver, WA 98682 360-896-0407 fax 360-735-9300 www.roadmasterinc.com

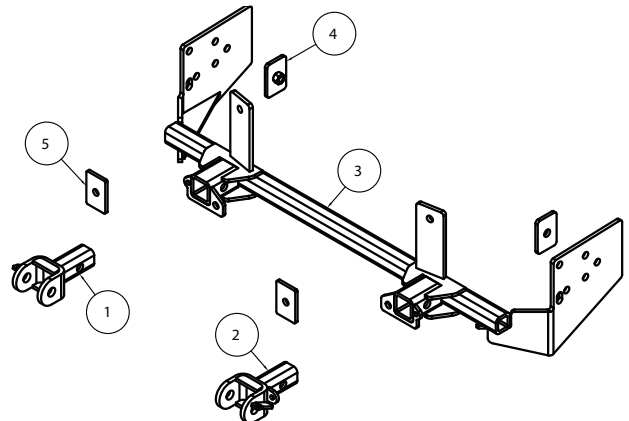

Item	Qty.	Part #	Description
1.....	1 .....	C-001127.....	PASSENGER SIDE ARM BRACE WELDMENT
2.....	1 .....	C-001128.....	DRIVER SIDE ARM BRACE WELDMENT
3.....	1 .....	C-001136.....	RECEIVER BRACE WELDMENT
4.....	2 .....	C-001139.....	1/4" X 3" X 2" THREADED BACKING PLATE
5.....	2 .....	A-000147.....	1/4" X 2" X 3" BACKING PLATE

**IMPORTANT:** All baseplates **must** be assembled with all the bolts left loose for final adjustment and positioning (before tightening) unless otherwise instructed. All bolts **must** be torqued for proper strength. If more than one bolt is used per fastening point, the diagram may only show one. Use flat washers over all slotted holes and lock washers on all fasteners.

## WARNING

Failure to heed these warnings or follow the installation instructions may result in a voided warranty, loss of towed vehicle, personal injury or death.

- Do not weld or modify this baseplate or its components. Welding or modification will void the warranty.
- Do not use this document as a basis to design/fabricate a baseplate, as it may not show all parts or structural components.
- We strongly recommend professional installation.
- If the towed vehicle has been in an accident, it must be properly repaired before attaching the baseplate. Do not install the baseplate if any structural frame damage is found.
- The installer must use all bolts and parts supplied. If running changes were made by the vehicle manufacturer after this kit was designed, some bolts or other fasteners may no longer be the correct size. It is the installer's responsibility to verify this kit is securely fastened to the vehicle.
- Use Loctite® Red on all bolts used to secure this baseplate. Torque all bolts to the specifications found at the end of these instructions. Do not over-torque the bolts or failure may occur.
- The installer must inspect the baseplate to ensure adequate clearance, particularly around hoses, air conditioner lines, radiators, etc. or non-warranty failure may result.
- Roadmaster manufactures many styles of baseplates. If your baseplate has removable arms, they must be removed before driving the vehicle, unless the arms can be pinned or padlocked in place. If not secured, the arms could vibrate out.
- Some motorhome chassis have such a tight turning radius that you can damage your motorhome, towed vehicle, tow bar or baseplate while turning sharply. Before getting on the road, test your turning radius in an empty parking lot. Turning too sharply could

result in non-warranty damage to your towing system, motorhome and/or towed vehicle.

- Do not back up with the towed vehicle attached or non-warranty damage will occur to your towing system or vehicles.
- The safety cables must connect the towing vehicle to the towed vehicle frame to frame, with the cables crossed, with enough slack for sharp turns. See cable instructions for proper routing. Failure to do so will result in non-warranty damage and/or the loss of the towed vehicle.
- This kit is designed for use with ROADMASTER tow bars and ROADMASTER adapters only. Using this kit with other brands, without an approved ROADMASTER adapter, may result in non-warranty damage or injury.
- Receiver extensions and out-of-level towing situations of 3 inches or more. This can cause the system to swing much higher and lower, causing excessive strain on the tow bar, baseplate and frame. That can cause the towing system to fail, causing property damage, personal injury or even death. If you must use a receiver extension or drop hitch to tow, it will reduce your receiver's weight capacity by 1/3 to avoid damaging your system. Never use more than one extension and/or drop hitch, as this will void your warranty.
- Every 3,000 miles, the owner must inspect all mounting points for cracks or fatigue, and check the fasteners for proper torque, according to the bolt torque requirements chart on the last page of these instructions.
- The owner must follow the vehicle manufacturer's instructions to prepare the vehicle for towing. Failure to do so may cause severe damage to the vehicle.
- This baseplate is only warranted for the original installation. Installing a used baseplate on another vehicle is not recommended and will void the warranty.



# BASEPLATE KIT INSTALLATION INSTRUCTIONS

**KIT# 1174-3**

11/19/04  
RV

ROADMASTER, Inc. 6110 NE 127th Ave. Vancouver, WA 98682 360-896-0407 fax 360-735-9300 www.roadmasterinc.com

1. This is one of our MX series brackets, which allows the visible front portion of the brackets to be easily removed from the front of the vehicle (Fig.A and Fig.B). The bracket consists of a main brace, two removable front bracket arms, and a hardware pack.

2. **Important:** please use all supplied bolts and parts and read all instructions carefully before beginning this installation. The majority of questions you may have can be answered within the text, and proper installation will ensure safe and secure travel. Now, begin the installation by removing the plastic fastener at the top of the fascia, near the center (Fig.C).

3. On each side, remove a 10mm bolt at the corner of the fascia and the fender well. (Fig.D).

4. Remove eight 10mm bolts at the bottom of the fascia, along the front edge (Fig.E).

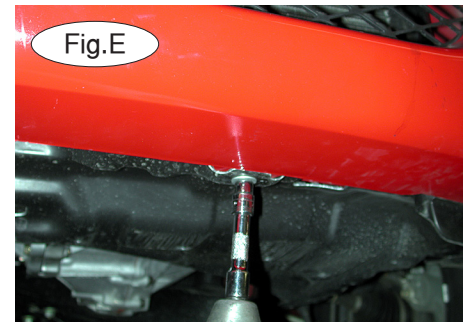
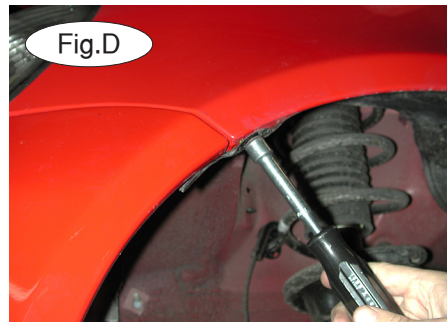
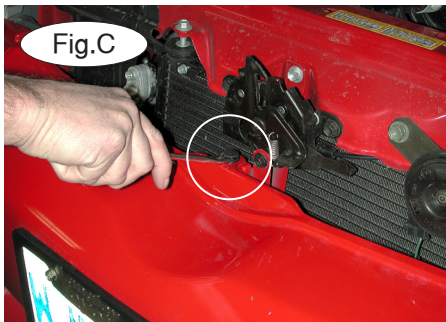

5. Pull down and away on each edge of the fascia to detach it (Fig.F), then unplug the side marker lights (Fig.G) and remove the fascia.

6. Remove two 10mm bolts from the passenger side headlight (Fig.H). Pull forward to detach the headlight, then unplug the three electrical connections (Fig.I) and remove the passenger side headlight.

7. Remove the air deflectors (one on each side) by pulling forward and snapping them out.

(For reassembly, trim them according to the white marker line in Figure J.)

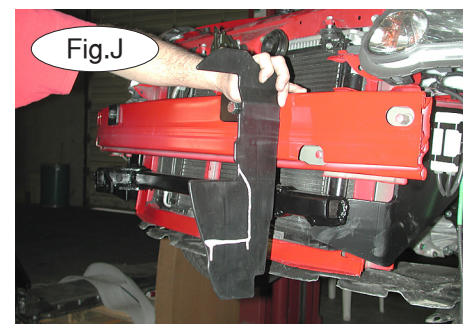



# BASEPLATE KIT INSTALLATION INSTRUCTIONS

**KIT# 1174-3**

11/19/04  
RV

ROADMASTER, Inc. 6110 NE 127th Ave. Vancouver, WA 98682 360-896-0407 fax 360-735-9300 www.roadmasterinc.com

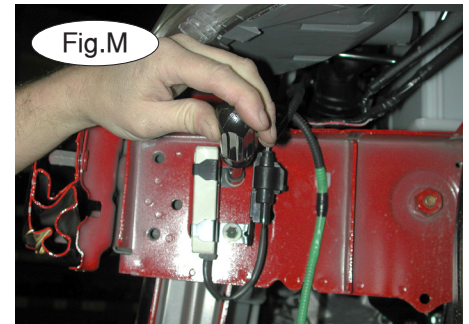
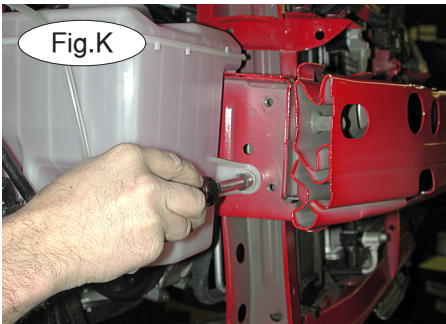

8. Remove the water bottle (on the passenger side) by removing two 10mm head bolts (Fig.K), two electrical connections, and two hoses. *Note:* Before detaching them, mark the plugs and hoses to identify the correct connections, for reassembly (Fig.L).

9. On the driver's side, unbolt the resistor from the frame rail (Fig.M).

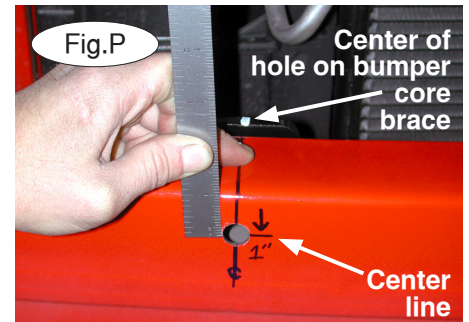
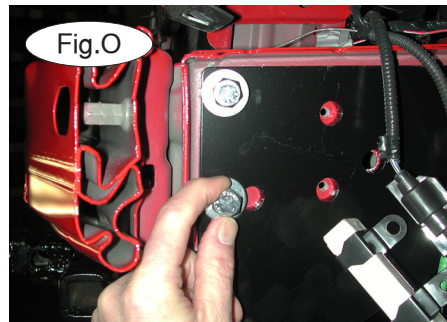
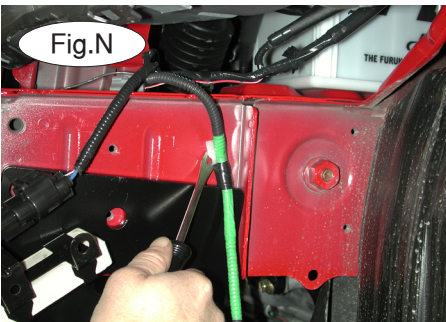

10. Remove the wiring harness retainer on the driver's side (Fig.N).

11. Lift the main bracket brace into position over the frame rails on each side, and bolt onto the existing holes on the outside of the frame rails. Use the two supplied 10mm x 1 1/4" x 30mm bolts, flat washers and lock washers for the driver's side, and the two supplied 8mm x 1 1/4" x 30mm bolts, flat washers and lock washers for the passenger side (Fig.O). Finger-tighten only at this time.

12. Fit one of the removable front bracket arms into the main brace and visually check for level, adjusting the bolts on each side of the main brace if necessary. Once the main brace is level, tighten the two bolts on each side of the main brace to the torque specifications at the bottom of these instructions.

13. Starting from the center of the hole on the top of the bumper core brace, mark a line across the top of the bumper core. Extend the line down one inch from the top of the bumper core (Fig.P) and mark a center line at this point.

14. Drill a 1/2" hole at the center line (Fig.Q), through the bumper core and the hole on the top of the bumper core brace.

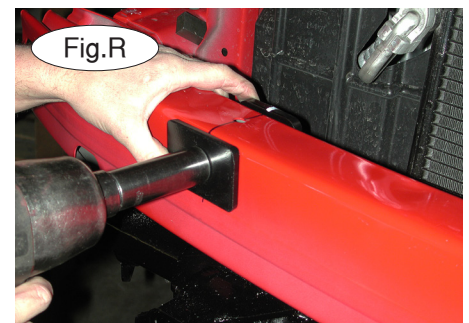
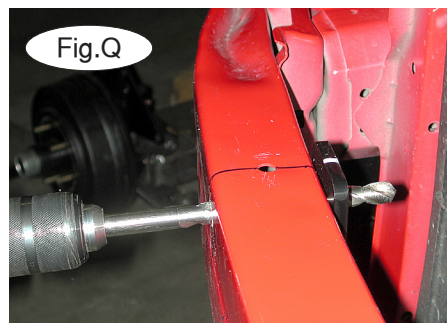

15. Using the supplied 3 1/2" bolt, 1/2" lock washer, 1/2" nuts and the two 1/4" x 2" x 3" backing plates (one on each side), secure the main brace to the bumper core (Fig.R). Torque to the specifications at the bottom of these instructions.



# BASEPLATE KIT INSTALLATION INSTRUCTIONS

**KIT# 1174-3**

11/19/04  
RV

ROADMASTER, Inc. 6110 NE 127th Ave. Vancouver, WA 98682 360-896-0407 fax 360-735-9300 www.roadmasterinc.com

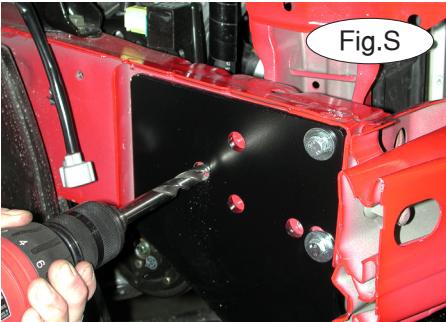

Fig.S

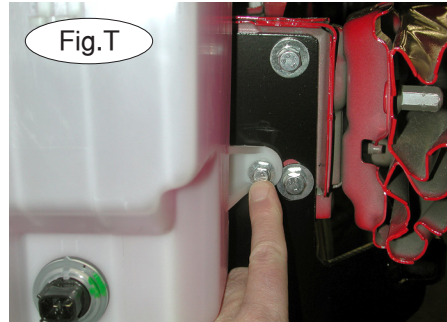

Fig.T

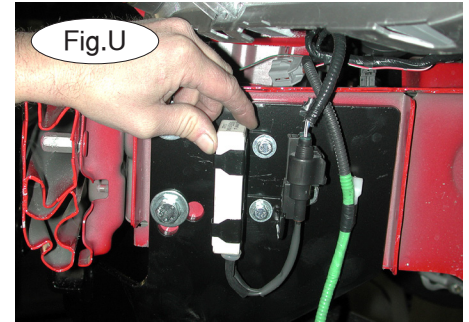

Fig.U

16. Using the rear hole on each side of the main brace as a template, drill through both sides of the frame rail (Fig.S), taking care to avoid the wiring harness and air conditioning lines on the passenger side.

17. Bolt through these holes on each side with the supplied 3½" bolt, and secure the bolts, using the supplied backing plate with welded nut, and a lock washer, to the outside of the frame rail.

18. On the passenger side, reattach the water bottle. Use the supplied 6mm x 1" x 25mm bolt, lock washer and fender washer for the front connection (Fig.T), and a factory bolt for the rear connection.

19. On the driver's side, reattach the resistor (Fig.U), using the supplied 6mm x 1" x 25mm bolts, lock washers and fender washers.

20. Reinstall the fascia by reversing steps 2 through 5. *Note:* Trim the grill, using the white marker line in Fig.V as a reference, or discard the grille.



Fig.V



Fig.W

21. Fit the front bracket arms into the front receiver braces (Fig.W), and secure them in place with the supplied 5/8" draw pins and spring pins.

22. Install the tow bar to the mounting bracket according to the manufacturer's instructions. Attach the safety cables to the main receiver brace.

## BOLT TORQUE REQUIREMENTS

Note: The torque values represented below are intended as general guidelines. Torque requirements for specific applications may vary. Roadmaster does not warrant this information to be accurate for all applications and disclaims all liability for any claims or damages which may result from its use.

### STANDARD BOLTS

Thread Size	Grade	Torque
5/16.....	5.....	13 ft./lb.
3/8.....	5.....	23 ft./lb.
7/16.....	5.....	37 ft./lb.
1/2.....	5.....	56 ft./lb.
5/8.....	5.....	150 ft./lb.

### METRIC BOLTS

Thread Size	Grade	Plated / Unplated
8mm-1.0.....	8.8.....	20 ft./lb. 18 ft./lb.
8mm-1.25.....	8.8.....	19 ft./lb. 18 ft./lb.
10mm-1.25.....	8.8.....	38 ft./lb. 36 ft./lb.
10mm-1.5.....	8.8.....	37 ft./lb. 35 ft./lb.

### METRIC BOLTS

Thread Size	Grade	Plated / Unplated
12mm-1.25.....	8.8.....	70 ft./lb. 65 ft./lb.
12mm-1.5.....	8.8.....	66 ft./lb. 61 ft./lb.
12mm-1.75.....	8.8.....	65 ft./lb. 60 ft./lb.
14mm-2.0.....	8.8.....	104 ft./lb. 97 ft./lb.

All illustrations and specifications contained herein are based on the latest information available at the time of publication approval. ROADMASTER, INC. reserves the right to make changes at any time without notice in material, specification and models or to discontinue models.