



BASEPLATE KIT INSTALLATION INSTRUCTIONS

KIT# 1175-3

06/09/16
KS

ROADMASTER, Inc. 6110 NE 127th Ave. Vancouver, WA 98682 360-896-0407 fax 360-735-9300 www.roadmasterinc.com

Important

Note: this bracket will not accommodate the Guardian rock shield, some models of the Tow Defender, Stowaway or the StowMaster and StowMaster All Terrain tow bars.

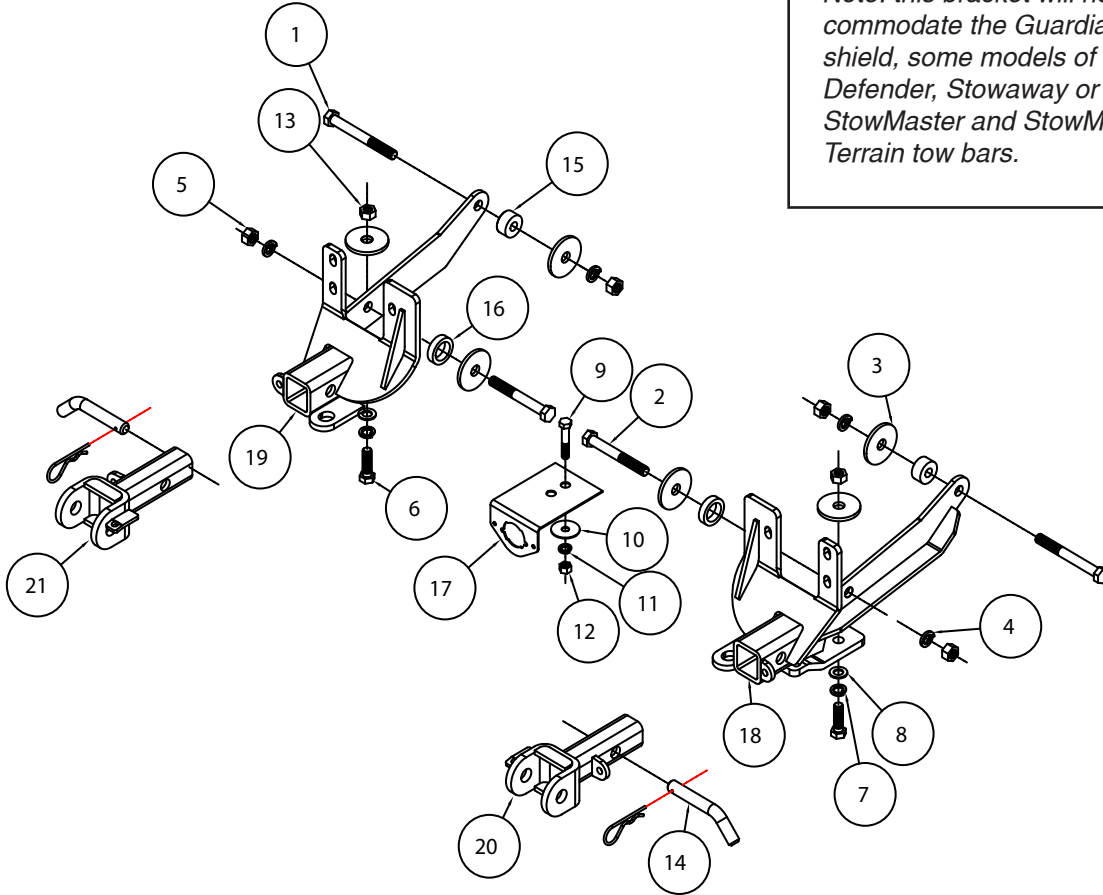

ITEM	QTY	NAME	MATERIAL
1.....2.....	2.....	1/2" x 4 1/2" BOLT.....	350106-00
2.....2.....	2.....	1/2" x 4" BOLT.....	350105-00
3.....6.....	6.....	1/2" PLATE WASHER.....	350354-00
4.....4.....	4.....	1/2" LOCK WASHER.....	350309-00
5.....4.....	4.....	1/2" HEX NUT.....	350258-00
6.....2.....	2.....	12mm x 1.25 x 40mm BOLT.....	357003-00
7.....2.....	2.....	12mm LOCK WASHER.....	355725-00
8.....2.....	2.....	12mm FLAT WASHER.....	355720-00
9.....1.....	1.....	3/8" x 2" BOLT.....	350059-00
10.....1.....	1.....	3/8" FENDER WASHER.....	350305-10
11.....1.....	1.....	3/8" LOCK WASHER.....	350305-00
12.....1.....	1.....	3/8" HEX NUT.....	350254-00
13.....2.....	2.....	12mm HEX NUT.....	356240-00
14.....2.....	2.....	5/8" DRAW PIN W/ CLIP.....	357035-00
15.....2.....	2.....	1 1/4" O.D. x 0.375 x 5/8" PIPE SPACER.....	A-000908
16.....2.....	2.....	1 1/2" O.D. x 0.219 x 3/8" PIPE SPACER.....	A-001826
17.....1.....	1.....	WIRE PLUG CONNECTOR PLATE.....	B-000777
18.....1.....	1.....	DRIVER SIDE RECEIVER.....	C-001140
19.....1.....	1.....	PASSENGER SIDE RECEIVER.....	C-001141
20.....1.....	1.....	DRIVER SIDE ARM.....	C-000985
21.....1.....	1.....	PASSENGER SIDE ARM.....	C-000986



BASEPLATE KIT INSTALLATION INSTRUCTIONS

KIT# 1175-3

06/09/16
KS

ROADMASTER, Inc. 6110 NE 127th Ave. Vancouver, WA 98682 360-896-0407 fax 360-735-9300 www.roadmasterinc.com

This is one of our MX series brackets, which allows the visible front portion of the brackets to be easily removed from the front of the vehicle (Fig.A and Fig.B). The bracket kit consists of two main receiver braces and a hardware pack.

Before starting the installation, lay out the kit components in order, as they will be used. This will give you a visual idea of how the components work, and will also confirm that everything is present and accounted for.



IMPORTANT: All baseplates **must** be assembled with all the bolts left loose for final adjustment and positioning (before tightening) unless otherwise instructed. All bolts **must** be torqued for proper strength. If more than one bolt is used per fastening point, the diagram may only show one. Use flat washers over all slotted holes and lock washers on all fasteners.

WARNING

Failure to heed these warnings or follow the installation instructions may result in a voided warranty, loss of towed vehicle, personal injury or death.

- Do not weld or modify this baseplate or its components. Welding or modification will void the warranty.
- Do not use this document as a basis to design/fabricate a baseplate, as it may not show all parts or structural components.
- We strongly recommend professional installation.
- If the towed vehicle has been in an accident, it must be properly repaired before attaching the baseplate. Do not install the baseplate if any structural frame damage is found.
- The installer must use all bolts and parts supplied. If running changes were made by the vehicle manufacturer after this kit was designed, some bolts or other fasteners may no longer be the correct size. It is the installer's responsibility to verify this kit is securely fastened to the vehicle.
- Use Loctite® Red on all bolts used to secure this baseplate. Torque all bolts to the specifications found at the end of these instructions. Do not over-torque the bolts or failure may occur.
- The installer must inspect the baseplate to ensure adequate clearance, particularly around hoses, air conditioner lines, radiators, etc. or non-warranty failure may result.
- Roadmaster manufactures many styles of baseplates. If your baseplate has removable arms, they must be removed before driving the vehicle, unless the arms can be pinned or padlocked in place. If not secured, the arms could vibrate out.
- Some motorhome chassis have such a tight turning radius that you can damage your motorhome, towed vehicle, tow bar or baseplate while turning sharply. Before getting on the road, test your turning radius in an empty parking lot. Turning too sharply could result in non-warranty damage to your towing system, motorhome and/or towed vehicle.
- Do not back up with the towed vehicle attached or non-warranty damage will occur to your towing system or vehicles.
- The safety cables must connect the towing vehicle to the towed vehicle frame to frame, with the cables crossed, with enough slack for sharp turns. See cable instructions for proper routing. Failure to do so will result in non-warranty damage and/or the loss of the towed vehicle.
- This kit is designed for use with ROADMASTER tow bars and ROADMASTER adapters only. Using this kit with other brands, without an approved ROADMASTER adapter, may result in non-warranty damage or injury.
- Receiver extensions and out-of-level towing situations of 3 inches or more. This can cause the system to swing much higher and lower, causing excessive strain on the tow bar, baseplate and frame. That can cause the towing system to fail, causing property damage, personal injury or even death. If you must use a receiver extension or drop hitch to tow, it will reduce your receiver's weight capacity by 1/3 to avoid damaging your system. Never use more than one extension and/or drop hitch, as this will void your warranty.
- Every 3,000 miles, the owner must inspect all mounting points for cracks or fatigue, and check the fasteners for proper torque, according to the bolt torque requirements chart on the last page of these instructions.
- The owner must follow the vehicle manufacturer's instructions to prepare the vehicle for towing. Failure to do so may cause severe damage to the vehicle.
- This baseplate is only warranted for the original installation. Installing a used baseplate on another vehicle is not recommended and will void the warranty.



BASEPLATE KIT INSTALLATION INSTRUCTIONS

KIT# 1175-3

06/09/16
KS

ROADMASTER, Inc. 6110 NE 127th Ave. Vancouver, WA 98682 360-896-0407 fax 360-735-9300 www.roadmasterinc.com

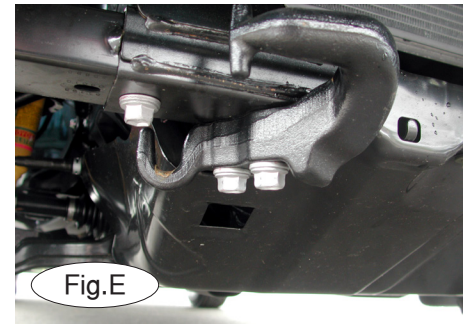
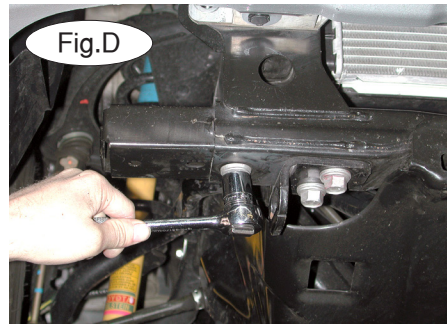
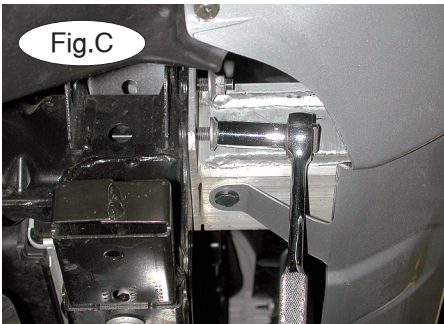

1. **Important:** please use all supplied bolts and parts and read all instructions carefully before beginning this installation. The majority of questions you may have can be answered within the text, and proper installation will ensure safe and secure travel. Now, begin the installation by removing, on each side, three 14mm head nuts on the bumper support – two on the outside, and one on the inside (Fig.C).

2. Next, on each side, remove the 17mm head bolt holding the frame cap (Fig.D). Then, remove the frame caps.

Note: the frame caps are only on 4-wheel drive and Prerunner models. The standard two-wheel drive models do not have a frame cap, and a hole must be drilled in the frame to mount the bracket. See the note in step 6 below.

3. If the vehicle is equipped with a larger tow hook (Fig.E), remove the tow hook.

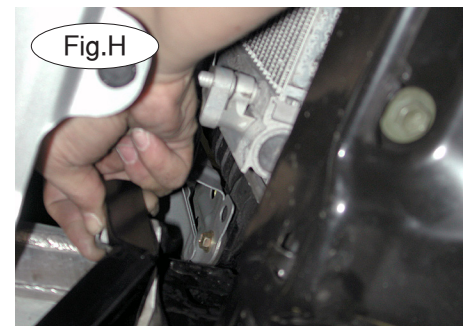
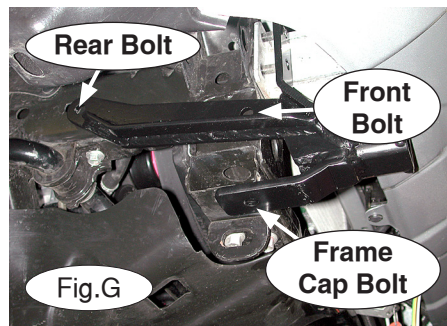

4. Position the driver's side and the passenger side main receiver braces – First, slide each brace over the bumper support (Fig.F). Then, slide the brace back over the bumper support studs. Figure G shows a brace in position to be bolted, as well as the location of the three bolts which will hold it in place.

5. Replace the three 14mm (head) nuts, on each side of the bumper support, which you removed in step 1 (Fig.H). *Note:* use thread lock on the factory bolts prior to reinstalling the nuts.



BASEPLATE KIT INSTALLATION INSTRUCTIONS

KIT# 1175-3

06/09/16
KS

ROADMASTER, Inc. 6110 NE 127th Ave. Vancouver, WA 98682 360-896-0407 fax 360-735-9300 www.roadmasterinc.com

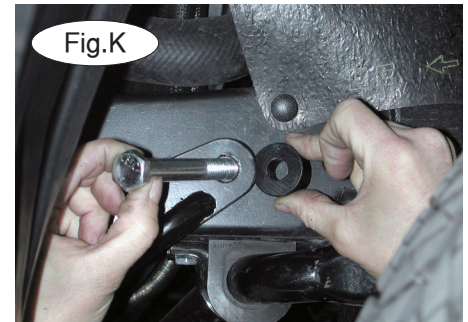
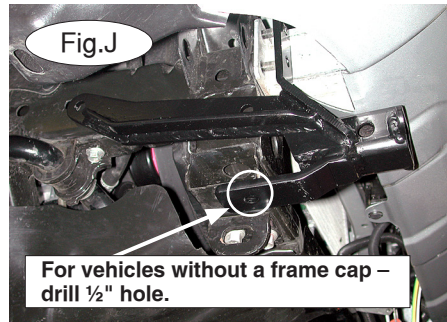
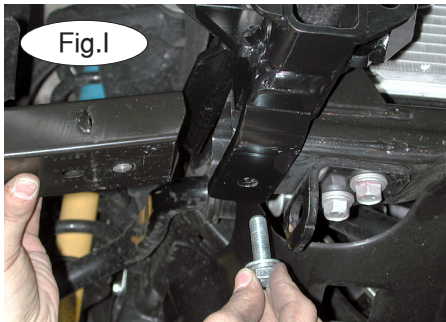

6. Replace the frame caps you removed in step 2, and bolt through the lower part of each main brace with a 12mm x 1.25" x 40mm bolt, flat washer and lock washer (Fig.I).

Note: standard two-wheel drive models do not have a frame cap, and a hole must be drilled in the frame rail to mount each main receiver bracket. Figure J shows where the hole is to be drilled on each frame rail.

Once the main brace is positioned over the frame rail, use the hole in the main receiver brace as a template, and drill a 1/2" hole through the bottom of the frame rail. Bolt through with a 12mm x 1.25 x 4mm bolt and flat washer from the bottom. On the inside of the frame rail, put a 1/2" plate washer over the bolt, and finish with a 12mm lock washer and nut. Repeat for the other side.

7. Next, bolt the rear of the main braces to the frame. On the outside of the frame, insert one of the 4 1/2" bolts through the existing hole in the frame, with a 1 1/4" x 5/8" pipe spacer between the brace and the frame (Fig.K). Figure L shows the bolt in place, with the pipe spacer between the brace and the frame. Repeat for the other side. *Note:* due to manufacturing variances, the rear holes may need to be enlarged if existing or drilled if non-existent.

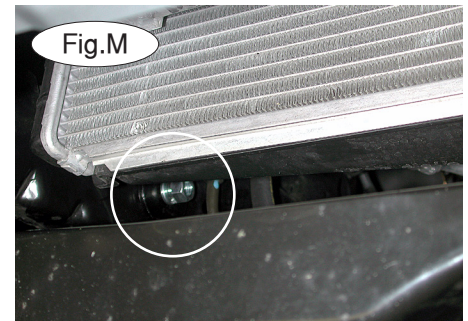
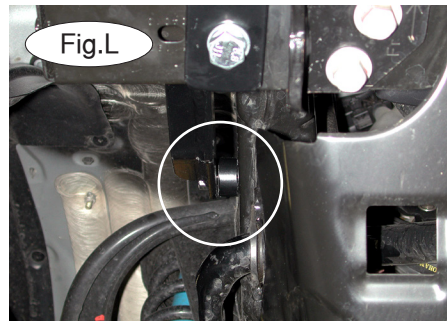

8. Next, from the inside of the frame, thread a 1/2" plate washer, 1/2" lock washer and 1/2" nut onto each rear bolt to secure them in place (Fig.M).

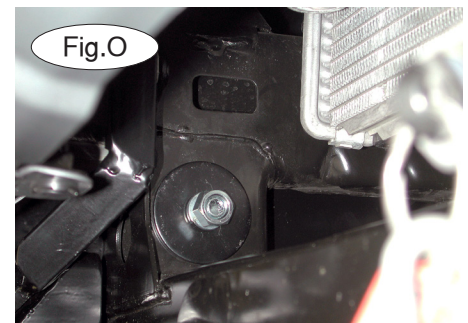
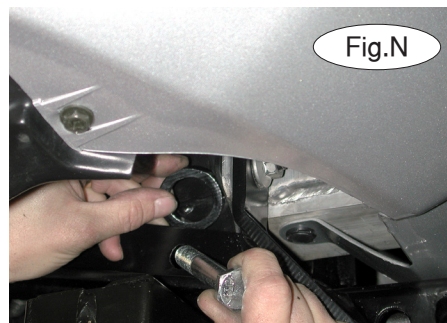

9. To mount the front bolts, insert a 1 1/2" x 3/8" pipe spacer between the frame and the brace. From the outside of the frame, bolt through the existing hole with a 1/2" x 4" bolt (Fig.M). From the inside of the frame, thread a 1/2" plate washer, lock washer and nut onto the bolt to secure it (Fig.O). Repeat for the other side.



BASEPLATE KIT INSTALLATION INSTRUCTIONS

KIT# 1175-3

06/09/16
KS

ROADMASTER, Inc. 6110 NE 127th Ave. Vancouver, WA 98682 360-896-0407 fax 360-735-9300 www.roadmasterinc.com

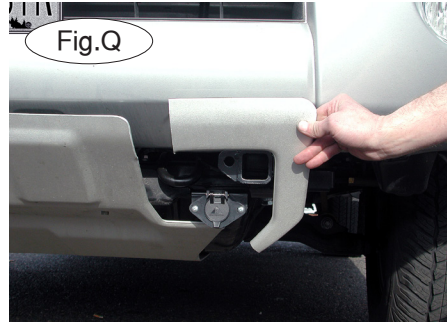
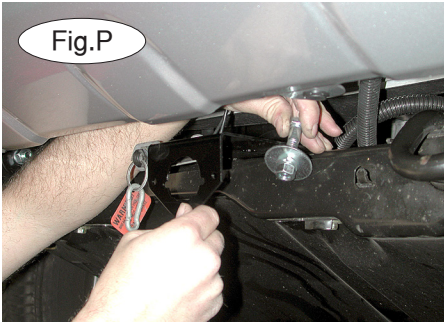

10. Bolt the supplied light plug bracket to the frame cross member, using one of the pre-existing holes. Use a 1-3/8" x 2" bolt, fender washer, lock washer and nut (Fig.P).
11. Tighten all bolts to the torque specifications at the bottom of these instructions.
12. If the vehicle is equipped with a rock guard, it must be removed and trimmed on each side to accommodate the mounting bracket and receiver braces. Figure Q shows the approximate amount to trim on each side; Figure R shows the trimmed rock guard and bracket.
13. Fit the front bracket arms into the receiver braces, and secure them in place with the supplied 5/8" draw pins and spring clips (Fig.S).
14. Install the tow bar to the mounting bracket according to the manufacturer's instructions. Connect the safety cables to the safety cable tabs illustrated on the first page of these instructions.

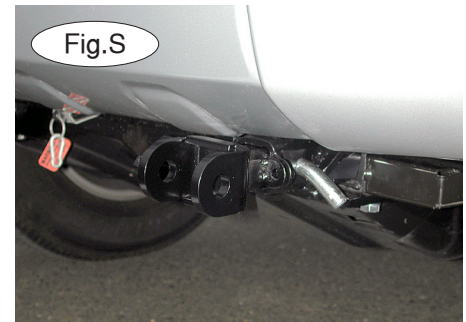

BOLT TORQUE REQUIREMENTS

Note: The torque values represented below are intended as general guidelines. Torque requirements for specific applications may vary. Roadmaster does not warrant this information to be accurate for all applications and disclaims all liability for any claims or damages which may result from its use.

STANDARD BOLTS

Thread Size	Grade	Torque
5/16	5	13 ft./lb.
3/8	5	23 ft./lb.
7/16	5	37 ft./lb.
1/2	5	56 ft./lb.
5/8	5	150 ft./lb.

METRIC BOLTS

Thread Size	Grade	Plated / Unplated
8mm-1.0	8.8	20 ft./lb. 18 ft./lb.
8mm-1.25	8.8	19 ft./lb. 18 ft./lb.
10mm-1.25	8.8	38 ft./lb. 36 ft./lb.
10mm-1.5	8.8	37 ft./lb. 35 ft./lb.

METRIC BOLTS

Thread Size	Grade	Plated / Unplated
12mm-1.25	8.8	70 ft./lb. 65 ft./lb.
12mm-1.5	8.8	66 ft./lb. 61 ft./lb.
12mm-1.75	8.8	65 ft./lb. 60 ft./lb.
14mm-2.0	8.8	104 ft./lb. 97 ft./lb.

All illustrations and specifications contained herein are based on the latest information available at the time of publication approval. ROADMASTER, INC. reserves the right to make changes at any time without notice in material, specification and models or to discontinue models.