



BASEPLATE KIT INSTALLATION INSTRUCTIONS

KIT# 1176-1

04/04/05
RV

ROADMASTER, Inc. 6110 NE 127th Ave. Vancouver, WA 98682 1-800-669-9690 fax 360-735-9300 www.roadmasterinc.com

ROADMASTER, INC.

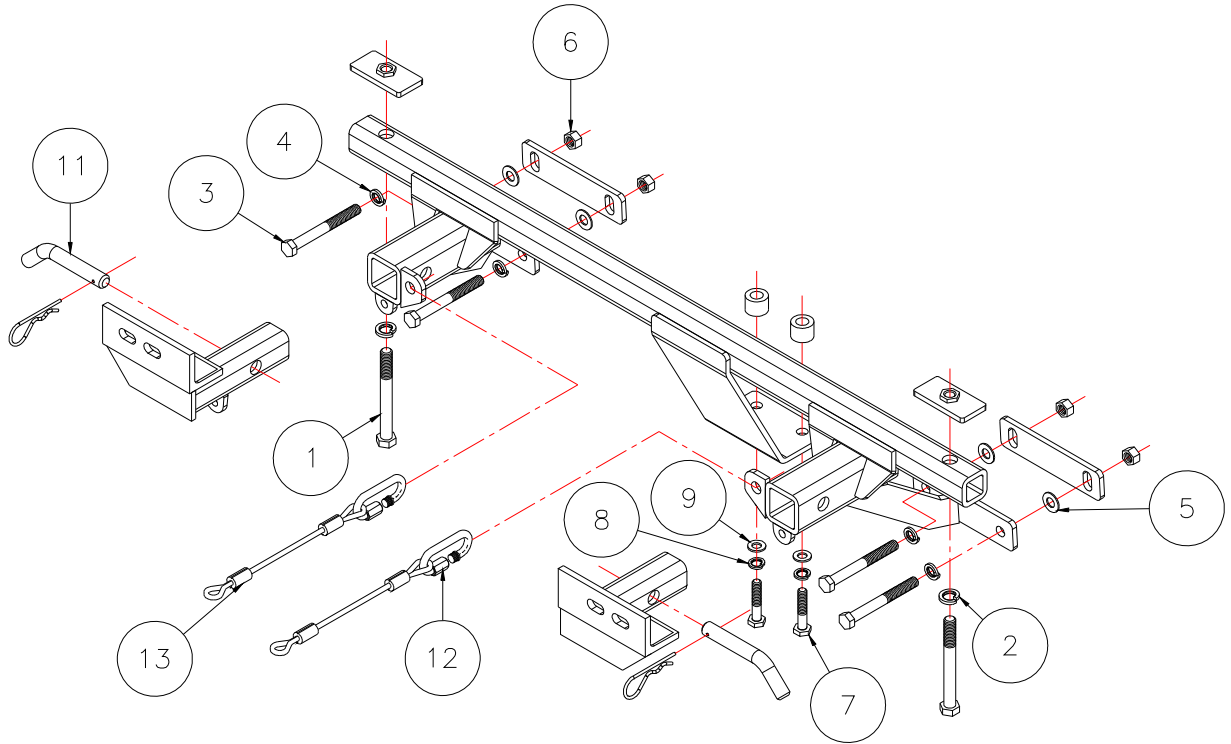

Item	Qty	Length	Width	Description	Part #
1	2	4 1/2"	1/2"	1/2" x 4 1/2" BOLT	350106-00
2	2		1/2"	LOCK WASHER	350309-00
3	4	4"	7/16"	7/16" x 4" BOLT	350084-00
4	4		7/16"	LOCK WASHER	350307-00
5	4		7/16"	FLAT WASHER	350345-00
6	4		7/16"	NUT	350256-00
7	2	50mm	10mm	M10 x 1.25 x 50 BOLT	356205-00
8	2		10mm	LOCK WASHER	355715-00
9	2		10mm	FLAT WASHER	355710-00
10	2			FLAT WASHER	355710-00
11	2		5/8"	DRAW PINS, SPRING PINS	357035-00
12	2			CABLE CONNECTOR	200008-00
13	2	8"		SAFETY CABLE	500646-08



BASEPLATE KIT INSTALLATION INSTRUCTIONS

KIT# 1176-1

04/04/05
RV

ROADMASTER, Inc. 6110 NE 127th Ave. Vancouver, WA 98682 1-800-669-9690 fax 360-735-9300 www.roadmasterinc.com

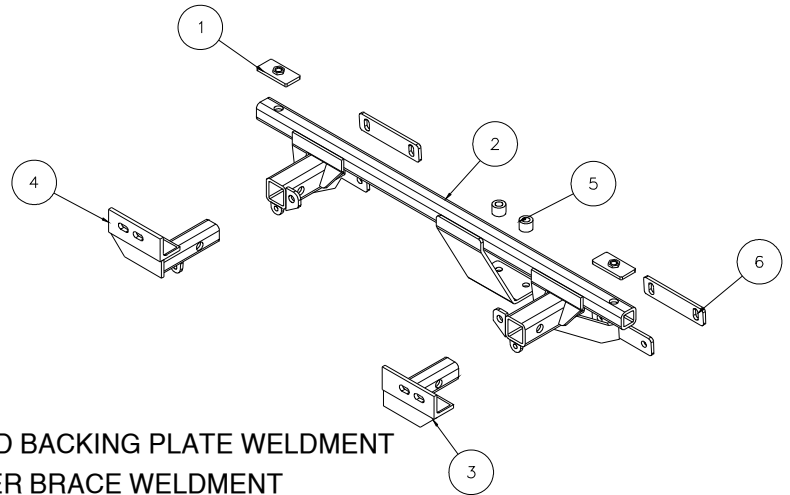

Item	Qty.	Part #	Description
1	2	C-001170	1/2" THREADED BACKING PLATE WELDMENT
2	1	C-001223	MAIN RECEIVER BRACE WELDMENT
3	1	C-001224	DRIVER SIDE ARM BRACE WELDMENT
4	1	C-001225	PASSENGER SIDE ARM BRACE WELDMENT
5	2	A-000558	1" O.D. x 3/4" x .219 WALL ROUND TUBE

IMPORTANT: All baseplates **must** be assembled with all the bolts left loose for final adjustment and positioning (before tightening) unless otherwise instructed. All bolts **must** be torqued for proper strength. If more than one bolt is used per fastening point, the diagram may only show one. Use flat washers over all slotted holes and lock washers on all fasteners.

WARNING

Failure to heed these warnings or follow the installation instructions may result in a voided warranty, loss of towed vehicle, personal injury or death.

- Do not weld or modify this baseplate or its components. Welding or modification will void the warranty.
- Do not use this document as a basis to design/fabricate a baseplate, as it may not show all parts or structural components.
- We strongly recommend professional installation.
- If the towed vehicle has been in an accident, it must be properly repaired before attaching the baseplate. Do not install the baseplate if any structural frame damage is found.
- The installer must use all bolts and parts supplied. If running changes were made by the vehicle manufacturer after this kit was designed, some bolts or other fasteners may no longer be the correct size. It is the installer's responsibility to verify this kit is securely fastened to the vehicle.
- Use Loctite® Red on all bolts used to secure this baseplate. Torque all bolts to the specifications found at the end of these instructions. Do not over-torque the bolts or failure may occur.
- The installer must inspect the baseplate to ensure adequate clearance, particularly around hoses, air conditioner lines, radiators, etc. or non-warranty failure may result.
- Roadmaster manufactures many styles of baseplates. If your baseplate has removable arms, they must be removed before driving the vehicle, unless the arms can be pinned or padlocked in place. If not secured, the arms could vibrate out.
- Some motorhome chassis have such a tight turning radius that you can damage your motorhome, towed vehicle, tow bar or baseplate while turning sharply. Before getting on the road, test your turning radius in an empty parking lot. Turning too sharply could

result in non-warranty damage to your towing system, motorhome and/or towed vehicle.

- Do not back up with the towed vehicle attached or non-warranty damage will occur to your towing system or vehicles.
- The safety cables must connect the towing vehicle to the towed vehicle frame to frame, with the cables crossed, with enough slack for sharp turns. See cable instructions for proper routing. Failure to do so will result in non-warranty damage and/or the loss of the towed vehicle.
- This kit is designed for use with ROADMASTER tow bars and ROADMASTER adapters only. Using this kit with other brands, without an approved ROADMASTER adapter, may result in non-warranty damage or injury.
- Receiver extensions and out-of-level towing situations of 3 inches or more. This can cause the system to swing much higher and lower, causing excessive strain on the tow bar, baseplate and frame. That can cause the towing system to fail, causing property damage, personal injury or even death. If you must use a receiver extension or drop hitch to tow, it will reduce your receiver's weight capacity by 1/3 to avoid damaging your system. Never use more than one extension and/or drop hitch, as this will void your warranty.
- Every 3,000 miles, the owner must inspect all mounting points for cracks or fatigue, and check the fasteners for proper torque, according to the bolt torque requirements chart on the last page of these instructions.
- The owner must follow the vehicle manufacturer's instructions to prepare the vehicle for towing. Failure to do so may cause severe damage to the vehicle.
- This baseplate is only warranted for the original installation. Installing a used baseplate on another vehicle is not recommended and will void the warranty.



BASEPLATE KIT INSTALLATION INSTRUCTIONS

KIT# 1176-1

04/04/05
RV

ROADMASTER, Inc. 6110 NE 127th Ave. Vancouver, WA 98682 1-800-669-9690 fax 360-735-9300 www.roadmasterinc.com

This is one of our XL series brackets, which allows the visible front portion of the brackets to be easily removed from the front of the vehicle (Fig.A and Fig.B). The bracket consists of a main receiver brace, two removable front braces and a hardware pack.

The main receiver brace mounts to the motor support, the core support and the bumper core. The removable front braces install in the main receiver brace.

1. **Important: please use all supplied bolts and parts and read all instructions carefully before beginning this installation. The majority of questions you may have can be answered within the text, and proper installation will ensure safe and secure travel.** Now, begin the installation by removing five fasteners (two with rubber tops) across the top of the fascia (Fig.C). The fasteners hold the top of the fascia to the core support.

2. Next, remove five 10mm (head) screws across the bottom front of the fascia (Fig.D). The screws hold the splash shield to the fascia.

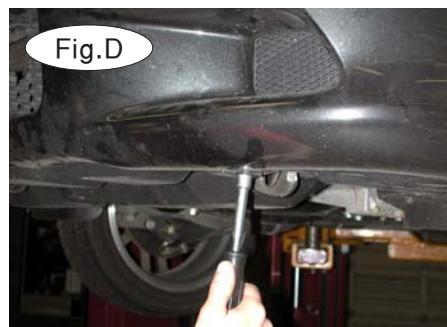
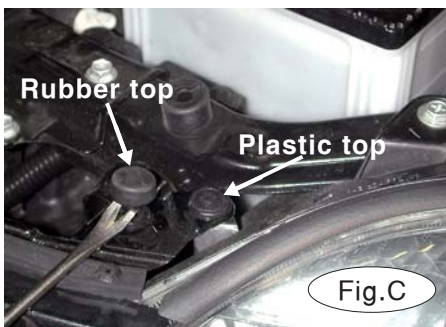

3. Remove one 10mm (head) screw, holding the fender liner to the fascia, from the edge of each wheel well (Fig.E).



4. Next, remove four 10mm (head) screws and seven plastic fasteners holding the left and right splash shields to the subframe (Fig.F). Then, remove both splash shields (Fig.G).

5. On each side, pull back the fender liner and remove one 10mm (head) screw, holding the corner of the fascia to the fender (Fig.H).



BASEPLATE KIT INSTALLATION INSTRUCTIONS

KIT# 1176-1

04/04/05
RV

ROADMASTER, Inc. 6110 NE 127th Ave. Vancouver, WA 98682 1-800-669-9690 fax 360-735-9300 www.roadmasterinc.com

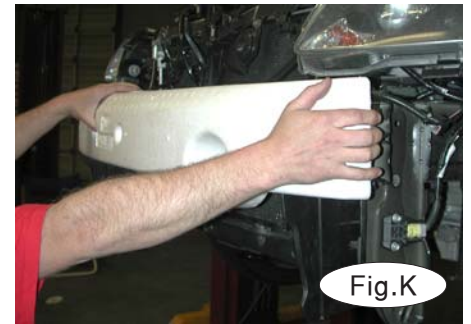

6. Disconnect the fog lights, if the vehicle is so equipped. Then, pull out and forward at each corner of the fascia to release it from the lock strip (Fig.I). Pull forward from the center (Fig.J) and remove the fascia.

7. Remove the shock absorption pad (Fig.K).

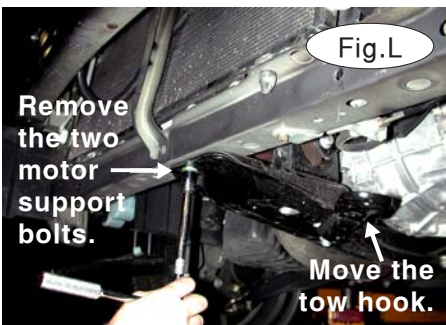

8. The front of the tow hook is close to the center attachment for the main brace, and you may wish to move the tow hook out of the way before attaching the main brace. If so, loosen the rear bolt on the tow hook, remove the front bolt, and swing the tow hook to one side (Fig.L).

9. Next, remove the two 14mm (head) motor support bolts (Fig.L).

10. Lift the main receiver brace into position, with the two 3/4" x .219 wall x 1" pipe spacers over the pre-drilled holes in the center of the main brace (Fig.M). Align the center of the brace, and the pipe spacers, over the holes for the motor support bolts you removed in the previous step.

11. Attach the center of the brace to the motor support with the two supplied 10mm x 1.25 x 50mm bolts, flat washers and lock washers (Fig.N). Tighten the bolts just enough to hold them in place.

12. Before attaching the main receiver brace to the bumper core, check to make sure the brace is parallel to the front of the car – both ends of the brace should be approximately flush with the face of the bumper core (Fig.O).

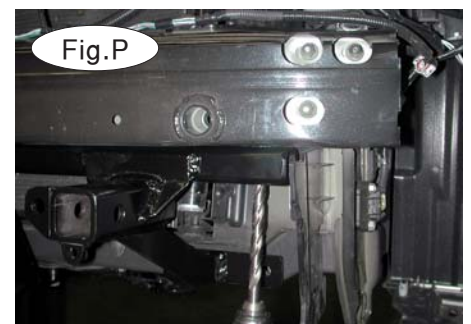
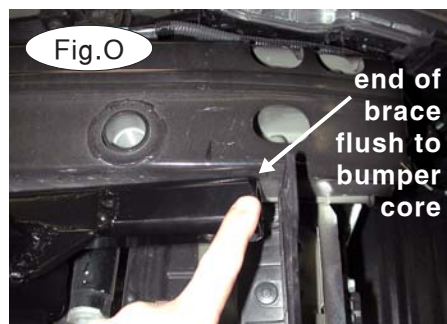

13. Using the pre-drilled holes at both ends of the main receiver brace as templates, drill a 1/2" hole through the first two layers of the bumper core (Fig.P).



BASEPLATE KIT INSTALLATION INSTRUCTIONS

KIT# 1176-1

04/04/05
RV

ROADMASTER, Inc. 6110 NE 127th Ave. Vancouver, WA 98682 1-800-669-9690 fax 360-735-9300 www.roadmasterinc.com

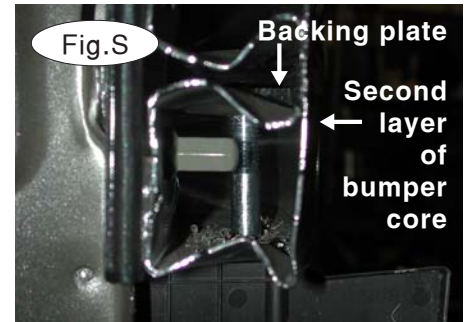
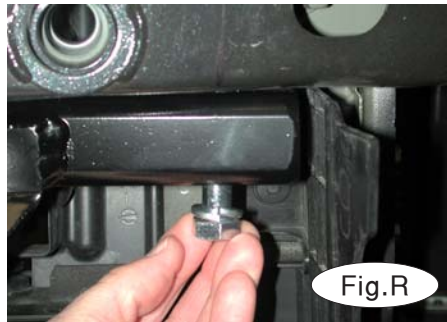

14. At each end, position one of the $\frac{1}{4}$ " x $1\frac{1}{2}$ " x 3" nutted backing plates (with a $\frac{9}{16}$ " hole) directly over the $\frac{1}{2}$ " holes you drilled in the previous step (Fig.Q).

15. Slide a $\frac{1}{2}$ " lock washer over one of the $\frac{1}{2}$ " x 4" bolts and thread the bolt into the backing plate (Fig.R). Repeat for the other side. Tighten both bolts to the torque specifications at the bottom of these instructions. Figure S shows the bolt secured to the backing plate.

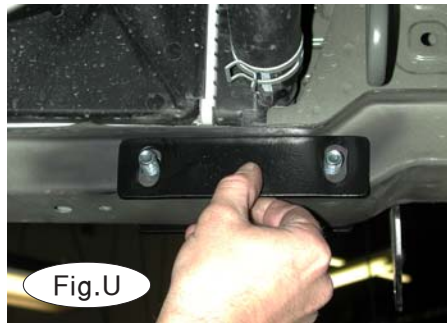
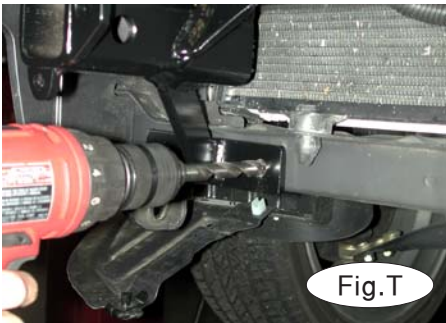

16. Now, attach the bracket to the radiator support – drill two $\frac{1}{2}$ " holes on each side of the bracket through the radiator support, using the two pre-drilled holes in the lower outside braces as templates (Fig.T). Be careful to avoid any hoses or wiring.

17. Position one of the $1\frac{1}{2}$ " x 6" backing plates (with a $\frac{9}{16}$ " x 1" slot) over the two holes you drilled in the previous step (Fig.U). Attach the backing plate with two $\frac{7}{16}$ " x 4" bolts, flat washers, lock washers and nuts. Repeat for the other side.

18. If you moved the tow hook to one side to attach the brace to the motor support (step 8), reattach it – tighten the front bolt and reattach the rear bolt.

19. Torque all bolts to the specifications at the bottom of these instructions.

20. A section of the grille on both sides will have to be trimmed, to accommodate the main brace and the removable front braces. Test fit the fascia and mark the sections to be trimmed, using Figure V as a reference.

21. The left and right splash shields will also have to be trimmed. Use Figure W as a reference.

22. Reattach the fascia and the shock absorption pad, reversing steps 1 through 7.





BASEPLATE KIT INSTALLATION INSTRUCTIONS

KIT# 1176-1

04/04/05
RV

ROADMASTER, Inc. 6110 NE 127th Ave. Vancouver, WA 98682 1-800-669-9690 fax 360-735-9300 www.roadmasterinc.com

23. Ensure that all bolts are torqued to the specifications at the bottom of these instructions.
24. Fit the front bracket arms into the front receiver braces, and secure them in place with the supplied 5/8" draw pins and spring pins.
25. Attach the 8" safety cables with the cable connectors (Q-Links) to the front of the receiver braces (Fig.X).
26. Attach the ends of the safety cables to the tow vehicle's safety cables and tow bar.
27. Install the tow bar to the mounting bracket according to the manufacturer's instructions.



BOLT TORQUE REQUIREMENTS

Note: The torque values represented below are intended as general guidelines. Torque requirements for specific applications may vary. Roadmaster does not warrant this information to be accurate for all applications and disclaims all liability for any claims or damages which may result from its use.

STANDARD BOLTS

Thread Size	Grade	Torque
5/16	5	13 ft./lb.
3/8	5	23 ft./lb.
7/16	5	37 ft./lb.
1/2	5	56 ft./lb.
5/8	5	150 ft./lb.

METRIC BOLTS

Thread Size	Grade	Plated / Unplated
8mm-1.0	8.8	20 ft./lb. 18 ft./lb.
8mm-1.25	8.8	19 ft./lb. 18 ft./lb.
10mm-1.25	8.8	38 ft./lb. 36 ft./lb.
10mm-1.5	8.8	37 ft./lb. 35 ft./lb.

METRIC BOLTS

Thread Size	Grade	Plated / Unplated
12mm-1.25	8.8	70 ft./lb. 65 ft./lb.
12mm-1.5	8.8	66 ft./lb. 61 ft./lb.
12mm-1.75	8.8	65 ft./lb. 60 ft./lb.
14mm-2.0	8.8	104 ft./lb. 97 ft./lb.

All illustrations and specifications contained herein are based on the latest information available at the time of publication approval. ROADMASTER, INC. reserves the right to make changes at any time without notice in material, specification and models or to discontinue models.