



# Installation Instructions

Thank you for purchasing this anti-sway bar kit. Please read through these instructions before installation.

## Rear Anti-Sway Bar Kit for the Freightliner FL Airliner Suspension Forward Mount

part #1209-107  
1½" diameter

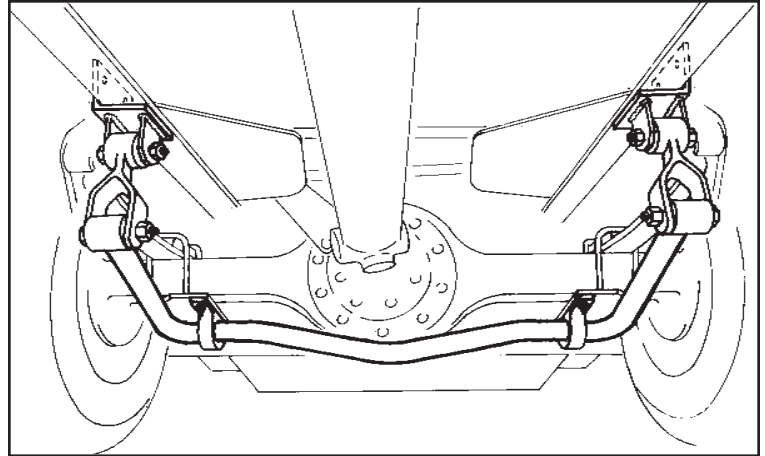

## INTRODUCTION

Thank you for purchasing this anti-sway bar kit. This kit is designed to improve the handling characteristics of your Freightliner FL by reducing the body roll and balancing the weight transfer during cornering. The anti-sway bar kit is engineered for long life and trouble-free performance. For maximum suspension control, use this kit along our front anti-sway bar kit.

All the hardware needed for installation is included in this kit. Refer to the PARTS LIST in these instructions to identify the parts.

## SUGGESTED TOOLS

The following tools are suggested to complete the installation procedures:

- General hand tools
- Wrenches: 5/8", 11/16", 3/4", 15/16"
- Sockets: 5/8", 11/16", 3/4", 15/16"
- Torque wrench

### **⚠ WARNING**

**Failure to follow these instructions can result in property damage, personal injury or even death.**

- If raising the vehicle to install the anti-sway bar, always support the vehicle with jack stands at both frame rails or at the rear axle before working underneath. Ensure that the jack stands are securely positioned, and are rated at or above the weight of the vehicle.
- The installer must read the instructions and use all bolts and parts supplied. Use only the parts supplied by ROADMASTER to install this kit.
- Minor modifications are sometimes necessary due to slight vehicle variations, even for the same year, make and model.
- Regardless of year, make and model, a wide range of options for specific applications may or may not interfere with the installation. It is the installer's responsibility to make certain that equipment is not damaged once the suspension solution travels through the full range of motion. Failure to ensure adequate clearance could result in non-warranty property damage, personal injury or even death.

- If running changes were made by the manufacturer after this kit was designed, there may be weldments, braces, gussets, or other structural items which interfere with the installation. It is the installer's responsibility to allow for these running changes without sacrificing the structural integrity of the anti-sway bar. Failure to securely fasten the anti-sway bar could result in property damage, personal injury or even death.
- ROADMASTER will not be responsible for any damage or injury resulting from any modification or alteration.
- Check ALL the fasteners for tightness before and after road testing the vehicle.
- Do not use this document for custom fabrication, as it may not show all parts or structural components.
- Do not use an air impact wrench when re-installing bolts, as stripped threads may result.
- This anti-sway bar is only warranted for the original installation. Installing a used anti-sway bar on another vehicle is not recommended and will void the warranty.

# PARTS LIST

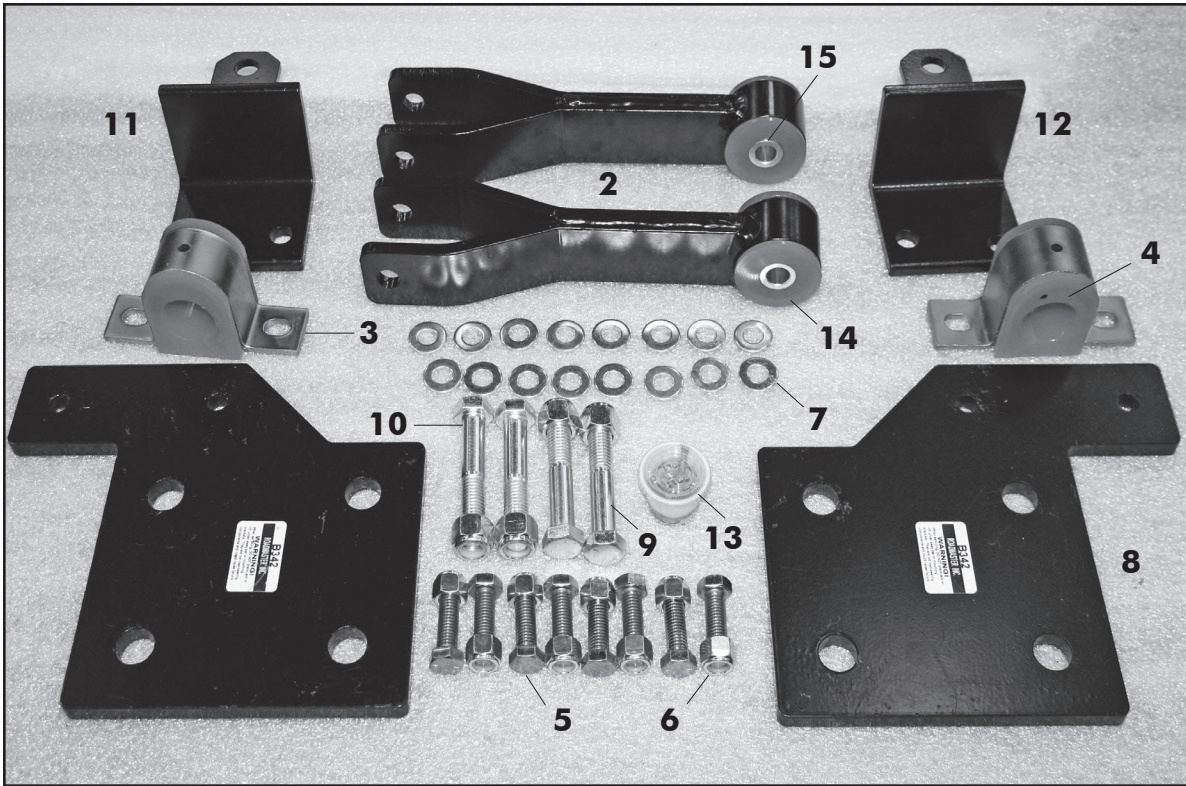

## Part #1209-107

Part #	Description	Qty	Part #	Description	Qty
1. 580090-00*	Anti-sway bar 1-1/2"	1	8. B342	Bracket, axle plate	2
2. B279	Endlink shackle	2	9. 350163-00	Bolt, 5/8" x 3-1/2"	4
3. B141	Bracket, U-clamp	2	10. 350263-00	Nut, 5/8"	4
4. 205217-10	Bushing, split poly	2	11. B272L	Bracket, end link left	1
5. 350096-80	Bolt, 1/2" x 1-3/4"	8	12. B272R	Bracket, end link right	1
6. 350259-00	Locknut, 1/2"	8	13. 400011-30	AQUALUBE Grease	1
7. 350308-20	Washer, 1/2"	16	14. 205202-10	Bushing	8
			15. 205503-00	Metal sleeve	4

\*Not shown

# INSTALLATION

The following instructions must be followed in the order listed to ensure a proper installation and to preserve the ROADMASTER warranty.

1. Apply the parking brake.

The following procedures can be done with the wheels of the vehicle on the ground.

2. Locate the U-bolts holding the springs to the axle.

Remove nuts from U-bolts. Retain original bracket and add a flat plate (B342) with the small holes positioned toward the front and center of the vehicle. Secure with original nuts and washers. Torque to original manufacturer's specifications.

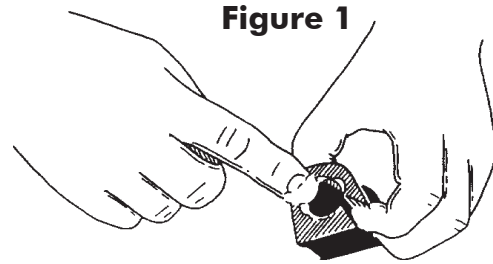
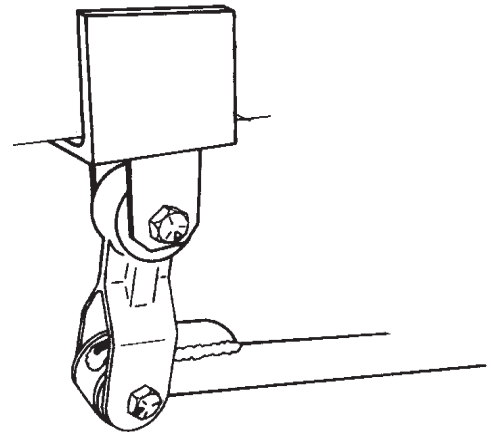

Figure 1

3. Install the saddle brackets and bushings on the anti-sway bar.

Lubricate the inside of the split bushings with the provided lubricant (Figure 1). Install bushings on the anti-sway bar near the arms. Slide the saddle bracket over the split bushings.

Figure 2



4. Install the anti-sway bar assembly to the bottom of flat plates.

Lift the anti-sway bar assembly into position so that the saddle bracket holes align with the flat plate holes. Use the provided bolts (350096-80), washers (350308-20), and nuts (350259-00) to attach. Insert the bolts from the bottom. Tighten to 50 ft./lbs.

Figure 3

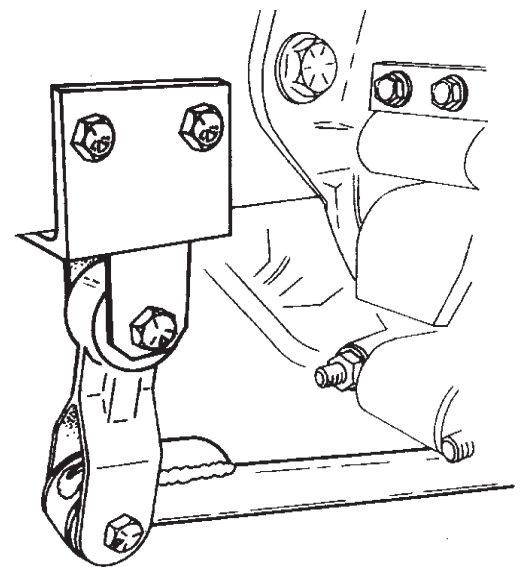

5. Locate the shackles and fasteners.

Attach the shackles (B209) to the anti-sway bar end with the provided bolts (350163-00) and nuts (350263-00). Do not tighten yet (Figure 2).

6. Install the frame brackets to the shackles.

Install the frame bracket to the shackle using the provided bolts (350163-00) and nuts (350263-00). Do not tighten yet.

7. Mark the bracket location with respect to the frame rail.

Hold the bracket up to the frame rail. The location is correct when the shackle is approximately 90 degrees to the frame rail. Mark the bracket and frame for drilling (two holes per side — Figure 3). *Note:* check inside the frame rail for wires, lines, etc., before drilling.

Drill holes and install the brackets using the supplied 1/2" bolts. Tighten to 70 ft./lbs.

# INSTALLATION

8. Tighten the shackle bolts.

Tighten both the upper and lower bolts now to 40-45 ft./lbs. Recheck all fasteners for proper tightness.

9. Test drive and re-inspect the installation.

Listen for any unusual noises.

## WARNING

After road testing, re-check all fasteners for proper tightness — if a fastener has worked loose or fallen off, re-tighten or replace it. Without all kit components properly tightened or in place, the anti-sway bar will not stabilize the vehicle at full capacity, which may cause reduced cornering ability or other reductions in vehicle handling or performance.

Failure to follow these instructions may result in property damage, personal injury or even death.

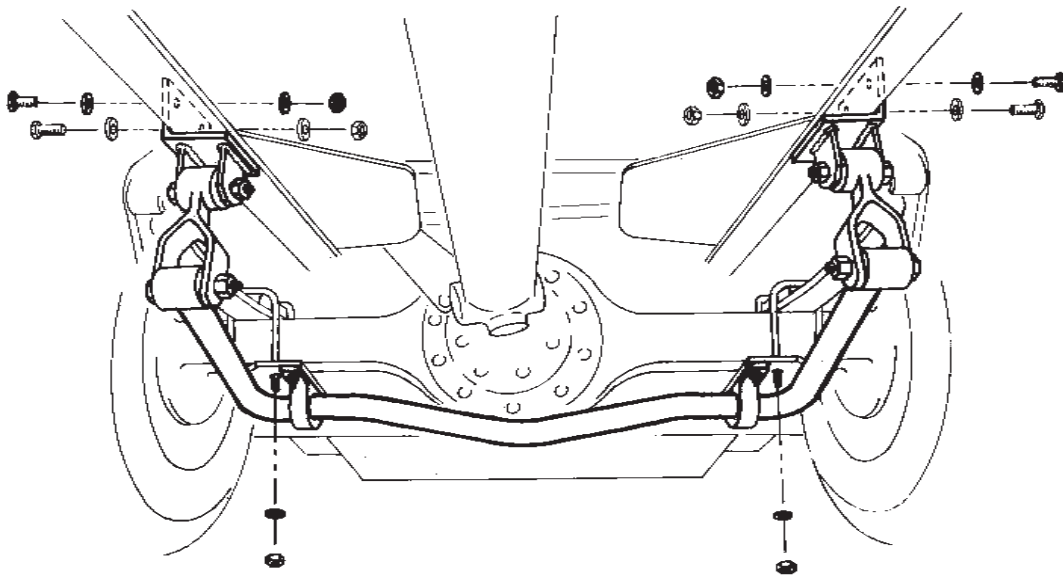

## WARNING

### **The anti-sway bar is not a load-bearing component**

Do not tow or hoist the vehicle using the anti-sway bar or its mounting brackets as attachment points. The anti-sway bar is not designed to carry the weight of the vehicle and may collapse, which will damage the anti-sway bar components, the suspension, or other components. The vehicle will detach or fall, which may cause severe personal injury.

Failure to follow these instructions may result in property damage, personal injury or even death.