



Thank you for purchasing this anti-sway bar kit. Please read through these instructions before installation.

Installation Instructions

Front Anti-Sway Bar Kit for Workhorse W22, Holiday Rambler Vacationer, and Monaco La Palma models

part #1259-105 1-5/8" diameter

Note: Vacationer and La Palma models will also require axle bracket kit #590063-00

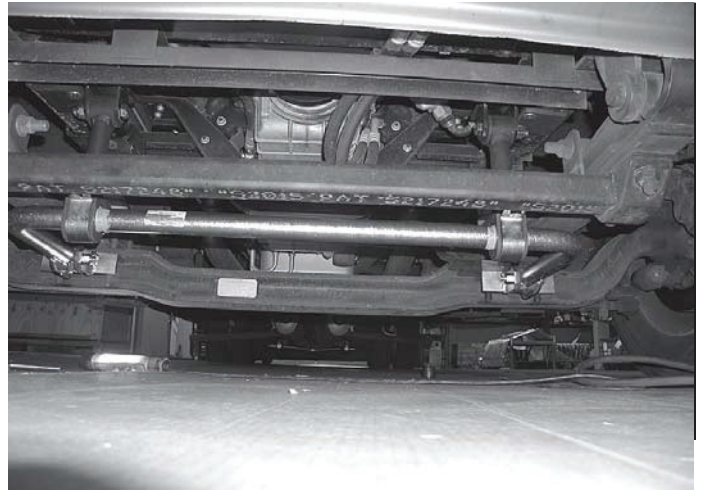

INTRODUCTION

Thank you for purchasing this anti-sway bar kit. This kit is designed to improve the handling characteristics of your Workhorse by reducing the body roll and balancing the weight transfer during cornering. The anti-sway bar kit is engineered for long life and trouble-free performance. For maximum suspension control, use this kit along with our rear anti-sway bar kit.

All the hardware needed for installation is included in this kit. Refer to the PARTS LIST in these instructions to identify the parts.

SUGGESTED TOOLS

The following tools are suggested to complete the installation procedures:

- General hand tools
- 1/8", 1/2" drill bits
- 1/2" drill
- Torque wrench

WARNING

- If raising the vehicle to install the anti-sway bar, always support the vehicle with jack stands at both frame rails or at the rear axle before working underneath. Ensure that the jack stands are securely positioned, and are rated at or above the weight of the vehicle.
- The installer must read the instructions and use all bolts and parts supplied. Use only the parts supplied by ROADMASTER to install this kit.
- Minor modifications are sometimes necessary due to slight vehicle variations, even for the same year, make and model.
- If running changes were made by the manufacturer after this kit was designed, there may be weldments, braces, gussets, or other structural items which interfere with the installation. It is the installer's responsibility to allow for these running changes without sacrificing the structural integrity of the anti-sway bar. Failure to securely fasten the anti-sway bar could result in property damage, personal injury or even death.
- ROADMASTER will not be responsible for any damage or injury resulting from any modification or alteration.
- Check ALL the fasteners for tightness before and after road testing the vehicle.
- Do not use this document for custom fabrication, as it may not show all parts or structural components.
- Do not use an air impact wrench when re-installing bolts, as stripped threads may result.
- This anti-sway bar is only warranted for the original installation. Installing a used anti-sway bar on another vehicle is not recommended and will void the warranty.

WARNING

Failure to follow these instructions can result in property damage, personal injury or even death.

PARTS LIST

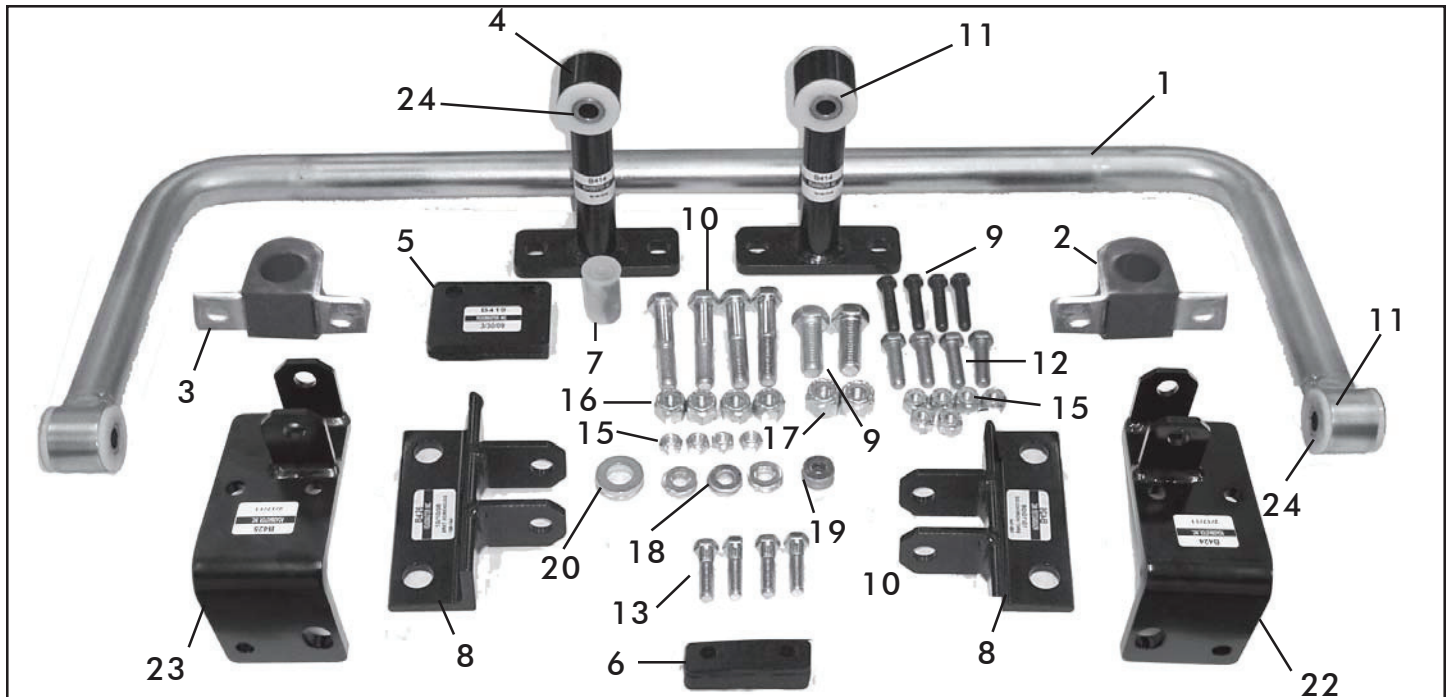

Part #1259-105

Part #	Description	Qty	Part #	Description	Qty
1	580055-00 Anti-sway bar	1	14	350256-02 Locknut, 7/16"	4
2	205222-10 Polybushing	2	15	350259-00 Nut, 1/2"	6
3	B141 U-damp	2	16	350263-00 Locknut, 5/8"	4
4	B414 Droplink W22, front	2	17	350265-00 Locknut, 3/4"	2
5	B419 Bracket clamp W22	2	18	350304-80 Washer, 3/8"	8
6	B423 Bracket shim W22	4	19	350308-20 Washer, 1/2"	12
7	400011-30 Grease AQUALUBE	1	20	350314-20 Washer, 3/4"	4
8	B426 Bracket axle W-22 ft	2	21	*350184-00 3/4" x 3" Bolt	2
9	350096-80 Bolt, 1/2" x 1-3/4" NC	4	22	B424 Bracket frame left	1
10	350163-00 Bolt, 5/8" x 3-1/2"	4	23	B425 Bracket frame right	1
11	205209-00 Polybushing	8	24	205503-00 Metal sleeve	4
12	350097-00 Bolt, 1/2" x 2"	2			
13	350076-80 Bolt, 7/16" x 2"	4			

*not pictured

INSTALLATION

The following instructions must be followed in the order listed to ensure a proper installation and to preserve the ROADMASTER warranty.

1. Install the axle brackets.

Remove the two front U-bolt nuts on each side. Install the B426 axle brackets and reinstall the nuts. Do not tighten at this time (Figure 1). For Vacationer and Lapalma models, install the B701 and B702 at this time.

2. Install the driver's side frame bracket.

Note: for the Workhorse 2007 chassis, the rear steering box has been moved. We have supplied you with a $\frac{3}{4}$ " bolt in place of the 30mm bolt. Drill a $\frac{3}{4}$ " hole and mount the bracket.

Locate and remove the 30mm bolt from the rear steering box bracket inside the driver's side frame rail. Use this bolt to attach the B425 (using front hole) with the tabs closest to front of chassis. Torque the nut back to factory specs. Drill a $\frac{1}{2}$ " hole through the frame rail and install using a $\frac{1}{2}$ " x 2" bolt (350097-00) and secure with a washer and nut. Torque to 80-100 ft.-lbs. Assemble the spacer plate and clamp plate as shown using $\frac{7}{16}$ " bolts, washers and nuts. Tighten the clamp bolts to 40-50 ft.-lbs.

3. Install the passenger side frame bracket.

The passenger side bracket is directly opposite the driver's side bracket. Locate a $\frac{7}{8}$ " hole inside the passenger side frame rail. Install the passenger side frame bracket (B424) inside the frame rail using one $\frac{3}{4}$ " bolt (350386-00); secure with washer and nut. Torque to 80-100 ft.-lbs. Drill a $\frac{1}{2}$ " hole through the frame rail and install the second bolt (350097-00, $\frac{1}{2}$ " x 2"). Secure it with a washer and nut; torque to 80-100 ft.-lbs. Assemble the spacer plate and clamp plate as shown using $\frac{7}{16}$ " bolts, washers and nuts. Tighten the clamp bolts to 40-50 ft.-lbs.(Figure 2).

4. Mount the bar.

Attach anti-sway bar to the axle plates using $\frac{5}{8}$ " bolts (350163-00). Tighten to 30-45 ft.-lbs.(Figure 3).

5. Assemble and connect the drop links.

Install bushings (205209-00) and sleeves (205503-00) into the drop links and attach to the frame brackets on each side. Tighten to 30-45 ft.- lbs.(Figure 4).

6. Connect the anti-sway bar to the drop links.

Lubricate the inside of the anti-sway bar bushings with the provided grease (Figure 5). Install the anti-sway bar bushings and U-clamps on the bar. Connect the anti-sway bar to the drop links using the bolts (350096-80) provided. Torque to 60-75

Figure 1

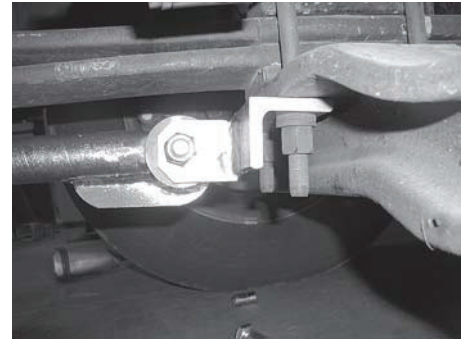

Figure 2

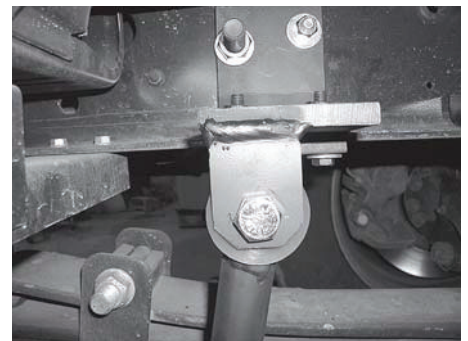

Figure 3



Figure 4

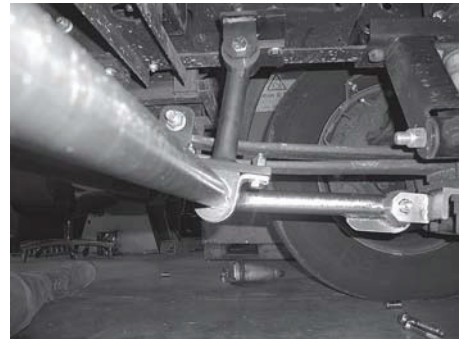
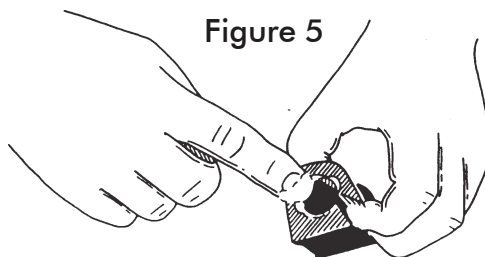

Figure 5



7. Tighten the remaining fasteners.

Tighten the axle clamps to the factory torque specifications.

8. Road test.

Test drive, listen for any unusual noises. Re-inspect installation.

WARNING

After road testing, re-check all fasteners for proper tightness — if a fastener has worked loose or fallen off, re-tighten or replace it. Without all kit components properly tightened or in place, the anti-sway bar will not stabilize the vehicle at full capacity, which may cause reduced cornering ability or other reductions in vehicle handling or performance.

Failure to follow these instructions may result in property damage, personal injury or even death.

WARNING

The anti-sway bar is not a load-bearing component

Do not tow or hoist the vehicle using the anti-sway bar or its mounting brackets as attachment points. The anti-sway bar is not designed to carry the weight of the vehicle and may collapse, which will damage the anti-sway bar components, the suspension, or other components. The vehicle will detach or fall, which may cause severe personal injury.

Failure to follow these instructions may result in property damage, personal injury or even death.