

BASEPLATE KIT INSTALLATION INSTRUCTIONS

ROADMASTER, Inc. 6110 NE 127th Ave. Vancouver, WA 98682 1-800-669-9690 fax 360-735-9300 www.roadmasterinc.com

PARTS LIST:

- 1- FRONT BRACE (A) - Driver's side
- 1- FRONT BRACE (B) - Passenger side
- 1- MAIN BRACE (C) - Driver's side
- 1- MAIN BRACE (D) - Passenger side
- 1- CENTER BRACE (E)

KIT NO. 1419-7

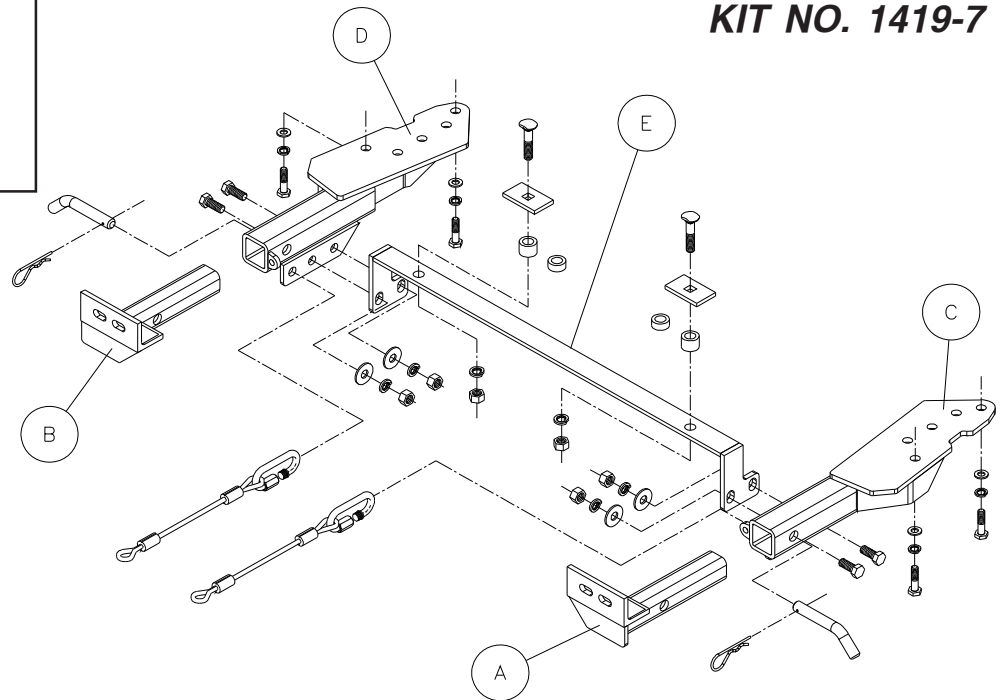

IMPORTANT: All baseplates **must** be assembled with all the bolts left loose for final adjustment and positioning (before tightening) unless otherwise instructed. All bolts **must** be torqued for proper strength. If more than one bolt is used per fastening point, the diagram may only show one. Use flat washers over all slotted holes and lock washers on all fasteners.

WARNING

Failure to heed these warnings or follow the installation instructions may result in a voided warranty, loss of towed vehicle, personal injury or death.

- Do not weld or modify this baseplate or its components. Welding or modification will void the warranty.
- Do not use this document as a basis to design/fabricate a baseplate, as it may not show all parts or structural components.
- We strongly recommend professional installation.
- If the towed vehicle has been in an accident, it must be properly repaired before attaching the baseplate. Do not install the baseplate if any structural frame damage is found.
- The installer must use all bolts and parts supplied. If running changes were made by the vehicle manufacturer after this kit was designed, some bolts or other fasteners may no longer be the correct size. It is the installer's responsibility to verify this kit is securely fastened to the vehicle.
- Use Loctite® Red on all bolts used to secure this baseplate. Torque all bolts to the specifications found at the end of these instructions. Do not over-torque the bolts or failure may occur.
- The installer must inspect the baseplate to ensure adequate clearance, particularly around hoses, air conditioner lines, radiators, etc. or non-warranty failure may result.
- Roadmaster manufactures many styles of baseplates. If your baseplate has removable arms, they must be removed before driving the vehicle, unless the arms can be pinned or padlocked in place. If not secured, the arms could vibrate out.
- Some motorhome chassis have such a tight turning radius that you can damage your motorhome, towed vehicle, tow bar or baseplate while turning sharply. Before getting on the road, test your turning radius in

an empty parking lot. Turning too sharply could result in non-warranty damage to your towing system, motorhome and/or towed vehicle.

- Do not back up with the towed vehicle attached or non-warranty damage will occur to your towing system or vehicles.
- The safety cables must connect the towing vehicle to the towed vehicle frame to frame, with the cables crossed, with enough slack for sharp turns. See cable instructions for proper routing. Failure to do so will result in non-warranty damage and/or the loss of the towed vehicle.
- This kit is designed for use with ROADMASTER tow bars and ROADMASTER adapters only. Using this kit with other brands, without an approved ROADMASTER adapter, may result in non-warranty damage or injury.
- Receiver extensions and out-of-level towing situations of 3 inches or more. This can cause the system to swing much higher and lower, causing excessive strain on the tow bar, baseplate and frame. That can cause the towing system to fail, causing property damage, personal injury or even death. If you must use a receiver extension or drop hitch to tow, it will reduce your receiver's weight capacity by 1/3 to avoid damaging your system. Never use more than one extension and/or drop hitch, as this will void your warranty.
- Every 3,000 miles, the owner must inspect all mounting points for cracks or fatigue, and check the fasteners for proper torque, according to the bolt torque requirements chart on the last page of these instructions.
- The owner must follow the vehicle manufacturer's instructions to prepare the vehicle for towing. Failure to do so may cause severe damage to the vehicle.
- This baseplate is only warranted for the original installation. Installing a used baseplate on another vehicle is not recommended and will void the warranty.

BASEPLATE KIT INSTALLATION INSTRUCTIONS

ROADMASTER, Inc. 6110 NE 127th Ave. Vancouver, WA 98682 1-800-669-9690 fax 360-735-9300 www.roadmasterinc.com

KIT NO. 1419-7

1. **Important:** please use all supplied bolts and parts and read all instructions carefully before beginning this installation. The majority of questions you may have can be answered within the text, and proper installation will ensure safe and secure travel. Now, begin the installation. This bracket kit is one of our XL series which is designed to be partly removable. The kit consists of the two main receiver braces, two front braces, a center brace and a hardware pack. The main receiver brace mounts behind the front bumper fascia and through the lower grille. The center brace inserts between the lower bumper fascia and the radiator between the receiver braces. The front braces install in the receiver braces. Start by laying the kit out according to the illustration. This will give you a visual idea of how the kit installs and also confirm that the kit components are present and accounted for.
2. Start by removing the lower plastic splash shield over the stabilizer bar behind the front bumper. Remove four plastic fasteners on each side then set the splash shield aside. *Note:* loosen the plastic fasteners and twist counter-clockwise to remove. Now, remove three plastic fasteners under the bumper fascia in preparation for a later step.
3. Remove four bolts holding the stabilizer bar to the bottom of the frame (two per side) .
4. Pull down the stabilizer bar and locate a threaded hole in the bottom of the frame just forward and to the outside of the front stabilizer bar bolt mounting hole.
5. Hold the passenger side main brace to the bottom of the frame and bolt through into this hole using a supplied 10mm x 1.5 x 45mm bolt lock washer and fender washer. Align the remaining two holes in the receiver plate to the stabilizer mounting holes and tighten bolt.
6. Repeat step 5 for the driver's side.
7. Bolt the stabilizer bar in place over the receiver braces and leave loose for the time being.
8. Pull the bottom of the front bumper fascia down and insert the center brace behind the bumper fascia between the receiver braces. Bolt to the receiver braces with four 1/2" x 1 1/4" bolts, flat washers, lock washers and nuts.
9. Check the holes in the middle of the center brace and see if they line up with two existing holes in the bottom of the cross member; if not, drill through using the center brace as a guide. Now, fishwire two 1/2" x 2" carriage bolts with narrowed heads and 1/4" x 1 1/2" x 2 1/2" backing plates through the large access holes in back of the cross member into the bottom frame holes. Finish bolting through the center brace with pipe spacers, lock washers and nuts. *Note:* early models will require the use of the 1/2" spacers, while later models will require the 3/4" spacers.
10. Insert the front braces in the receiver braces and secure using 5/8" draw pins and 1/8" spring pins.
11. Tighten all bolts to the torque specifications below.
12. Replace all plastic keepers in the bumper fascia then replace the center splash shield reversing step 2 with the exception of inserting the front plastic keepers into the frame on each side.
13. Install the tow bar according to the manufacturer's instructions and torque all mounting bolts to the specifications below.
14. Attach the ends of the safety cables to the tow vehicle's safety cables and tow bar.

Hardware

- | | |
|---|----------------------|
| 4- 10mm x 1.5 x 45mm bolts | 2- 1/8" spring pins |
| 4- 10mm lock washers | 2- 10" safety cables |
| 4- 10mm fender washers | 2- 5/8" draw pins |
| 4- 1/2" x 1-1/4" bolts | 2- cable connectors |
| 2- 1/2" x 2" carriage bolts with 3/4" heads | 6- 1/2" nuts |
| 6- 1/2" lock washers | 2- 1" x 1/2" spacers |
| 2- 1/4" x 1-1/2" x 2-1/2" sq. hole backing plates | 2- 1" x 3/4" spacers |
| 4- 1/2" flat washers | |

2/20/04

BOLT TORQUE REQUIREMENTS

Note: The torque values represented below are intended as general guidelines. Torque requirements for specific applications may vary. Roadmaster does not warrant this information to be accurate for all applications and disclaims all liability for any claims or damages which may result from its use.

STANDARD BOLTS			METRIC BOLTS			METRIC BOLTS		
Thread Size	Grade	Torque	Thread Size	Grade	Plated/Unplated	Thread Size	Grade	Plated/Unplated
5/16	5	13 ft./lb.	8mm-1.0	8.8	20 ft./lb. 18 ft./lb.	12mm-1.25	8.8	70 ft./lb. 65 ft./lb.
3/8	5	23 ft./lb.	8mm-1.25	8.8	19 ft./lb. 18 ft./lb.	12mm-1.5	8.8	66 ft./lb. 61 ft./lb.
7/16	5	37 ft./lb.	10mm-1.25	8.8	38 ft./lb. 36 ft./lb.	12mm-1.75	8.8	65 ft./lb. 60 ft./lb.
1/2	5	56 ft./lb.	10mm-1.5	8.8	37 ft./lb. 35 ft./lb.	14mm-2.0	8.8	104 ft./lb. 97 ft./lb.
5/8	5	150 ft./lb.						