



MOUNTING BRACKET KIT INSTALLATION INSTRUCTIONS

ROADMASTER, INC.

5602 N.E. SKYPORT WAY

PORTLAND, OR 97218

1-800-669-9690

FAX (503) 288-8900

PARTS LIST:

- 1- MAIN BRACE (A) - Passenger side
- 1- MAIN BRACE (B) - Driver's side
- 1- FRONT BRACE (C) - Passenger side
- 1- FRONT BRACE (D) - Driver's side

KIT NO. 1525-1

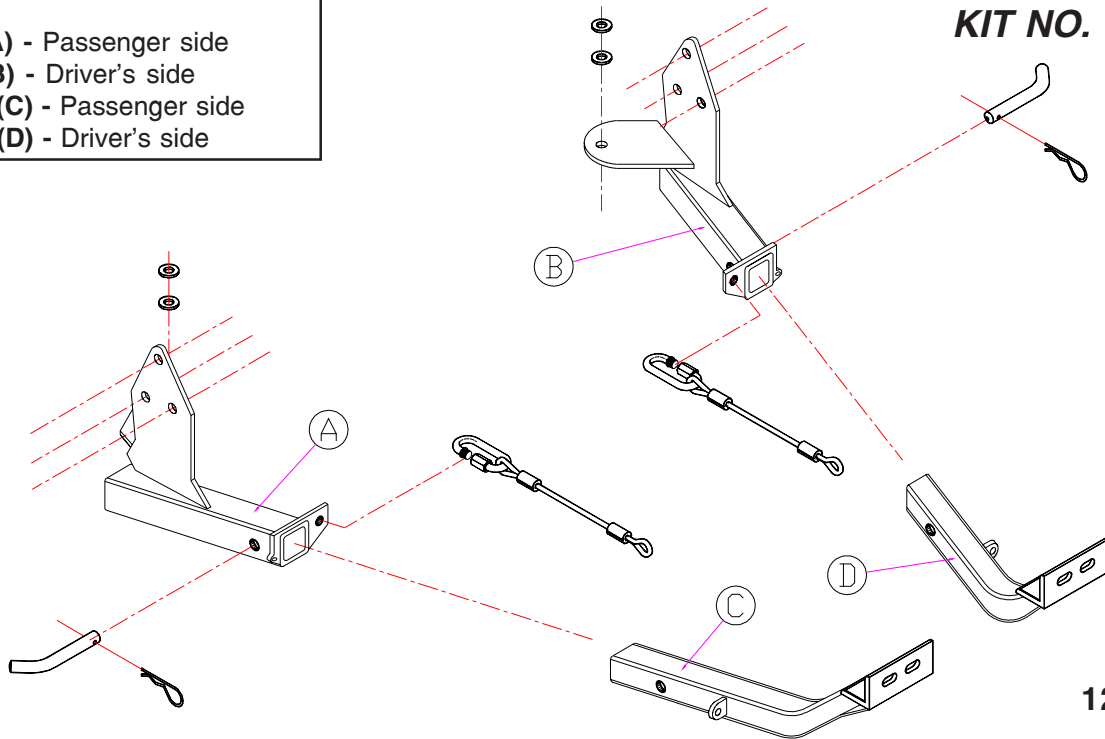

12-09-97

IMPORTANT: All brackets *must* be assembled with all the bolts left loose for final adjustment & positioning (before tightening) unless otherwise instructed. All bolts *must* be torqued for proper strength. If more than one bolt is used per fastening point, the diagram may only show one.

- Use flat washers over all slotted holes
- Use lock washers on all fasteners

ROADMASTER Limited Warranty, including One-Year Conditional Warranty Text and Product Registration Card, in Carton.

WARNING

- Do not use this document for custom fabrication as it may not show all parts or structural components.
- ROADMASTER will not be responsible for any damage or injury resulting from any modification or alteration.
- The owner must inspect all mounts and brackets before each use for cracks or other signs of fatigue. Also, inspect the fasteners for proper torque, according to the torque chart.
- The owner must check the manufacturer's instructions for the proper procedure(s) to prepare the vehicle for towing. Some vehicles must be equipped with a transmission lube pump, an axle disconnect, driveline disconnect or free-wheeling hubs before they can be towed. Failure to properly equip the vehicle will cause severe damage to the transmission.
- The installer must read the instructions and use all bolts and parts supplied.
- If the towed vehicle has been in an accident, it must be properly repaired before attaching the brackets. Do not install the brackets if any structural frame damage is found. Failure to repair the damage may result in loss of your towed vehicle.
- Some motorhome chassis have such a tight turning radius that you can damage your motorhome, towed vehicle or tow bar while turning sharply. Before getting on the road, test your turning radius in an empty parking lot. Damage that results from turning too sharply is not covered by warranty.
- The driver must not back up the motorhome with the towed vehicle attached or non-warranty damage will occur to your towing system or towed vehicle.
- The safety cables must connect the towing vehicle to the towed vehicle frame to frame, with the cables crossed. Refer to the cable instructions for proper routing.
- Make sure there is enough slack in the safety cables at the motorhome to allow for sharp turns.
- Use caution when handling the tow bar — if your hands, fingers or any part of your body are caught between moving components, they can be pinched, cut or otherwise injured.
- This bracket is designed for use with ROADMASTER tow bars and ROADMASTER adaptors. Using this bracket with other brands, without an approved ROADMASTER adaptor, may result in non-warranty damage or injury.
- Important! This bracket is only warranted for the original installation. Installing a used bracket on another vehicle is not recommended and will void the warranty.
- Upon final installation, the installer must inspect the bracket to ensure adequate clearance, particularly around hoses, AC lines, radiators, etc., or non-warranty damage will result.

**WARNING**

Failure to follow these instructions can result in property damage, personal injury or even death.

MOUNTING BRACKET KIT INSTALLATION INSTRUCTIONS

ROADMASTER, INC. 5602 N.E. SKYPORT WAY PORTLAND, OR 97218 1-800-669-9690 FAX (503) 288-8900

KIT NO. 1525-1

1. This bracket kit is one of our XL Series which consists of two receiver braces, two removable front braces and a hardware packet. It utilizes the tie down plate mounts and the suspension mount bolt on each side of the frame. Remove the lower splash shield; then start on the passenger side by removing the tie down plate. Save the bolts and work on one side at a time.
2. Remove one bolt (only) from the suspension sub frame. Now, bolt through the rear of the lower receiver and receiver and two 1/2" flat washers with the same bolt. NOTE: The flat washers are needed as shims, do not omit. Tighten the bolt to pull the receiver brace up into position, then bolt to the side of the frame using the original three tie down bolts. Do not tighten at this time.
3. The remaining driver side is the same with the exception that a air plenum must be removed to gain access to the tie down bolts. Three bolts must be removed and the plenum dropped temporarily before proceeding as in step two.
4. Insert the upper braces into the receivers and pin in place with the supplied 5/8" draw pin.
5. Mount the tow bar according to the manufacturers instructions and align the bar and braces.
6. When satisfactory, tighten all bolts to the torque specifications below.
7. Recheck the installation and be sure all bolts are tight, replace the air plenum and splash shield. Now, use the provided cable connectors to install the provided safety cables between the lower RECEIVER BRACES and the tow VEHICLES SAFETY CABLES. NOTE: This XL bracket has been designed to enhance the convenience of our quick disconnect bar. Other types of bars may require that the bar itself be removed before removing the upper braces from the receivers.

HARDWARE LIST:

- 4-1/2" FLAT WASHERS
- 2-5/8" RECEIVER PINS
- 2-1/8" SPRING PINS
- 2-13" SAFETY CABLES
- 2-CABLE CONNECTORS

12-09-97

CAUTION: Installer must read instructions and use all bolts and parts supplied.

FAILURE TO FOLLOW THESE INSTRUCTIONS CAN RESULT IN DEATH, PERSONAL INJURY OR PROPERTY DAMAGE

BOLT TORQUE REQUIREMENTS

Note: The torque values represented below are intended as general guidelines. Torque requirements for specific applications may vary. Roadmaster does not warrant this information to be accurate for all applications and disclaims all liability for any claims or damages which may result from its use.

STANDARD BOLTS			METRIC BOLTS			METRIC BOLTS		
Thread Size	Grade	Torque	Thread Size	Grade	Plated/Unplated	Thread Size	Grade	Plated/Unplated
5/16	5	13 ft./lb.	8mm-1.0	8.8	20 ft./lb. 18 ft./lb.	12mm-1.25	8.8	70 ft./lb. 65 ft./lb.
3/8	5	23 ft./lb.	8mm-1.25	8.8	19 ft./lb. 18 ft./lb.	12mm-1.5	8.8	66 ft./lb. 61 ft./lb.
7/16	5	37 ft./lb.	10mm-1.25	8.8	38 ft./lb. 36 ft./lb.	12mm-1.75	8.8	65 ft./lb. 60 ft./lb.
1/2	5	56 ft./lb.	10mm-1.5	8.8	37 ft./lb. 35 ft./lb.	14mm-2.0	8.8	104 ft./lb. 97 ft./lb.
5/8	5	150 ft./lb.						

All illustrations and specifications contained herein are based on the latest information available at the time of publication approval. ROADMASTER, INC. reserves the right to make changes at any time without notice in material, specification and models or to discontinue models.