



MOUNTING BRACKET KIT INSTALLATION INSTRUCTIONS

ROADMASTER, Inc. 6110 NE 127th Ave. Vancouver, WA 98682 1-800-669-9690 fax 360-735-9300 www.roadmasterinc.com

PARTS LIST:

- 1- RECEIVER BRACE (A) - Passenger side
- 1- RECEIVER BRACE (B) - Driver's side
- 1- FRONT BRACE (C) - Passenger side
- 1- FRONT BRACE (D) - Driver's side

KIT NO. 1531-1

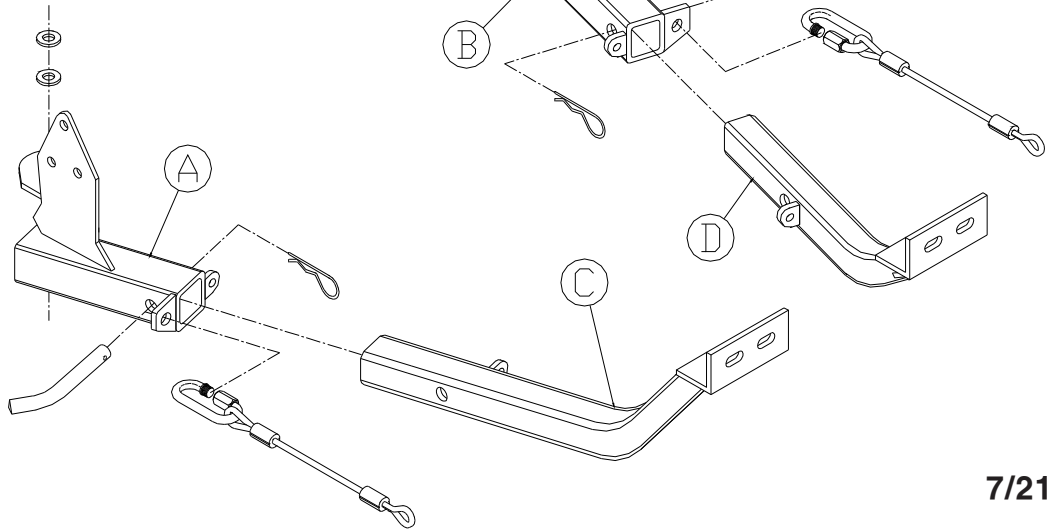

7/21/99

IMPORTANT: All brackets **must** be assembled with all the bolts left loose for final adjustment and positioning (before tightening) unless otherwise instructed. All bolts **must** be torqued for proper strength. If more than one bolt is used per fastening point, the diagram may only show one.

- Use flat washers over all slotted holes
- Use lock washers on all fasteners

ROADMASTER Limited Warranty, including One-Year Conditional Warranty Text and Product Registration Card, in Carton.

⚠ WARNING

Failure to follow these instructions can result in property damage, personal injury or even death.

- Installation of most mounting brackets requires moderate mechanical aptitude and skills. We strongly recommend professional installation by an experienced installer.
- The installer must read the instructions and use all bolts and parts supplied. Failure to securely fasten the bracket could result in loss of the towed vehicle.
- Do not use this document for custom fabrication, as it may not show all parts or structural components. Custom fabrication or an attempt to copy this bracket design could result in loss of the towed vehicle.
- The owner must inspect all mounts and brackets before each use for cracks or other signs of fatigue. Also, inspect the fasteners for proper torque, according to the bolt torque requirements chart on the last page. Failure to do so could result in loss of the towed vehicle.
- The owner must check the vehicle manufacturer's instructions for the proper procedure(s) to prepare the vehicle for towing. Some vehicles must be equipped with a transmission lube pump, an axle disconnect, driveline disconnect or free-wheeling hubs before they can be towed. Failure to properly equip the vehicle will cause severe damage to the transmission.
- If running changes were made by the vehicle manufacturer after this bracket was designed, some bolts or other fasteners in the included hardware pack may no longer be the correct size. It is the installer's responsibility to verify that the bracket is securely fastened to the vehicle, and fitted with the correct hardware, to account for these changes. Failure to

securely fasten the bracket could result in loss of the towed vehicle.

- If the towed vehicle has been in an accident, it must be properly repaired before attaching the bracket. **Do not install the bracket if any structural frame damage is found.** Failure to repair the damage could result in the loss of the towed vehicle.
- Some motorhome chassis have such a tight turning radius that you can damage your motorhome, towed vehicle, tow bar or bracket while turning sharply. **Before getting on the road, test your turning radius in an empty parking lot.** Turning too sharply could result in non-warranty damage to towing system, motorhome and/or towed vehicle.
- Do not back up with the towed vehicle attached or non-warranty damage will occur to your towing system, motorhome and/or towed vehicle.
- The safety cables must connect the towing vehicle to the towed vehicle frame to frame, with the cables crossed, with enough slack for sharp turns. Refer to the cable instructions for proper routing. Failure to leave enough slack in the safety cables, or failure to connect the safety cables frame to frame, will result in the loss of the towed vehicle.
- This bracket is designed for use with ROADMASTER tow bars and ROADMASTER adaptors only. **Using this bracket with other brands, without an approved ROADMASTER adaptor, may result in non-warranty damage or injury.**
- Upon final installation, the installer must inspect the bracket to ensure adequate clearance, particularly around hoses, air conditioner lines, radiators, etc., or non-warranty damage to the towed vehicle will result.
- This bracket is only warranted for the original installation. Installing a used bracket on another vehicle is not recommended and will void the warranty.

MOUNTING BRACKET KIT INSTALLATION INSTRUCTIONS

ROADMASTER, Inc. 6110 NE 127th Ave. Vancouver, WA 98682 1-800-669-9690 fax 360-735-9300 www.roadmasterinc.com

KIT NO. 1531-1

- Important:** please use all supplied bolts and parts and read all instructions carefully before beginning this installation. The majority of questions you may have can be answered within the text, and proper installation will ensure safe and secure travel. Now, begin the installation. This bracket kit is one of our XL Series which consists of two receiver braces, two removable front braces and a hardware packet. It utilizes the tie down plate mounts and the suspension mount bolt on each side of the frame. Remove the lower splash shield; you must remove three 10mm bolts holding the air plenum on the passenger side, then remove the air plenum. Remove the tie down plates. Save the bolts and work on one side at a time.
- Remove one bolt (only) from the suspension sub frame. Now, bolt through the rear of the lower receiver and two 1/2" flat washers with the same bolt. *Note:* the flat washers are needed as shims, do not omit. Tighten the bolt to pull the receiver brace up into position, then bolt to the side of the frame using the original three tie down bolts. Do not tighten at this time.
- The remaining driver side is the same with the exception that the evaporation canister must be removed. Remove the four 10mm bolts holding the evaporation canister, then hold to one side while removing the tie down bolts.
- Insert the upper braces into the receivers and pin in place with the supplied 5/8" draw pins and 1/8" spring pins.
- Mount the tow bar according to the manufacturers instructions and align the bar and braces.
- When satisfactory, tighten all bolts to the torque specifications below.
- Recheck the installation and be sure all bolts are tight, replace the air plenum and splash shield. Now use the provided cable connectors to install the provided safety cables between the lower receiver braces and the tow vehicle's safety cables.
- Note:* this XL bracket has been designed to enhance the convenience of our quick disconnect bar. Other types of bars may require that the bar itself be removed before removing the upper braces from the receivers.

HARDWARE LIST:

- 4-1/2" FLAT WASHERS
- 2-5/8" DRAW PINS
- 2-1/8" DRAW PINS
- 2-15" SAFETY CABLES
- 2-CABLE CONNECTORS

7/21/99

BOLT TORQUE REQUIREMENTS

Note: The torque values represented below are intended as general guidelines. Torque requirements for specific applications may vary. Roadmaster does not warrant this information to be accurate for all applications and disclaims all liability for any claims or damages which may result from its use.

STANDARD BOLTS			METRIC BOLTS			METRIC BOLTS		
Thread Size	Grade	Torque	Thread Size	Grade	Plated/Unplated	Thread Size	Grade	Plated/Unplated
5/16	5	13 ft./lb.	8mm-1.0	8.8	20 ft./lb. 18 ft./lb.	12mm-1.25	8.8	70 ft./lb. 65 ft./lb.
3/8	5	23 ft./lb.	8mm-1.25	8.8	19 ft./lb. 18 ft./lb.	12mm-1.5	8.8	66 ft./lb. 61 ft./lb.
7/16	5	37 ft./lb.	10mm-1.25	8.8	38 ft./lb. 36 ft./lb.	12mm-1.75	8.8	65 ft./lb. 60 ft./lb.
1/2	5	56 ft./lb.	10mm-1.5	8.8	37 ft./lb. 35 ft./lb.	14mm-2.0	8.8	104 ft./lb. 97 ft./lb.
5/8	5	150 ft./lb.						

All illustrations and specifications contained herein are based on the latest information available at the time of publication approval. ROADMASTER, INC. reserves the right to make changes at any time without notice in material, specification and models or to discontinue models.