



MOUNTING BRACKET KIT INSTALLATION INSTRUCTIONS

ROADMASTER, Inc.

6110 NE 127th Ave.

Vancouver, WA 98682

1-800-669-9690

www.roadmasterinc.com

PARTS LIST:

- 1- FRONT BRACE (A) - Passenger side
- 1- FRONT BRACE (B) - Driver's side
- 1- REAR BRACE (C) - Passenger side
- 1- REAR BRACE (D) - Driver's side

KIT NO. 1532-1

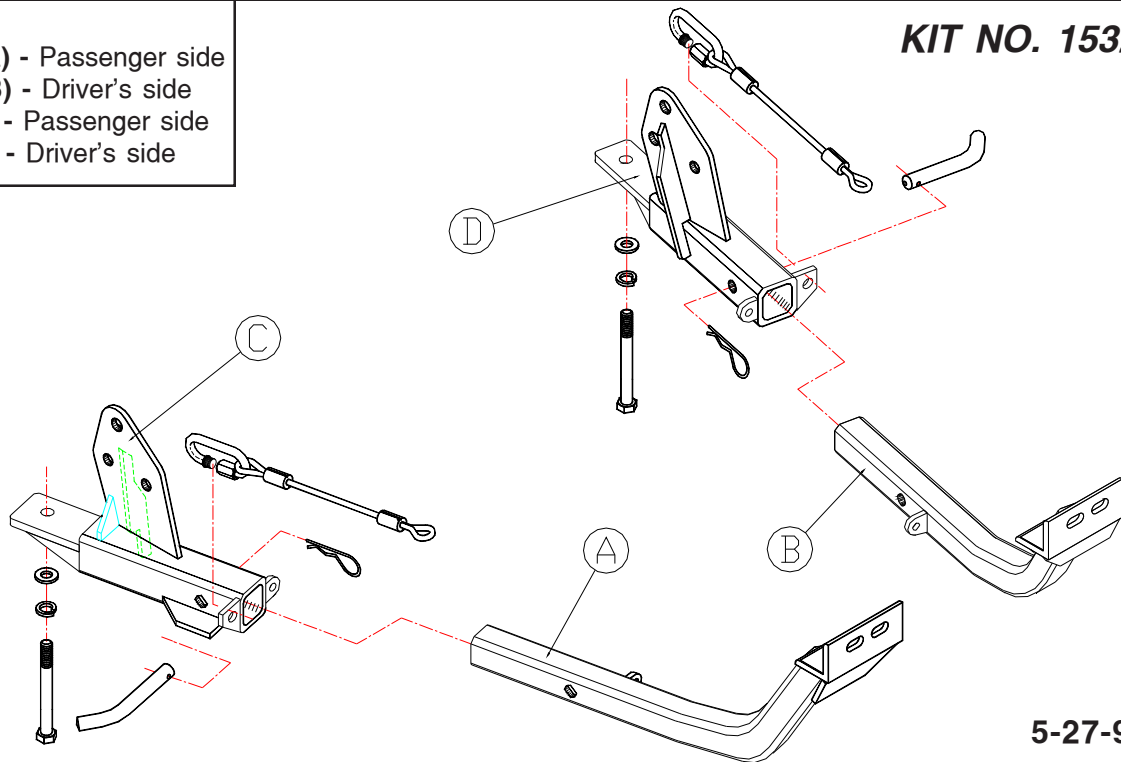

5-27-98

IMPORTANT: All brackets **must** be assembled with all the bolts left loose for final adjustment and positioning (before tightening) unless otherwise instructed. All bolts **must** be torqued for proper strength. If more than one bolt is used per fastening point, the diagram may only show one.

- Use flat washers over all slotted holes
- Use lock washers on all fasteners

ROADMASTER Limited Warranty, including One-Year Conditional Warranty Text and Product Registration Card, in Carton.

WARNING

- Do not use this document for custom fabrication, as it may not show all parts or structural components. Custom fabrication or an attempt to copy this bracket design could result in loss of the towed vehicle.
- The owner must inspect all mounts and brackets before each use for cracks or other signs of fatigue. Also, inspect the fasteners for proper torque, according to the bolt torque requirements chart on the last page. Failure to do so could result in loss of the towed vehicle.
- The owner must check the manufacturer's instructions for the proper procedure(s) to prepare the vehicle for towing. Some vehicles must be equipped with a transmission lube pump, an axle disconnect, driveline disconnect or free-wheeling hubs before they can be towed. Failure to properly equip the vehicle will cause severe damage to the transmission.
- The installer must read the instructions and use all bolts and parts supplied. Failure to securely fasten the bracket could result in loss of the towed vehicle.
- If running changes were made by the vehicle manufacturer after this bracket was designed, some bolts or other fasteners in the included hardware pack may no longer be the correct size. It is the installer's responsibility to verify that the bracket is securely fastened to the vehicle, and fitted with the correct hardware, to account for these changes. Failure to securely fasten the bracket could result in loss of the towed vehicle.
- If the towed vehicle has been in an accident, it must be properly repaired before attaching the bracket. Do not install the bracket if any structural frame damage is found. Failure to repair the damage may result in the loss of the towed vehicle.
- Some motorhome chassis have such a tight turning radius that you can damage your motorhome, towed vehicle, tow bar or bracket while turning sharply. Before getting on the road, test your turning radius in an empty parking lot. Turning too sharply could result in non-warranty damage to towing system, motorhome and/or towed vehicle.
- Do not back up with the towed vehicle attached or non-warranty damage will occur to your towing system, motorhome and/or towed vehicle.
- The safety cables must connect the towing vehicle to the towed vehicle frame to frame, with the cables crossed, with enough slack for sharp turns. Refer to the cable instructions for proper routing. Failure to leave enough slack in the safety cables, or failure to connect the safety cables frame to frame, will result in the loss of the towed vehicle.
- This bracket is designed for use with ROADMASTER tow bars and ROADMASTER adaptors only. Using this bracket with other brands, without an approved ROADMASTER adaptor, may result in non-warranty damage or injury.
- Upon final installation, the installer must inspect the bracket to ensure adequate clearance, particularly around hoses, air conditioner lines, radiators, etc., or non-warranty damage to the towed vehicle will result.
- This bracket is only warranted for the original installation. Installing a used bracket on another vehicle is not recommended and will void the warranty.

WARNING

Failure to follow these instructions can result in property damage, personal injury or even death.

MOUNTING BRACKET KIT INSTALLATION INSTRUCTIONS

ROADMASTER, Inc. 6110 NE 127th Ave. Vancouver, WA 98682 1-800-669-9690 www.roadmasterinc.com

KIT NO. 1532-1

1. This bracket kit utilizes the tie down plate mounts and the front suspension mount bolt on each side of the frame. Prepare to mount the braces by removing the lower front splash guard.
2. Remove the exposed tie down plates and save the bolts.
3. Remove the front bolts (only) from the suspension subframe. Now, bolt through the rear of the lower receivers with the supplied 12mm x 1.25 x 140mm bolts. Tighten the bolts to pull the braces up into position, then bolt to the side of the frame using the original six tie down bolts. Do not tighten at this time. *Note:* on vehicles with rear air conditioning, a small air conditioner canister may be located in close proximity to the passenger side tie down plate mount. If this is the case, temporarily remove two small screws holding the canister and displace to one side slightly to mount the brace, then reinstall the screws.
4. Insert the upper braces into the receivers and pin in place.
5. Mount the tow bar according to the manufacturer's instructions and align the bar and braces.
6. Use the provided cable connectors to install the provided safety cables between the lower receiver braces and the tow vehicle's safety cables.
7. Trim the splash guard to fit and replace. *Note:* this XL series bracket has been designed to enhance the convenience of our quick disconnect bar. Other types of bars may require that the bar itself be removed before removing the upper braces from the receivers.

HARDWARE LIST:

- 2-12MM X 1.25 X 140MM BOLTS
- 2-12MM FLAT WASHERS
- 2-12MM LOCK WASHERS
- 2-5/8" RECEIVER PINS
- 2-1/8" SPRING PINS
- 2-19" SAFETY CABLES
- 2-CABLE CONNECTORS

5-27-98

CAUTION: Installer must read instructions and use all bolts and parts supplied.

FAILURE TO FOLLOW THESE INSTRUCTIONS CAN RESULT IN DEATH, PERSONAL INJURY OR PROPERTY DAMAGE

BOLT TORQUE REQUIREMENTS

Note: The torque values represented below are intended as general guidelines. Torque requirements for specific applications may vary. Roadmaster does not warrant this information to be accurate for all applications and disclaims all liability for any claims or damages which may result from its use.

STANDARD BOLTS			METRIC BOLTS			METRIC BOLTS		
Thread Size	Grade	Torque	Thread Size	Grade	Plated/Unplated	Thread Size	Grade	Plated/Unplated
5/16	5	13 ft./lb.	8mm-1.0	8.8	20 ft./lb. 18 ft./lb.	12mm-1.25	8.8	70 ft./lb. 65 ft./lb.
3/8	5	23 ft./lb.	8mm-1.25	8.8	19 ft./lb. 18 ft./lb.	12mm-1.5	8.8	66 ft./lb. 61 ft./lb.
7/16	5	37 ft./lb.	10mm-1.25	8.8	38 ft./lb. 36 ft./lb.	12mm-1.75	8.8	65 ft./lb. 60 ft./lb.
1/2	5	56 ft./lb.	10mm-1.5	8.8	37 ft./lb. 35 ft./lb.	14mm-2.0	8.8	104 ft./lb. 97 ft./lb.
5/8	5	150 ft./lb.						

All illustrations and specifications contained herein are based on the latest information available at the time of publication approval. ROADMASTER, INC. reserves the right to make changes at any time without notice in material, specification and models or to discontinue models.