

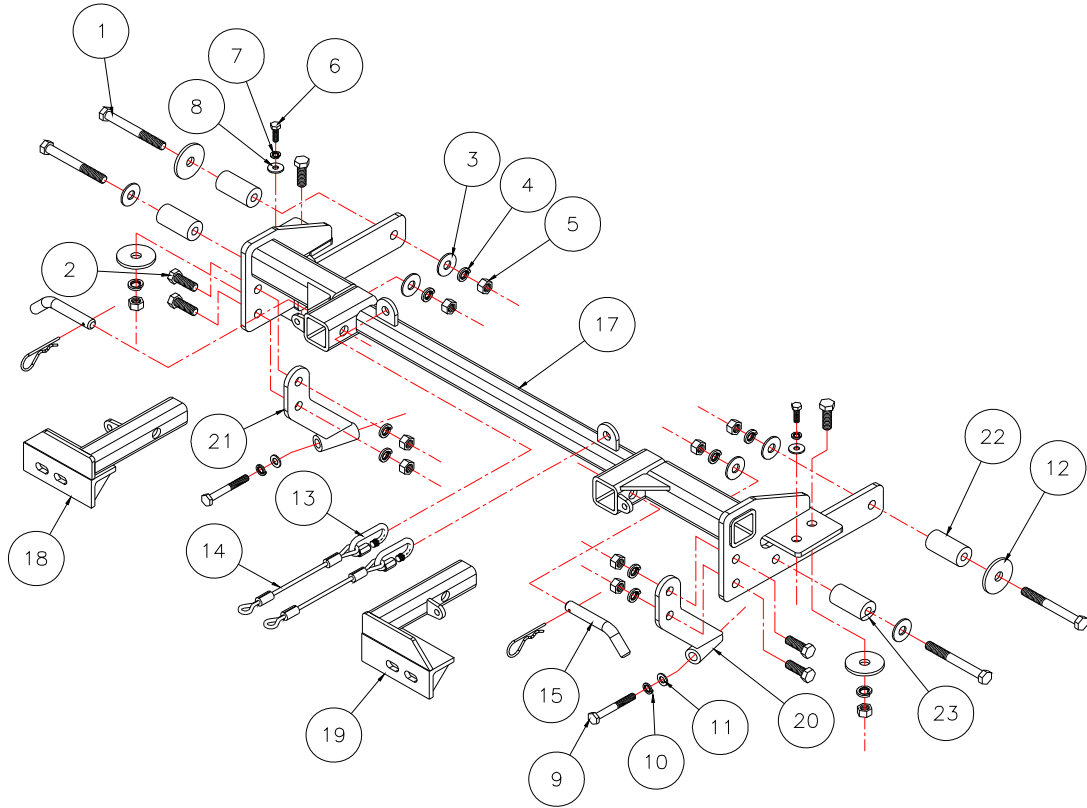

MOUNTING BRACKET KIT INSTALLATION INSTRUCTIONS

KIT# 1544-1
03/26/08
KS

ROADMASTER, Inc. 6110 NE 127th Ave. Vancouver, WA 98682 1-800-669-9690 fax 360-735-9300 www.roadmasterinc.com



Item	Qty.	Length	Width	Description	Part#
1	4	4 1/2"	1/2"	BOLT	350106-00
2	6	1 1/2"	1/2"	BOLT	350095-00
3	6		1/2"	FLAT WASHER	350308-00
4	10		1/2"	LOCK WASHER	350309-00
5	10		1/2"	NUT	350258-00
6	2	25MM	8mm	8mm x 1.25 x 25mm BOLT	356008-00
7	2		8mm	LOCK WASHER	355705-00
8	2		8mm	FENDER WASHER	355702-00
9	2	80MM	10mm	10mm x 1.25 x 80mm BOLT	356214-00
10	2		10mm	LOCK WASHER	355715-00
11	2		10mm	FLAT WASHER	355710-00
12	4		1/2"	PLATE WASHER	350351-00
13	2			CONNECTOR	200008-00
14	2	10"		10" SAFETY CABLES	500646-10
15	4			DRAW PIN / SPRING PIN	357035-00
16	2			ZIP TIES BLACK	300140-10
17	1			MAIN BRACE WELDMENT	C-000433
18	1			PASSENGER SIDE ARM WELDMENT	C-000434
19	1			DRIVER SIDE ARM WELDMENT	C-000435
20	1			DRIVER SIDE LOWER BRACE WELDMENT	C-000436
21	1			PASSENGER SIDE LOWER BRACE WELDMENT	C-000437
22	2			2 3/8" TUBE SPACER	A-000794
23	2			2 3/8" TUBE SPACER WITH BEVEL	A-000799



MOUNTING BRACKET KIT INSTALLATION INSTRUCTIONS

KIT# 1544-1
03/26/08
KS

ROADMASTER, Inc. 6110 NE 127th Ave. Vancouver, WA 98682 1-800-669-9690 fax 360-735-9300 www.roadmasterinc.com

This bracket kit is one of our XL series, which allows the visible front portion of the brackets to be easily removed from the front of the vehicle (Fig.A and B). The kit consists of the main receiver brace, two front arm braces, two lower braces and a hardware pack. The main receiver brace mounts behind the front bumper fascia to the inside of the frame. The lower braces attach to the front of the radiator support on each side. The front arm braces insert into the receivers on each side.

Before starting the installation, lay out the kit components in order, starting with step 1. This will give you a visual idea of how the kit installs, and will also confirm that all the components are present and accounted for.



IMPORTANT: All brackets **must** be assembled with all the bolts left loose for final adjustment and positioning (before tightening) unless otherwise instructed. All bolts **must** be torqued for proper strength. If more than one bolt is used per fastening point, the diagram may only show one.

- Use flat washers over all slotted holes
- Use lock washers on all fasteners

ROADMASTER Limited Warranty, including One-Year Conditional Warranty Text and Product Registration Card, in Carton.

WARNING

- Do not use this document for custom fabrication, as it may not show all parts or structural components. Custom fabrication or an attempt to copy this bracket design could result in loss of the towed vehicle.
- The owner must inspect all mounts and brackets before each use for cracks or other signs of fatigue. Also, inspect the fasteners for proper torque, according to the bolt torque requirements chart on the last page. Failure to do so could result in loss of the towed vehicle.
- The owner must check the manufacturer's instructions for the proper procedure(s) to prepare the vehicle for towing. Some vehicles must be equipped with a transmission lube pump, an axle disconnect, driveline disconnect or free-wheeling hubs before they can be towed. Failure to properly equip the vehicle will cause severe damage to the transmission.
- The installer must read the instructions and use all bolts and parts supplied. Failure to securely fasten the bracket could result in loss of the towed vehicle.
- If running changes were made by the vehicle manufacturer after this bracket was designed, some bolts or other fasteners in the included hardware pack may no longer be the correct size. It is the installer's responsibility to verify that the bracket is securely fastened to the vehicle, and fitted with the correct hardware, to account for these changes. Failure to securely fasten the bracket could result in loss of the towed vehicle.
- If the towed vehicle has been in an accident, it must be properly repaired before attaching the bracket. Do not install the bracket if any structural frame damage is found. Failure to repair the damage may result in the loss of the towed vehicle.

- Some motorhome chassis have such a tight turning radius that you can damage your motorhome, towed vehicle, tow bar or bracket while turning sharply. Before getting on the road, test your turning radius in an empty parking lot. Turning too sharply could result in non-warranty damage to towing system, motorhome and/or towed vehicle.
- Do not back up with the towed vehicle attached or non-warranty damage will occur to your towing system, motorhome and/or towed vehicle.
- The safety cables must connect the towing vehicle to the towed vehicle frame to frame, with the cables crossed, with enough slack for sharp turns. Refer to the cable instructions for proper routing. Failure to leave enough slack in the safety cables, or failure to connect the safety cables frame to frame, will result in the loss of the towed vehicle.
- This bracket is designed for use with ROADMASTER tow bars and ROADMASTER adaptors only. Using this bracket with other brands, without an approved ROADMASTER adaptor, may result in non-warranty damage or injury.
- Upon final installation, the installer must inspect the bracket to ensure adequate clearance, particularly around hoses, air conditioner lines, radiators, etc., or non-warranty damage to the towed vehicle will result.
- This bracket is only warranted for the original installation. Installing a used bracket on another vehicle is not recommended and will void the warranty.

WARNING

Failure to follow these instructions can result in property damage, personal injury or even death.



MOUNTING BRACKET KIT INSTALLATION INSTRUCTIONS

KIT# 1544-1
03/26/08
KS

ROADMASTER, Inc. 6110 NE 127th Ave. Vancouver, WA 98682 1-800-669-9690 fax 360-735-9300 www.roadmasterinc.com



1. Start by removing the plastic fasteners in the top of the front bumper fascia holding the radiator cover (Fig.C). These consist of 13 plastic fasteners for the Honda Pilot, or 15 for the Acura MDX. Set the cover aside.

2. Remove three fasteners from the front of each fender well, then two 10mm head bolts and two plastic fasteners under the bumper fascia on each side. Disconnect the fog lights, if the vehicle is so equipped, and pull forward to remove the fascia (Fig.D,E,F).



3. Disconnect the ambient air sensor from the bumper core, then remove three 12mm (head) bolts per side and set the bumper core aside (Fig.G). The bumper core will not be reinstalled. *Note:* retain the bumper core and attachment hardware so that it can be replaced in case the bracket is ever removed

4. Remove the headlights (four 10mm head bolts and two plastic fasteners per headlight – Fig.H,I,J).



5. Remove the large black air box on the driver's side (two 10mm head bolts – Fig.K). *Note:* on some late model cars, you may not be able to remove the air box. If this is the case, remove the bolts and move the air box off to the side (Fig.L) to allow sufficient working room.



MOUNTING BRACKET KIT INSTALLATION INSTRUCTIONS

KIT# 1544-1
03/26/08
KS

ROADMASTER, Inc. 6110 NE 127th Ave. Vancouver, WA 98682 1-800-669-9690 fax 360-735-9300 www.roadmasterinc.com



6. Remove three 10mm (head) mounting bolts holding the passenger side washer bottle. This will let you manipulate the bottle for frame access in the next steps (Fig.M).

7. Take the receiver brace and insert each side into the front of the frame opening, with the side mounting plate on top of the frame on each side (Fig.N).



8. On each side, bolt through the existing holes in the frame and the rear mounting holes in the brace with $\frac{1}{2}$ " x $4\frac{1}{2}$ " bolts, $\frac{1}{2}$ " plate washers, 2- $\frac{3}{8}$ " pipe spacers on the inside of the frame and $\frac{1}{2}$ " flat washers, lock washers and nuts on the motor side of the frame (Fig.O). Pushing the windshield washer bottle away from the frame on the passenger side will let you access the rear mounting hole.

9. Bolt through the front side plate top mounting hole on each side, using a 8mm x 25mm bolt, lock washer and flat washer (Fig.P).

10. You now have one top mounting hole left in each side of the receiver brace. Using the holes as drill templates, drill a $\frac{1}{2}$ " hole through the top of each frame (Fig.Q). Be careful of the transmission and power steering cooling lines on models with towing packages.



MOUNTING BRACKET KIT INSTALLATION INSTRUCTIONS

KIT# 1544-1
03/26/08
KS

ROADMASTER, Inc. 6110 NE 127th Ave. Vancouver, WA 98682 1-800-669-9690 fax 360-735-9300 www.roadmasterinc.com



11. Bolt through each top hole with a $\frac{1}{2}$ " x $1\frac{1}{2}$ " bolt, plate washer, lock washer and nut. Use the plate washer on the inside of the frame (Fig.R).

12. Now mark a center on the side of each frame rail, $\frac{5}{8}$ " from the end and $1\frac{3}{4}$ " down from the rail lip (Fig.S). Drill through the outside of the rails into the brace mounting holes with a $\frac{17}{32}$ " drill bit (Fig.T).

13. Bolt through in the same way as step 8 with the exception of using a $\frac{1}{2}$ " flat washer on the outside of the frame and a beveled $2\text{-}3/8$ " spacer in the frame. Be careful of the tubing on the inside of the frame on the passenger side (Fig.T).

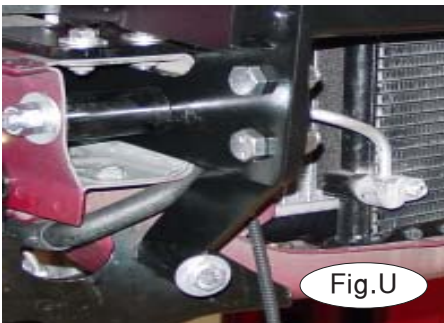

14. Now bolt the lower braces to the receiver brace with two $\frac{1}{2}$ " x $1\frac{1}{2}$ " lock washers and nuts per side. Bolt through the bottoms of the lower braces into existing nuts in the frame with 10mm x 1.25" x 80mm bolts, lock washers and flat washers (Fig.U).

15. Align the receiver brace and torque all mounting bolts to the torque specifications at the bottom of these instructions.

16. Using the included zip ties, attach the ambient air sensor removed in step 3 to the receiver brace as shown (Fig.V).

17. Replace the washer bottle mounting bolts removed in step 6.

18. Remount the driver's side air box removed in step 5.

19. Remount the bumper fascia and mark the grille ribs where the receiver pins will be located, then remove and trim (Honda Pilot only – Fig.W). *Note:* for the Acura MDX only, the bumper fascia will need to be trimmed as indicated in Fig.X.



MOUNTING BRACKET KIT INSTALLATION INSTRUCTIONS

KIT# 1544-1

03/26/08
KS

ROADMASTER, Inc. 6110 NE 127th Ave. Vancouver, WA 98682 1-800-669-9690 fax 360-735-9300 www.roadmasterinc.com

- 20. Install the headlights and radiator top cover, reversing steps 1 and 4.
- 21. Reinstall the bumper fascia, without the bumper core and shock absorption foam (the receiver brace assembly will replace these components), by reversing steps 1 and 2.
- 22. Insert the front braces into the receiver tubes (Fig.Y) and secure with 5/8" draw pins and spring pins. *Note:* the Acura MDX arms go up; the Honda Pilot arms go down.
- 23. Install the tow bar according to the manufacturer's instructions.
- 24. Attach one end of the 10" safety cables to the front holes on the receiver cross bar on each side of the receiver brace with the included cable connectors. Connect the other end to the tow vehicle's safety cables and the tow bar.



BOLT TORQUE REQUIREMENTS

Note: The torque values represented below are intended as general guidelines. Torque requirements for specific applications may vary. Roadmaster does not warrant this information to be accurate for all applications and disclaims all liability for any claims or damages which may result from its use.

STANDARD BOLTS

Thread Size	Grade	Torque
5/16	5	13 ft./lb.
3/8	5	23 ft./lb.
7/16	5	37 ft./lb.
1/2	5	56 ft./lb.
5/8	5	150 ft./lb.

METRIC BOLTS

Thread Size	Grade	Plated/Unplated
8mm-1.0	8.8	20 ft./lb. 18 ft./lb.
8mm-1.25	8.8	19 ft./lb. 18 ft./lb.
10mm-1.25	8.8	38 ft./lb. 36 ft./lb.
10mm-1.5	8.8	37 ft./lb. 35 ft./lb.

METRIC BOLTS

Thread Size	Grade	Plated/Unplated
12mm-1.25	8.8	70 ft./lb. 65 ft./lb.
12mm-1.5	8.8	66 ft./lb. 61 ft./lb.
12mm-1.75	8.8	65 ft./lb. 60 ft./lb.
14mm-2.0	8.8	104 ft./lb. 97 ft./lb.

All illustrations and specifications contained herein are based on the latest information available at the time of publication approval. ROADMASTER, INC. reserves the right to make changes at any time without notice in material, specification and models or to discontinue models.