



BASEPLATE KIT INSTALLATION INSTRUCTIONS

KIT# 1556-3

04/27/17
KS

ROADMASTER, Inc. 6110 NE 127th Ave. Vancouver, WA 98682 360-896-0407 fax 360-735-9300 www.roadmasterinc.com

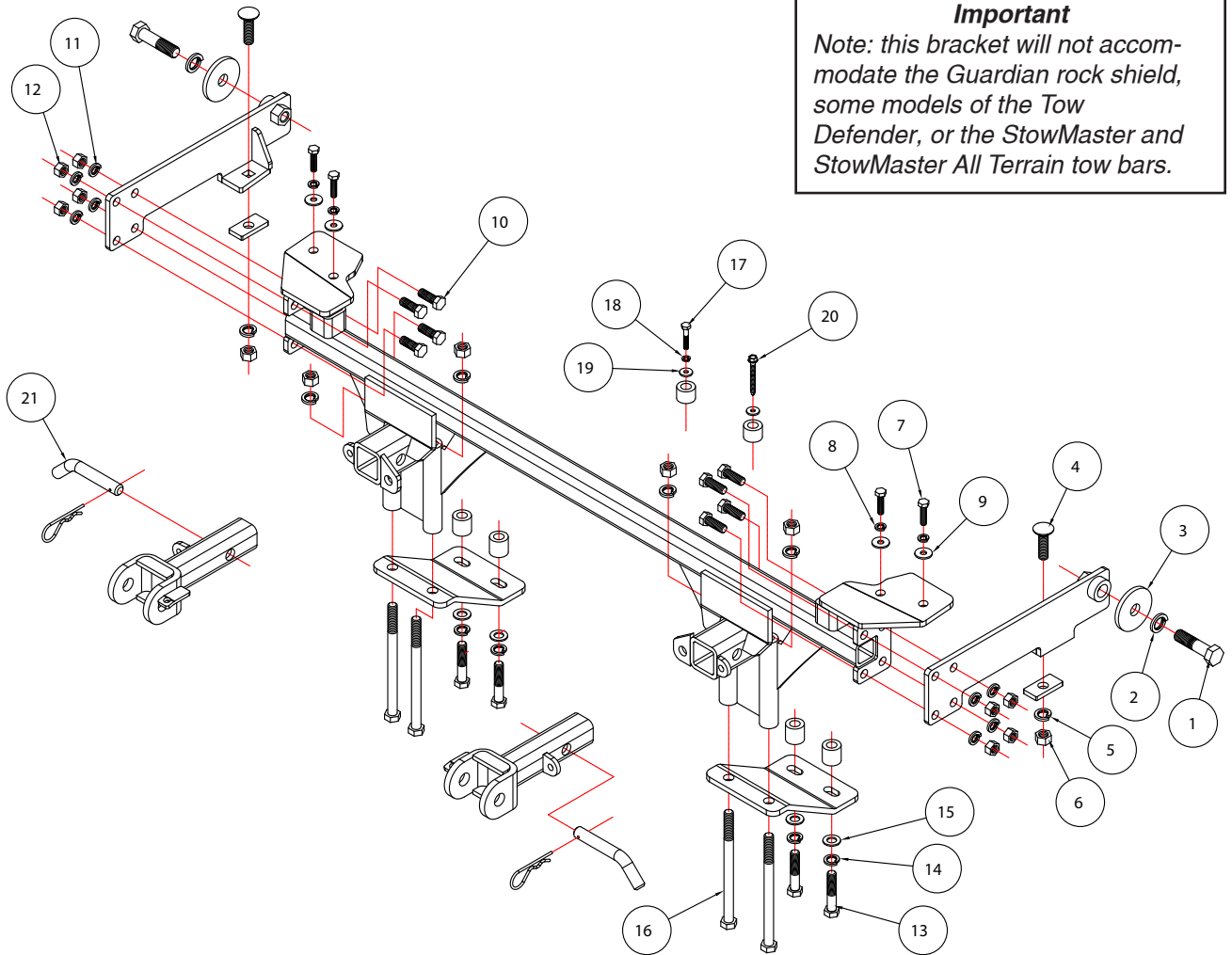

Important
Note: this bracket will not accommodate the Guardian rock shield, some models of the Tow Defender, or the StowMaster and StowMaster All Terrain tow bars.

ITEM	QTY	NAME	PART #
1	2	5/8" x 2 1/2" BOLTS	350150-20
2	2	5/8" LOCK WASHER	350313-00
3	2	5/8" PLATE WASHER	350352-00
4	2	1/2" x 1 3/4" CARRIAGE BOLT	350363-00
5	6	1/2" LOCK WASHER	350309-00
6	6	1/2" HEX NUT	350258-00
7	4	8mm x 1.25 x 30mm BOLT	356001-00
8	4	8mm LOCK WASHER	355705-00
9	4	8mm FENDER WASHER	355702-00
10	8	7/16" x 1 1/4" BOLT	350073-00
11	8	7/16" LOCK WASHER	350307-00
12	8	7/16" HEX NUT	350256-20
13	4	12mm x 1.25 x 60mm BOLT	357007-00
14	4	12mm LOCK WASHER	355725-00
15	4	12mm FLAT WASHER	355720-00
16	4	1/2" x 7" BOLT	350111-00
17	1	6mm x 1 x 35 mm BOLT	355896-00
18	1	6mm LOCK WASHER	355761-00
19	2	6mm FENDER WASHER	355755-00
20	1	1/4" x 2" SELF TAPPING SCREW	350317-00
21	2	5/8" DRAW PINS, SPRING PINS	357035-00



BASEPLATE KIT INSTALLATION INSTRUCTIONS

KIT# 1556-3

04/27/17
KS

ROADMASTER, Inc. 6110 NE 127th Ave. Vancouver, WA 98682 360-896-0407 fax 360-735-9300 www.roadmasterinc.com

Item	Qty.	Part #	Description
1.....	1.....	C-002098.....	DRIVER SIDE ARM BRACE WELDMENT
2.....	1.....	C-002099.....	PASSENGER SIDE ARM BRACE WELDMENT
3.....	1.....	C-001129.....	MAIN RECEIVER BRACE WELDMENT
4.....	1.....	C-001132.....	DRIVER SIDE SIDE BRACE WELDMENT
5.....	1.....	C-001133.....	PASSENGER SIDE SIDE BRACE WELDMENT
6.....	1.....	B-000766.....	DRIVER SIDE LOWER PLATE
7.....	1.....	B-000767.....	PASSENGER SIDE LOWER PLATE
8.....	2.....	A-000842.....	1" x 2" BACKING PLATE W/ ROUND HOLE
9.....	2.....	A-000558.....	1" O.D. x 3/4" x .219 WALL TUBE
10.....	4.....	A-001274.....	1" O.D. x 1" x .219 WALL TUBE

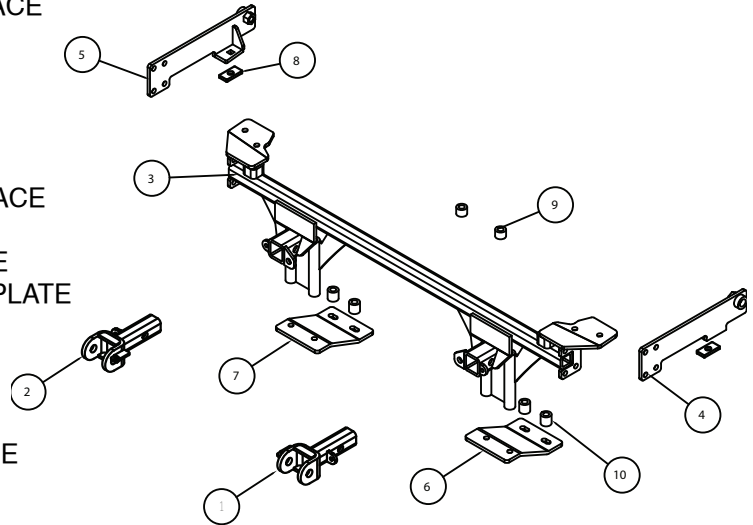

IMPORTANT: All baseplates **must** be assembled with all the bolts left loose for final adjustment and positioning (before tightening) unless otherwise instructed. All bolts **must** be torqued for proper strength. If more than one bolt is used per fastening point, the diagram may only show one. Use flat washers over all slotted holes and lock washers on all fasteners.

WARNING

Failure to heed these warnings or follow the installation instructions may result in a voided warranty, loss of towed vehicle, personal injury or death.

- Do not weld or modify this baseplate or its components. Welding or modification will void the warranty.
- Do not use this document as a basis to design/fabricate a baseplate, as it may not show all parts or structural components.
- We strongly recommend professional installation.
- If the towed vehicle has been in an accident, it must be properly repaired before attaching the baseplate. Do not install the baseplate if any structural frame damage is found.
- The installer must use all bolts and parts supplied. If running changes were made by the vehicle manufacturer after this kit was designed, some bolts or other fasteners may no longer be the correct size. It is the installer's responsibility to verify this kit is securely fastened to the vehicle.
- Use Loctite® Red on all bolts used to secure this baseplate. Torque all bolts to the specifications found at the end of these instructions. Do not over-torque the bolts or failure may occur.
- The installer must inspect the baseplate to ensure adequate clearance, particularly around hoses, air conditioner lines, radiators, etc. or non-warranty failure may result.
- Roadmaster manufactures many styles of baseplates. If your baseplate has removable arms, they must be removed before driving the vehicle, unless the arms can be pinned or padlocked in place. If not secured, the arms could vibrate out.
- Some motorhome chassis have such a tight turning radius that you can damage your motorhome, towed vehicle, tow bar or baseplate while turning sharply. Before getting on the road, test your turning radius in an empty parking lot. Turning too sharply could

result in non-warranty damage to your towing system, motorhome and/or towed vehicle.

- Do not back up with the towed vehicle attached or non-warranty damage will occur to your towing system or vehicles.
- The safety cables must connect the towing vehicle to the towed vehicle frame to frame, with the cables crossed, with enough slack for sharp turns. See cable instructions for proper routing. Failure to do so will result in non-warranty damage and/or the loss of the towed vehicle.
- This kit is designed for use with ROADMASTER tow bars and ROADMASTER adapters only. Using this kit with other brands, without an approved ROADMASTER adapter, may result in non-warranty damage or injury.
- Receiver extensions and out-of-level towing situations of 3 inches or more. This can cause the system to swing much higher and lower, causing excessive strain on the tow bar, baseplate and frame. That can cause the towing system to fail, causing property damage, personal injury or even death. If you must use a receiver extension or drop hitch to tow, it will reduce your receiver's weight capacity by 1/3 to avoid damaging your system. Never use more than one extension and/or drop hitch, as this will void your warranty.
- Every 3,000 miles, the owner must inspect all mounting points for cracks or fatigue, and check the fasteners for proper torque, according to the bolt torque requirements chart on the last page of these instructions.
- The owner must follow the vehicle manufacturer's instructions to prepare the vehicle for towing. Failure to do so may cause severe damage to the vehicle.
- This baseplate is only warranted for the original installation. Installing a used baseplate on another vehicle is not recommended and will void the warranty.



BASEPLATE KIT INSTALLATION INSTRUCTIONS

KIT# 1556-3

04/27/17
KS

ROADMASTER, Inc. 6110 NE 127th Ave. Vancouver, WA 98682 360-896-0407 fax 360-735-9300 www.roadmasterinc.com

This is one of our MX series brackets, which allows the visible front portion of the brackets to be easily removed from the front of the vehicle (Fig.A and Fig.B). The bracket kit consists of a main brace, two side braces, two lower braces, two removable front receiver braces, and a hardware pack.

1. **Important:** please use all supplied bolts and parts and read all instructions carefully before beginning this installation. The majority of questions you may have can be answered within the text, and proper installation will ensure safe and secure travel.

Now, begin the installation by removing the six plastic fasteners located across the front of the radiator cover (Fig.C).

2. Then, on each side, remove two plastic fasteners on the splash shield, inside the fender well (Fig.D).

3. On each side, remove one 10mm bolt on the bottom of the fascia, on the outside corner (Fig.E).

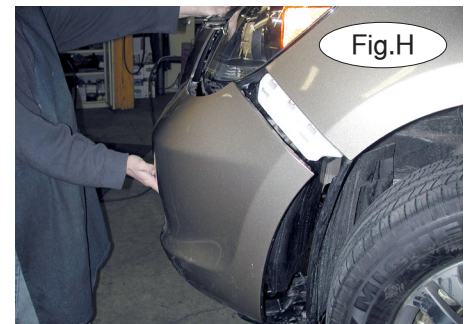
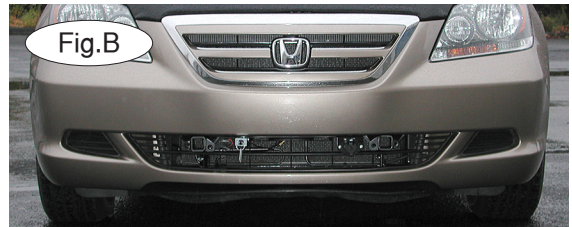

4. Remove 17 plastic fasteners connecting the splash shield and subframe to the fascia (Fig.F), then pull the splash shield out and away to remove it.

Note: the plastic fasteners you removed in the previous steps are all different sizes. They must be reinstalled in the same location.

5. On each side, pull the fender liner out and away. Then, remove one Phillips head screw at the corner of the fascia and the fender well (Fig.G).

6. Pull out and forward on each side of the fascia to detach it (Fig.H).

Note: disconnect the fog lights, if the vehicle is so equipped, before removing the fascia.

Note: if the vehicle is equipped with close proximity sensors, disconnect them as well. They are located on the front of the vehicle.

7. On the driver's side, remove the pop rivet at the top of the air box (Fig.I). Use a 90 degree drill or a die grinder to remove the head. (A standard drill can also be used, if the driver's side tire is removed.) This pop rivet will not be replaced.

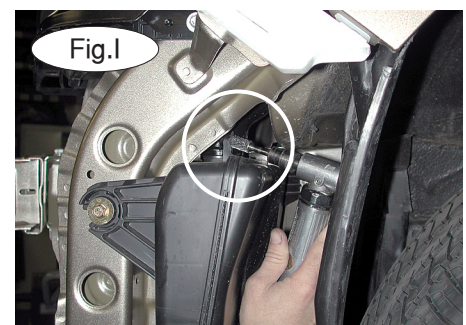



BASEPLATE KIT INSTALLATION INSTRUCTIONS

KIT# 1556-3

04/27/17
KS

ROADMASTER, Inc. 6110 NE 127th Ave. Vancouver, WA 98682 360-896-0407 fax 360-735-9300 www.roadmasterinc.com

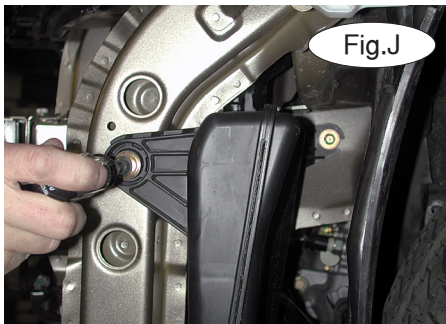

Fig.J



Fig.K



Fig.L

8. Next, remove the two 10mm head bolts holding the air box in place (Fig.J), and pull down and away to remove the air box (Fig.K).

9. On the passenger side, unplug the two water lines to the water bottle, as well as the electrical plug. Mark the water lines with colored markers (Fig.L) to identify them for later reassembly.



Fig.M

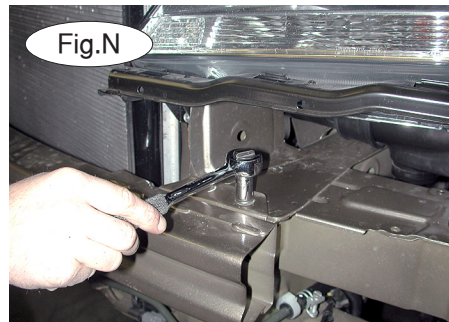

Fig.N

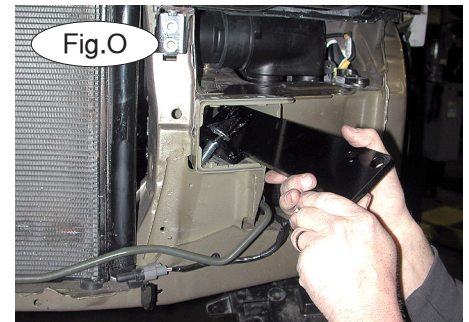

Fig.O

10. Detach the water bottle by removing the three 10mm (head) bolts. There are two below and one in the engine compartment (Fig.M).

11. Remove the three 12mm (head) bolts on each side of the bumper core (two on top, one underneath – Fig.N), then remove the bumper core. The bumper core will not be reinstalled.

12. Insert one of the supplied $\frac{1}{2}$ " x $1\frac{3}{4}$ " carriage bolts through one of the side braces, then position it inside the frame rail (Fig.O and Fig.P) so that the carriage bolt fits into the existing hole in the inner frame rail.

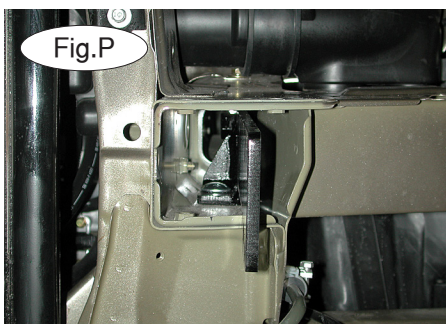

Fig.P

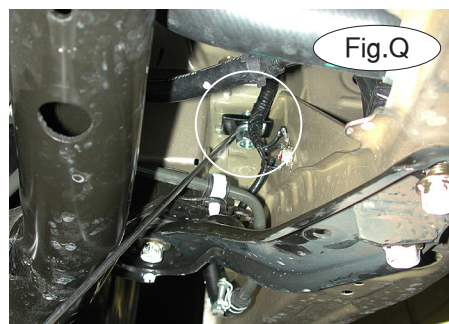

Fig.Q

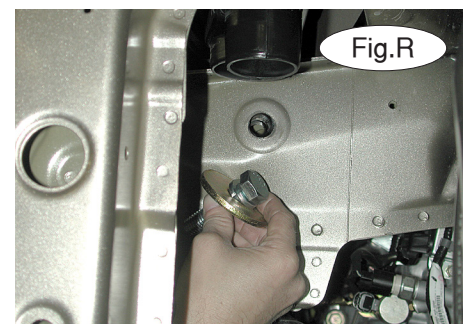

Fig.R

13. From the underside of the vehicle, thread one of the supplied $\frac{1}{2}$ " lock washers, $\frac{1}{2}$ " nut, and one of the $\frac{1}{4}$ " backing plates onto the carriage bolt. (Fig.Q). Finger-tighten only at this time. Figure R shows the bolt, lock washer and backing plate in place.

14. To secure the side brace, bolt through the existing hole in the side of the frame rail with one of the supplied $\frac{5}{8}$ " x $2\frac{1}{2}$ " bolts, plate washers and lock washers. Finger-tighten only at this time.

15. Repeat steps 12 through 14 to install the other side brace.



BASEPLATE KIT INSTALLATION INSTRUCTIONS

KIT# 1556-3

04/27/17
KS

ROADMASTER, Inc. 6110 NE 127th Ave. Vancouver, WA 98682 360-896-0407 fax 360-735-9300 www.roadmasterinc.com

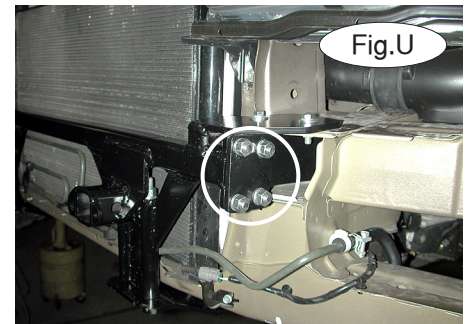
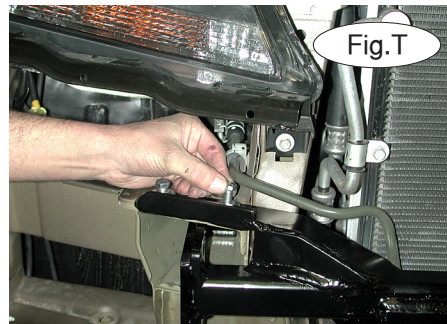
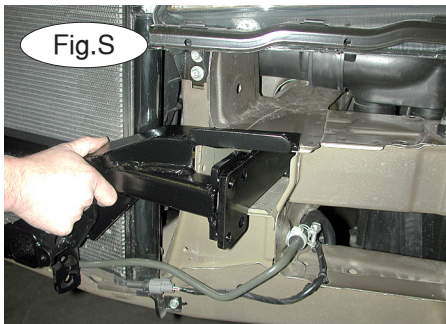

16. Set the main brace over the top of the frame rail (Fig.S).
17. Bolt the main brace to the frame rail, using the supplied 8mm x 1.25 x 30mm bolts, lock washers and fender washers (two on each side, Fig. T) to replace the four bumper core mounting bolts you removed from the top of the frame in step 11. Finger-tighten only at this time.
18. Bolt the main brace to the side braces – There are four mounting holes on each side. Use the supplied 7/16" x 1 1/4" bolts, lock washers and nuts for each mounting hole on each side. Finger-tighten only at this time.

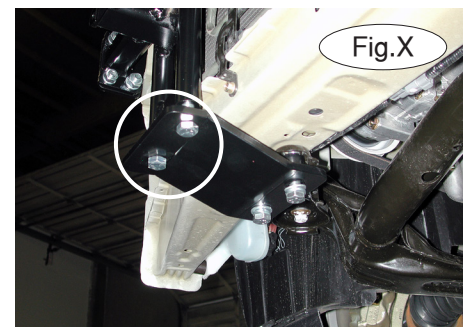
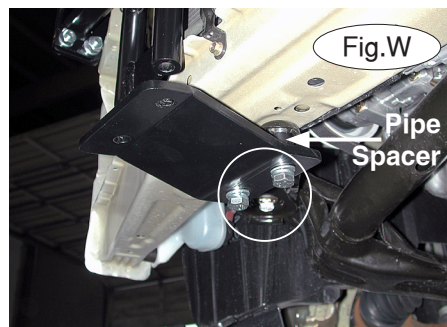

19. Remove the four (two on each side) 17mm head bolts from the bottom of the lower radiator support (Fig.V).
20. Attach the lower braces to the bottom of the radiator support – On each side, position one of the lower braces so that the holes in the brace align with the holes for the 17mm head bolts you removed in the previous step. Add one of the supplied 1" x 1" pipe spacers between the frame and the lower brace, over each hole (Fig.W). Then, thread two of the supplied 12mm x 1.25" x 60mm bolts, lock washers and flat washers through the lower brace, the pipe spacer and into the radiator support (Fig.W). Finger-tighten only at this time.
21. Attach the lower braces to the main brace, using two 1/2" x 7" bolts, lock washers and nuts on each side (Fig.X).
22. Torque all bolts to the specifications at the bottom of these instructions.



BASEPLATE KIT INSTALLATION INSTRUCTIONS

KIT# 1556-3

04/27/17
KS

ROADMASTER, Inc. 6110 NE 127th Ave. Vancouver, WA 98682 360-896-0407 fax 360-735-9300 www.roadmasterinc.com

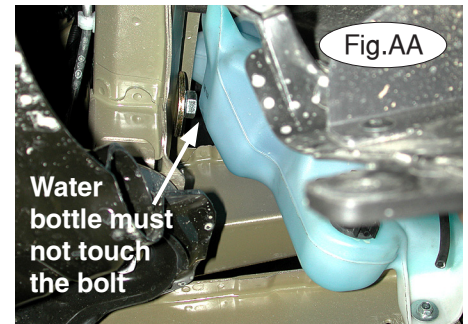
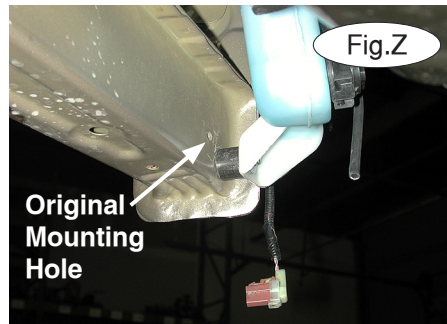
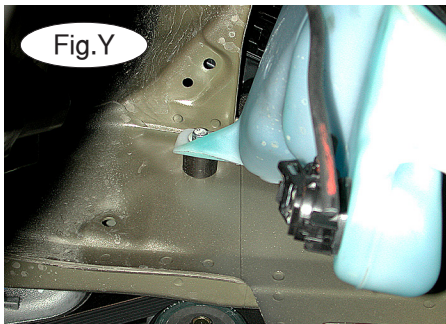

23. Reattach the water bottle: The top mounting point (engine compartment) is not used. For the upper hole inside the fender well, use the supplied 1" x 3/4" pipe spacer, 6mm x 1.0 x 35mm bolt, 6mm lock washer and fender washer (Fig.Y).
24. Reposition the remaining connection inside the fender well to a lower point, and more to the outside (Fig.Z). Use a 1/4" x 2" self-tapping screw, a 6mm fender washer, and a 1" x 3/4" pipe spacer. The water bottle must not touch the bolt – Figure AA shows clearance after reinstallation. Reattach the water lines and the electrical connection.

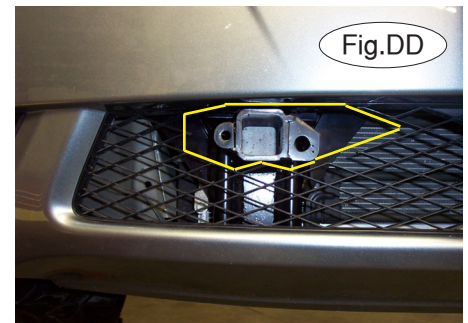
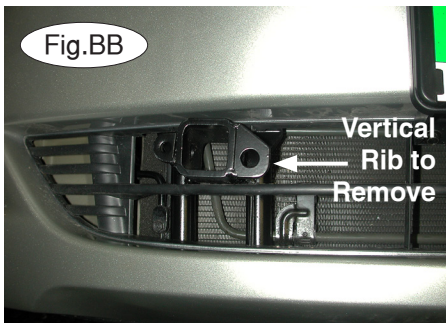

25. **On the '05 to '07 Honda Odyssey:** before reattaching the fascia, trim the grille and the splash panel to accommodate the front receiver braces and the bracket – On each side of the grille, remove one vertical rib (Fig.BB). Also on each side, remove the section of the splash panel outlined in green (Fig.CC). **On the '08 to '10 Honda Odyssey:** hold the fascia in place over the receivers and mark the grille opening for trimming. Figure DD shows the completed trimming.
26. Reinstall the air box and fascia by reversing steps 1 through 8.
27. Fit the front bracket arms into the front receiver braces, and secure them in place with the supplied 5/8" draw pins and spring pins.
30. Install the tow bar to the mounting bracket according to the manufacturer's instructions. Attach the safety cables to the main receiver brace.

BOLT TORQUE REQUIREMENTS

Note: The torque values represented below are intended as general guidelines. Torque requirements for specific applications may vary. Roadmaster does not warrant this information to be accurate for all applications and disclaims all liability for any claims or damages which may result from its use.

STANDARD BOLTS

Thread Size	Grade	Torque
5/16.....	5.....	13 ft./lb.
3/8.....	5.....	23 ft./lb.
7/16.....	5.....	37 ft./lb.
1/2.....	5.....	56 ft./lb.
5/8.....	5.....	150 ft./lb.

METRIC BOLTS

Thread Size	Grade	Plated / Unplated
8mm-1.0.....	8.8.....	20 ft./lb. 18 ft./lb.
8mm-1.25.....	8.8.....	19 ft./lb. 18 ft./lb.
10mm-1.25.....	8.8.....	38 ft./lb. 36 ft./lb.
10mm-1.5.....	8.8.....	37 ft./lb. 35 ft./lb.

METRIC BOLTS

Thread Size	Grade	Plated / Unplated
12mm-1.25.....	8.8.....	70 ft./lb. 65 ft./lb.
12mm-1.5.....	8.8.....	66 ft./lb. 61 ft./lb.
12mm-1.75.....	8.8.....	65 ft./lb. 60 ft./lb.
14mm-2.0.....	8.8.....	104 ft./lb. 97 ft./lb.

All illustrations and specifications contained herein are based on the latest information available at the time of publication approval. ROADMASTER, INC. reserves the right to make changes at any time without notice in material, specification and models or to discontinue models.