



BASEPLATE KIT INSTALLATION INSTRUCTIONS

KIT# 1619-3

10/25/04
RV

ROADMASTER, Inc. 6110 NE 127th Ave. Vancouver, WA 98682 360-896-0407 fax 360-735-9300 www.roadmasterinc.com

Important
Note: this bracket will not accommodate the Guardian rock shield, some models of the Tow Defender, Stowaway or the StowMaster and StowMaster All Terrain tow bars.

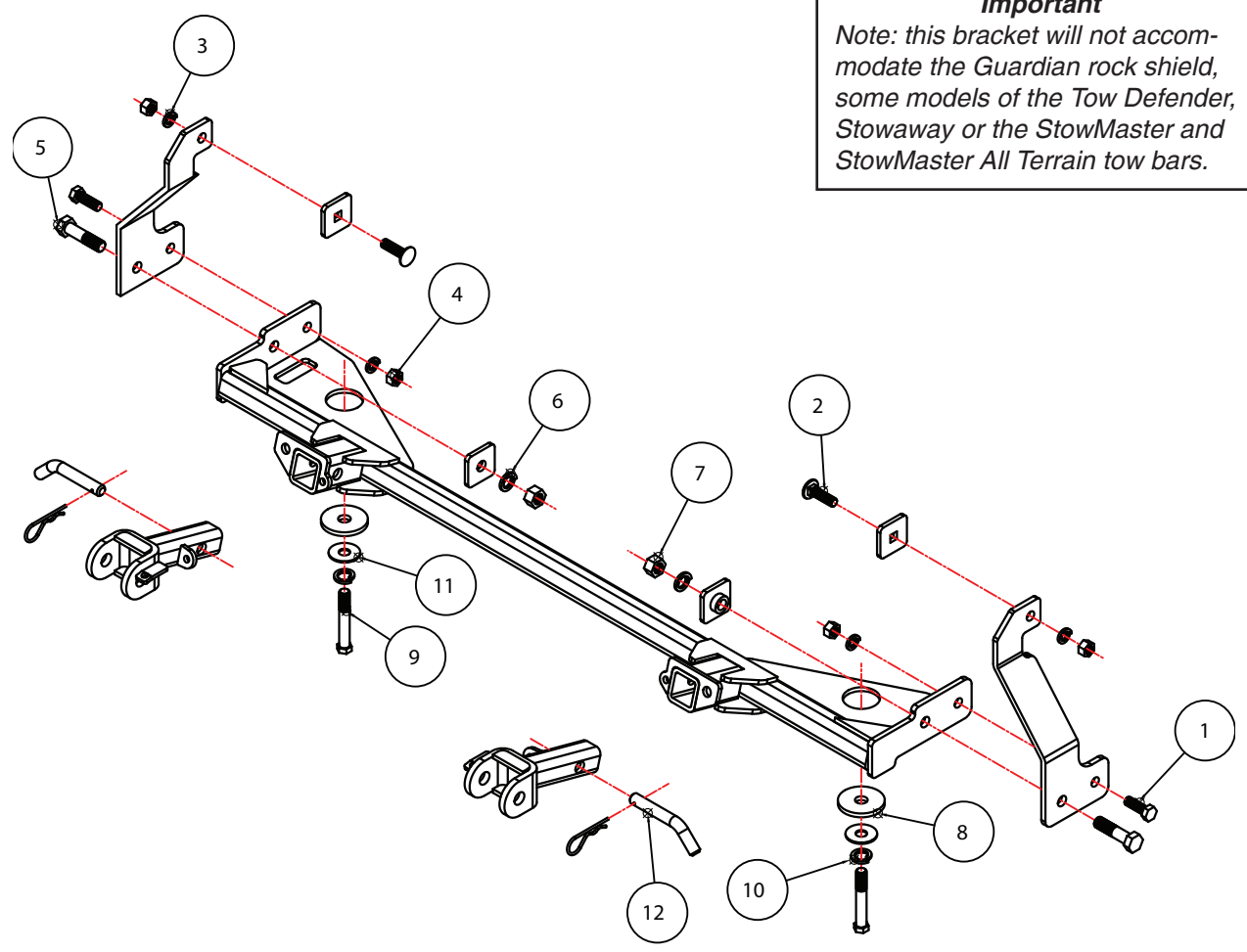

Item	Qty.	Length	Width	Description	Part#
1.....	2.....	1 1/2".....	1/2".....	1/2" x 1 1/2" BOLT	350095-00
2.....	2.....	1 3/4".....	1/2".....	1/2" x 1 3/4" CARRIDGE BOLT	350363-00
3.....	4.....	1/2".....	LOCK WASHER	350309-00
4.....	4.....	1/2".....	NUT.....	350258-00
5.....	2.....	2 1/2".....	5/8".....	5/8" x 2 1/2" BOLT	350150-20
6.....	2.....	5/8".....	LOCK WASHER	350313-00
7.....	2.....	5/8".....	NUT.....	350262-00
8.....	2.....	2 1/2".....	1/4".....	5/8" x 1/4" x 2 1/2" PLATE WASHER.....	350352-00
9.....	2.....	90mm.....	14mm.....	14mm x 1.5 x 90mm BOLT	357012-20
10.....	2.....	14mm.....	LOCK WASHER	355740-00
11.....	2.....	14mm.....	FENDER WASHER	355741-00
12.....	2.....	5/8".....	DRAW PINS, SPRING PINS	357035-00



BASEPLATE KIT INSTALLATION INSTRUCTIONS

KIT# 1619-3

10/25/04
RV

ROADMASTER, Inc. 6110 NE 127th Ave. Vancouver, WA 98682 360-896-0407 fax 360-735-9300 www.roadmasterinc.com

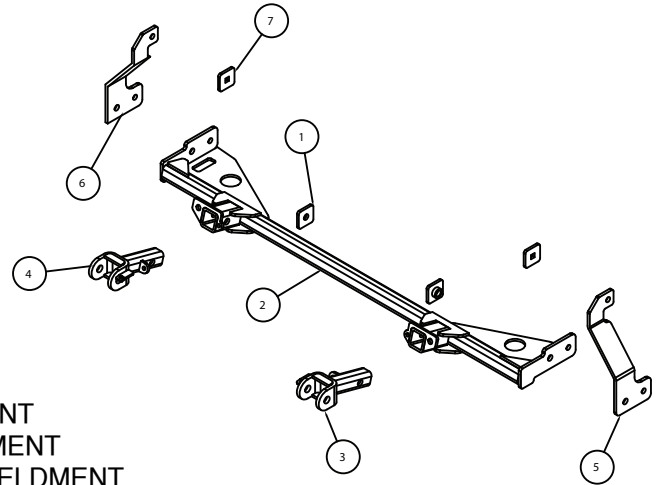

Item	Qty.	Part #	Description
1.....22	C-000105	BACKING PLATE WELDMENT
2.....11	C-001102	MAIN RECEIVER BRACE WELDMENT
3.....11	C-001105	DRIVER SIDE ARM BRACE WELDMENT
4.....11	C-001106	PASSENGER SIDE ARM BRACE WELDMENT
5.....11	B-000754	DRIVER SIDE MOUNTING BRACE
6.....11	B-000755	PASSENGER SIDE MOUNTING BRACE
7.....22	A-000189	1/4" x 2" x 2" BACKING PLATE

IMPORTANT: All baseplates **must** be assembled with all the bolts left loose for final adjustment and positioning (before tightening) unless otherwise instructed. All bolts **must** be torqued for proper strength. If more than one bolt is used per fastening point, the diagram may only show one. Use flat washers over all slotted holes and lock washers on all fasteners.

WARNING

Failure to heed these warnings or follow the installation instructions may result in a voided warranty, loss of towed vehicle, personal injury or death.

- Do not weld or modify this baseplate or its components. Welding or modification will void the warranty.
- Do not use this document as a basis to design/fabricate a baseplate, as it may not show all parts or structural components.
- We strongly recommend professional installation.
- If the towed vehicle has been in an accident, it must be properly repaired before attaching the baseplate. Do not install the baseplate if any structural frame damage is found.
- The installer must use all bolts and parts supplied. If running changes were made by the vehicle manufacturer after this kit was designed, some bolts or other fasteners may no longer be the correct size. It is the installer's responsibility to verify this kit is securely fastened to the vehicle.
- Use Loctite® Red on all bolts used to secure this baseplate. Torque all bolts to the specifications found at the end of these instructions. Do not over-torque the bolts or failure may occur.
- The installer must inspect the baseplate to ensure adequate clearance, particularly around hoses, air conditioner lines, radiators, etc. or non-warranty failure may result.
- Roadmaster manufactures many styles of baseplates. If your baseplate has removable arms, they must be removed before driving the vehicle, unless the arms can be pinned or padlocked in place. If not secured, the arms could vibrate out.
- Some motorhome chassis have such a tight turning radius that you can damage your motorhome, towed vehicle, tow bar or baseplate while turning sharply. Before getting on the road, test your turning radius in an empty parking lot. Turning too sharply could

result in non-warranty damage to your towing system, motorhome and/or towed vehicle.

- Do not back up with the towed vehicle attached or non-warranty damage will occur to your towing system or vehicles.
- The safety cables must connect the towing vehicle to the towed vehicle frame to frame, with the cables crossed, with enough slack for sharp turns. See cable instructions for proper routing. Failure to do so will result in non-warranty damage and/or the loss of the towed vehicle.
- This kit is designed for use with ROADMASTER tow bars and ROADMASTER adapters only. Using this kit with other brands, without an approved ROADMASTER adapter, may result in non-warranty damage or injury.
- Receiver extensions and out-of-level towing situations of 3 inches or more. This can cause the system to swing much higher and lower, causing excessive strain on the tow bar, baseplate and frame. That can cause the towing system to fail, causing property damage, personal injury or even death. If you must use a receiver extension or drop hitch to tow, it will reduce your receiver's weight capacity by 1/3 to avoid damaging your system. Never use more than one extension and/or drop hitch, as this will void your warranty.
- Every 3,000 miles, the owner must inspect all mounting points for cracks or fatigue, and check the fasteners for proper torque, according to the bolt torque requirements chart on the last page of these instructions.
- The owner must follow the vehicle manufacturer's instructions to prepare the vehicle for towing. Failure to do so may cause severe damage to the vehicle.
- This baseplate is only warranted for the original installation. Installing a used baseplate on another vehicle is not recommended and will void the warranty.



BASEPLATE KIT INSTALLATION INSTRUCTIONS

KIT# 1619-3

10/25/04
RV

ROADMASTER, Inc. 6110 NE 127th Ave. Vancouver, WA 98682 360-896-0407 fax 360-735-9300 www.roadmasterinc.com

This is one of our MX series brackets, which allows the visible front portion of the brackets to be easily removed from the front of the vehicle (Fig.A). The bracket kit consists of a main brace, two side braces, two removable front bracket arms, and a hardware pack.

Before starting the installation, lay out the kit components in order, starting with step 1. This will give you a visual idea of how the components work and will also confirm that everything is present and accounted for.

1. **Important:** please use all supplied bolts and parts and read all instructions carefully before beginning this installation. The majority of questions you may have can be answered within the text, and proper installation will ensure safe and secure travel. Now, begin the installation. Start by removing the headlights – Unscrew and remove the three 10mm bolts connecting each headlight to the frame (Fig.B), then disconnect the electrical plugs and remove the headlights.

2. Remove the eight plastic fasteners across the top of the fascia (Fig.C).

3. On each side of the fascia, remove the one Phillips head screw located at the top corner of the fender well (Fig.D). Then, remove the two Phillips head screws located at the bottom of each fender liner (Fig.E).

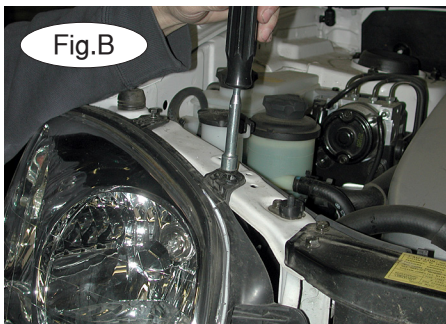

4. Remove the five 10mm bolts across the bottom of the fascia.

5. On each side, unplug the side marker lights and the fog lights (Fig.F). Then, remove the fascia.

6. Bolt the side braces to the tow hooks, using the supplied 5/8" x 2 1/2" bolts, 2" x 2" backing plates, 5/8" lock washers and 5/8" nuts (Fig.G). Make sure that both of the side braces are level (Fig. H).

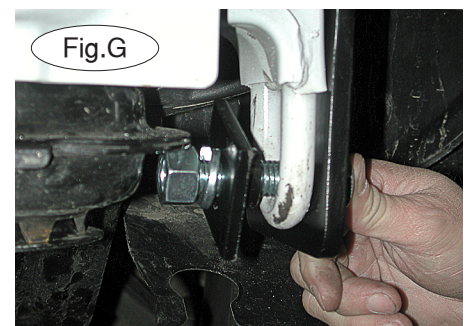

7. Using the upper hole in the side brace as a template, drill a 17/32" hole through the frame rail (Fig.I). Using the same method, drill an identical hole on the other side.

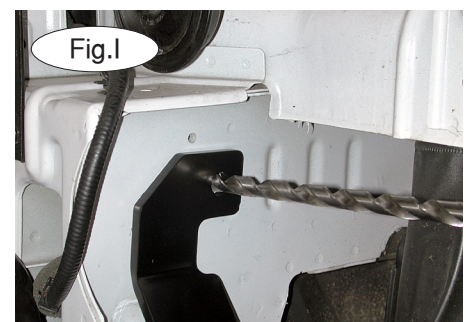
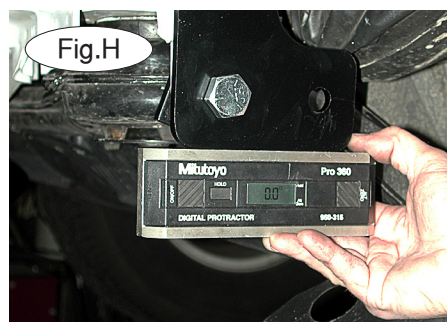



BASEPLATE KIT INSTALLATION INSTRUCTIONS

KIT# 1619-3

10/25/04
RV

ROADMASTER, Inc. 6110 NE 127th Ave. Vancouver, WA 98682 360-896-0407 fax 360-735-9300 www.roadmasterinc.com

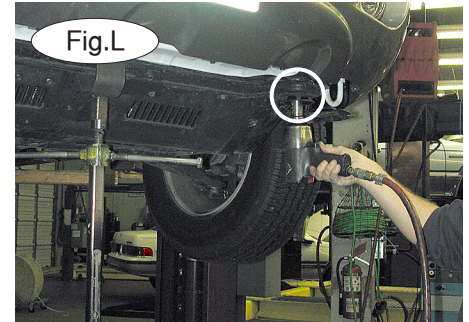
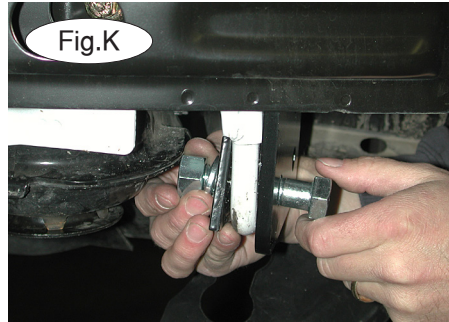
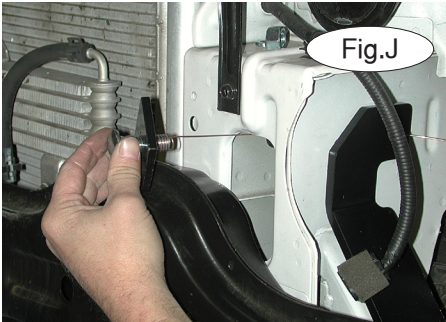

8. Fish wire the bolt through (Fig.J), and bolt the 2" x 2" upper backing plate in place with the supplied 1/2" x 1 3/4" carriage bolt, 1/2" lock washer and 1/2" nut. Repeat this process on the other side. Leave both of the bolts loose at this time.
9. Remove the 5/8" x 2 1/2" bolts, 2" x 2" backing plates, 5/8" lock washers and 5/8" nuts that you installed on both tow hooks in step 6 (Fig.K).
10. Reinstall the fascia, with the exception of the headlights and the fender liners – Screw in the one Phillips head screw at each corner of the fender well (Fig.D), then the eight plastic fasteners across the top of the fascia (Fig.C), then the five 10mm bolts across the bottom of the fascia.
11. Support the sub frame (Fig.L), and remove the two 19mm head sub frame bolts (one on each side).

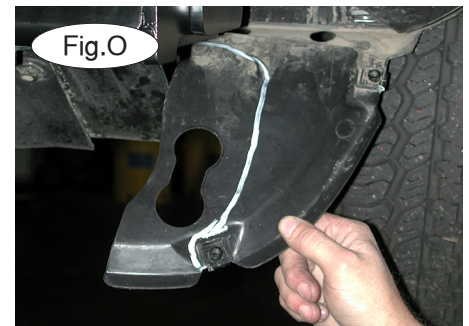
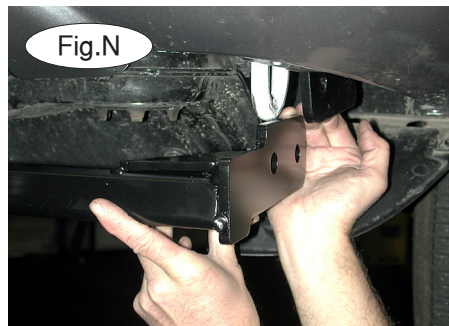

12. With the bushing cup between the bushing and the main brace (Fig.M), lift the main brace into place, with the main brace mounting plate between the tow hook and the side brace on each side (Fig.N). Now, bolt the main bracket brace to the sub frame on each side, using the supplied 14mm x 1.5" x 90mm sub frame bolts, 5/8" plate washers, 14mm flat washers and 14mm lock washers.
13. Reinstall the 5/8" x 2 1/2" bolts, 2" x 2" backing plates, 5/8" lock washers and 5/8" nuts onto the tow hooks on each side (Fig.K).
14. On each side, insert the 1/2" x 1 1/2" rear side brace bolts, 1/2" lock washers and 1/2" nuts through the lower rear hole on each side brace, and tighten the nuts.
15. Torque all the lower side brace bolts to the specifications at the end of these instructions.
16. Trim the fender liners so they can be reattached (Refer to the white marker in Fig.O.). Then, reattach each fender liner with the two Phillips head screws you removed in step 3 (Fig.E).



BASEPLATE KIT INSTALLATION INSTRUCTIONS

KIT# 1619-3

10/25/04
RV

ROADMASTER, Inc. 6110 NE 127th Ave. Vancouver, WA 98682 360-896-0407 fax 360-735-9300 www.roadmasterinc.com

- 17. From the top, tighten both of the upper side brace bolts (Fig.P) that you installed in step 8. Torque both to the specifications listed below.
- 18. Reinstall the headlights – On each side, screw in the three 10mm bolts that you removed in step 1 (Fig.B), then connect the electrical plugs. Plug in the fog light and the side marker light electrical connections on each side.
- 19. Ensure that all bolts are torqued to the specifications below.
- 20. Fit the front bracket arms into the front receiver braces, and secure them in place with the supplied 5/8" draw pins and spring pins (Fig.Q).
- 21. Install the tow bar to the mounting bracket according to the manufacturer's instructions. Attach the safety cables to the main receiver brace.

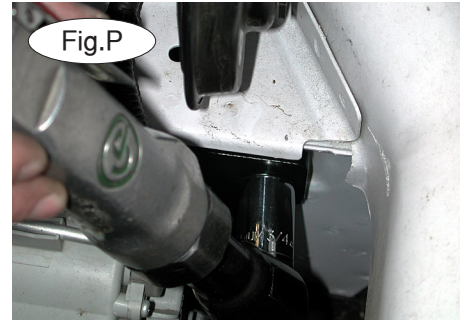

BOLT TORQUE REQUIREMENTS

STANDARD BOLTS

SIZE	GRADE	TORQUE
5/16	5	13 ft./lb.
3/8	5	23 ft./lb.
7/16	5	37 ft./lb.
1/2	5	56 ft./lb.
5/8	5	150 ft./lb.

METRIC BOLTS

SIZE	GRADE	PLATED / UNPLATED
M8-1.0	8.8	20 ft./lb. 18 ft./lb.
M8-1.25	8.8	19 ft./lb. 18 ft./lb.
M10-1.25	8.8	38 ft./lb. 36 ft./lb.
M 10-1.5	8.8	37 ft./lb. 35 ft./lb.

METRIC BOLTS

SIZE	GRADE	PLATED / UNPLATED
M12-1.25	8.8	70 ft./lb. 65 ft./lb.
M12-1.5	8.8	66 ft./lb. 61 ft./lb.
M12-1.75	8.8	65 ft./lb. 60 ft./lb.
M 14- 2.0	8.8	104 ft./lb. 97 ft./lb.

All illustrations and specifications contained herein are based on the latest information available at the time of publication approval. ROADMASTER, INC. reserves the right to make changes at any time without notice in material, specification and models or to discontinue models.