

BASEPLATE KIT INSTALLATION INSTRUCTIONS

ROADMASTER, Inc. 6110 NE 127th Ave. Vancouver, WA 98682 360-896-0407 fax 360-735-9300 www.roadmasterinc.com

PARTS LIST:

- 1- MAIN BRACE (A) - Passenger side
- 1- MAIN BRACE (B) - Driver's side
- 1- FRONT BRACE (C) - Passenger side
- 1- FRONT BRACE (D) - Driver's side
- 1- CROSS BRACE (E)
- 1- SIDE BRACE (F) - Passenger side
- 1- SIDE BRACE (G) - Driver's side

KIT NO. 162-3

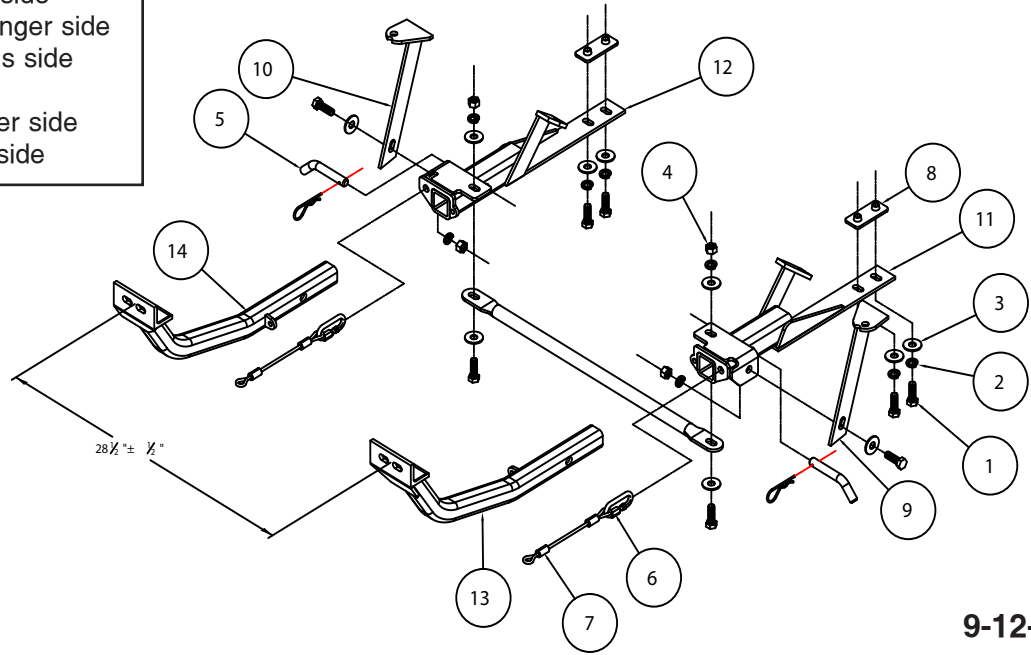

9-12-12

IMPORTANT: All baseplates **must** be assembled with all the bolts left loose for final adjustment and positioning (before tightening) unless otherwise instructed. All bolts **must** be torqued for proper strength. If more than one bolt is used per fastening point, the diagram may only show one. Use flat washers over all slotted holes and lock washers on all fasteners.

WARNING

Failure to heed these warnings or follow the installation instructions may result in a voided warranty, loss of towed vehicle, personal injury or death.

- Do not weld or modify this baseplate or its components. Welding or modification will void the warranty.
- Do not use this document as a basis to design/fabricate a baseplate, as it may not show all parts or structural components.
- We strongly recommend professional installation.
- If the towed vehicle has been in an accident, it must be properly repaired before attaching the baseplate. Do not install the baseplate if any structural frame damage is found.
- The installer must use all bolts and parts supplied. If running changes were made by the vehicle manufacturer after this kit was designed, some bolts or other fasteners may no longer be the correct size. It is the installer's responsibility to verify this kit is securely fastened to the vehicle.
- Use Loctite® Red on all bolts used to secure this baseplate. Torque all bolts to the specifications found at the end of these instructions. Do not over-torque the bolts or failure may occur.
- The installer must inspect the baseplate to ensure adequate clearance, particularly around hoses, air conditioner lines, radiators, etc. or non-warranty failure may result.
- Roadmaster manufactures many styles of baseplates. If your baseplate has removable arms, they must be removed before driving the vehicle, unless the arms can be pinned or padlocked in place. If not secured, the arms could vibrate out.
- Some motorhome chassis have such a tight turning radius that you can damage your motorhome, towed vehicle, tow bar or baseplate while turning sharply. Before getting on the road, test your turning radius in

an empty parking lot. Turning too sharply could result in non-warranty damage to your towing system, motorhome and/or towed vehicle.

- Do not back up with the towed vehicle attached or non-warranty damage will occur to your towing system or vehicles.
- The safety cables must connect the towing vehicle to the towed vehicle frame to frame, with the cables crossed, with enough slack for sharp turns. See cable instructions for proper routing. Failure to do so will result in non-warranty damage and/or the loss of the towed vehicle.
- This kit is designed for use with ROADMASTER tow bars and ROADMASTER adapters only. Using this kit with other brands, without an approved ROADMASTER adapter, may result in non-warranty damage or injury.
- Receiver extensions and out-of-level towing situations of 3 inches or more. This can cause the system to swing much higher and lower, causing excessive strain on the tow bar, baseplate and frame. That can cause the towing system to fail, causing property damage, personal injury or even death. If you must use a receiver extension or drop hitch to tow, it will reduce your receiver's weight capacity by 1/3 to avoid damaging your system. Never use more than one extension and/or drop hitch, as this will void your warranty.
- Every 3,000 miles, the owner must inspect all mounting points for cracks or fatigue, and check the fasteners for proper torque, according to the bolt torque requirements chart on the last page of these instructions.
- The owner must follow the vehicle manufacturer's instructions to prepare the vehicle for towing. Failure to do so may cause severe damage to the vehicle.
- This baseplate is only warranted for the original installation. Installing a used baseplate on another vehicle is not recommended and will void the warranty.

BASEPLATE KIT INSTALLATION INSTRUCTIONS

ROADMASTER, Inc. 6110 NE 127th Ave. Vancouver, WA 98682 360-896-0407 fax 360-735-9300 www.roadmasterinc.com

KIT NO. 162-3

- Important:** please use all supplied bolts and parts and read all instructions carefully before beginning this installation. The majority of questions you may have can be answered within the text, and proper installation will ensure safe and secure travel. Now, begin the installation. This bracket assembly utilizes the lower frame, subframe, and stabilizer bar mount as attachment points. Remove the lower plastic air dam located under the bumper. It will be necessary to trim and refit it later. Work on one side at a time, starting with the passenger side.
- Remove the top stabilizer bar mounting bolts from the stabilizer mounting bracket. Hold the lower main brace in position with the rear mounting tab over the top of the stabilizer mounting bracket. Reinstall the stabilizer bar mounting bolt through the braces rear mounting tab.
- Now, find the large subframe mount bolt near the front and above the brace. Remove this bolt and reinstall through the side brace mounting tab. Be sure to install as illustrated. Bolt the side brace to the main brace using the supplied 1/2" x 1 1/2" bolts, flat washers, lock washers and nut.
- Locate the existing holes in the sub frame that line up with the two holes in the rear lower brace extension. A 3/16" x 1 1/2" x 3 1/2" threaded backing plate will have to be fish wired through the hollow front of the sub frame and lined up with the 1/2" holes in the brace extension. Once the backing plate is inserted it can be held in place with a finger through a nearby access hole in the sub frame. Bolt through the lower brace extension and subframe using the supplied 1/2" x 1 1/2" bolts, flat washers, and lock washers.
- Repeat steps 2, 3 and 4 to install the driver side lower and side brace with the following exception. After fishwiring the nitted backing plate into position and bolting through the one available hole in the subframe, swing the backing plate to one side for clearance and drill a 1/2" hole through the subframe using the existing hole in the lower brace extension as a template.
- Bolt the center brace between the lower braces using two 1/2" x 1 1/2" bolts, flat washers, lock washers and nuts.
- Align the lower braces so they are parallel and level with each other, then tighten all bolts to the torque specifications below.
- Insert the front tubular braces into the lower receiver tubes making sure that they are mated to the correct side. If correct, the lock holes located on the receiver lip will match the front brace lock holes. Install the supplied 5/8" draw pins and 1/8" spring pins.
- Mount the tow bar according to the manufacturer's instructions. *Note:* the safety cables in the kit must be connected between the lower receiver and the vehicle's tow bar. A recess is provided on the front of each receiver near the top for this. These cables are to be used in addition to the standard tow cables or chains between the tow vehicle and towed vehicle.

ITEM	QTY	NAME	MATERIAL
1.....	8.....	1/2" x 1 1/2" BOLT.....	350095-00
2.....	8.....	1/2" LOCK WASHER.....	350309-00
3.....	10.....	1/2" FLAT WASHER.....	350308-00
4.....	4.....	1/2" HEX NUT.....	350258-00
5.....	2.....	DRAW PIN / SPRING PIN.....	357035-00
6.....	2.....	QUICK LINK.....	200008-00
7.....	2.....	19" SAFETY CABLE.....	650646-19
8.....	2.....	3/16" x 1 1/2" x 3 1/2" THREADED BACKING PLATE.....	A-003082
9.....	1.....	DRIVER SIDE BRACE.....	C-000380
10.....	1.....	PASSENGER SIDE BRACE.....	C-000381
11.....	1.....	DRIVER SIDE RECEIVER.....	C-000379
12.....	1.....	PASSENGER SIDE RECEIVER.....	C-000378
13.....	1.....	DRIVER SIDE ARM.....	C-000393
14.....	1.....	PASSENGER SIDE ARM.....	C-000392

9-12-12

BOLT TORQUE REQUIREMENTS

Note: The torque values represented below are intended as general guidelines. Torque requirements for specific applications may vary. Roadmaster does not warrant this information to be accurate for all applications and disclaims all liability for any claims or damages which may result from its use.

STANDARD BOLTS			METRIC BOLTS			METRIC BOLTS		
Thread Size	Grade	Torque	Thread Size	Grade	Plated / Unplated	Thread Size	Grade	Plated / Unplated
5/16.....	5.....	13 ft./lb.	8mm-1.0.....	8.8.....	20 ft./lb. 18 ft./lb.	12mm-1.25.....	8.8.....	70 ft./lb. 65 ft./lb.
3/8.....	5.....	23 ft./lb.	8mm-1.25.....	8.8.....	19 ft./lb. 18 ft./lb.	12mm-1.5.....	8.8.....	66 ft./lb. 61 ft./lb.
7/16.....	5.....	37 ft./lb.	10mm-1.25.....	8.8.....	38 ft./lb. 36 ft./lb.	12mm-1.75.....	8.8.....	65 ft./lb. 60 ft./lb.
1/2.....	5.....	56 ft./lb.	10mm-1.5.....	8.8.....	37 ft./lb. 35 ft./lb.	14mm-2.0.....	8.8.....	104 ft./lb. 97 ft./lb.
5/8.....	5.....	150 ft./lb.						