



BASEPLATE KIT INSTALLATION INSTRUCTIONS

KIT# 1620-1

10/17/12
KS

ROADMASTER, Inc. 6110 NE 127th Ave. Vancouver, WA 98682 360-896-0407 fax 360-735-9300 www.roadmasterinc.com

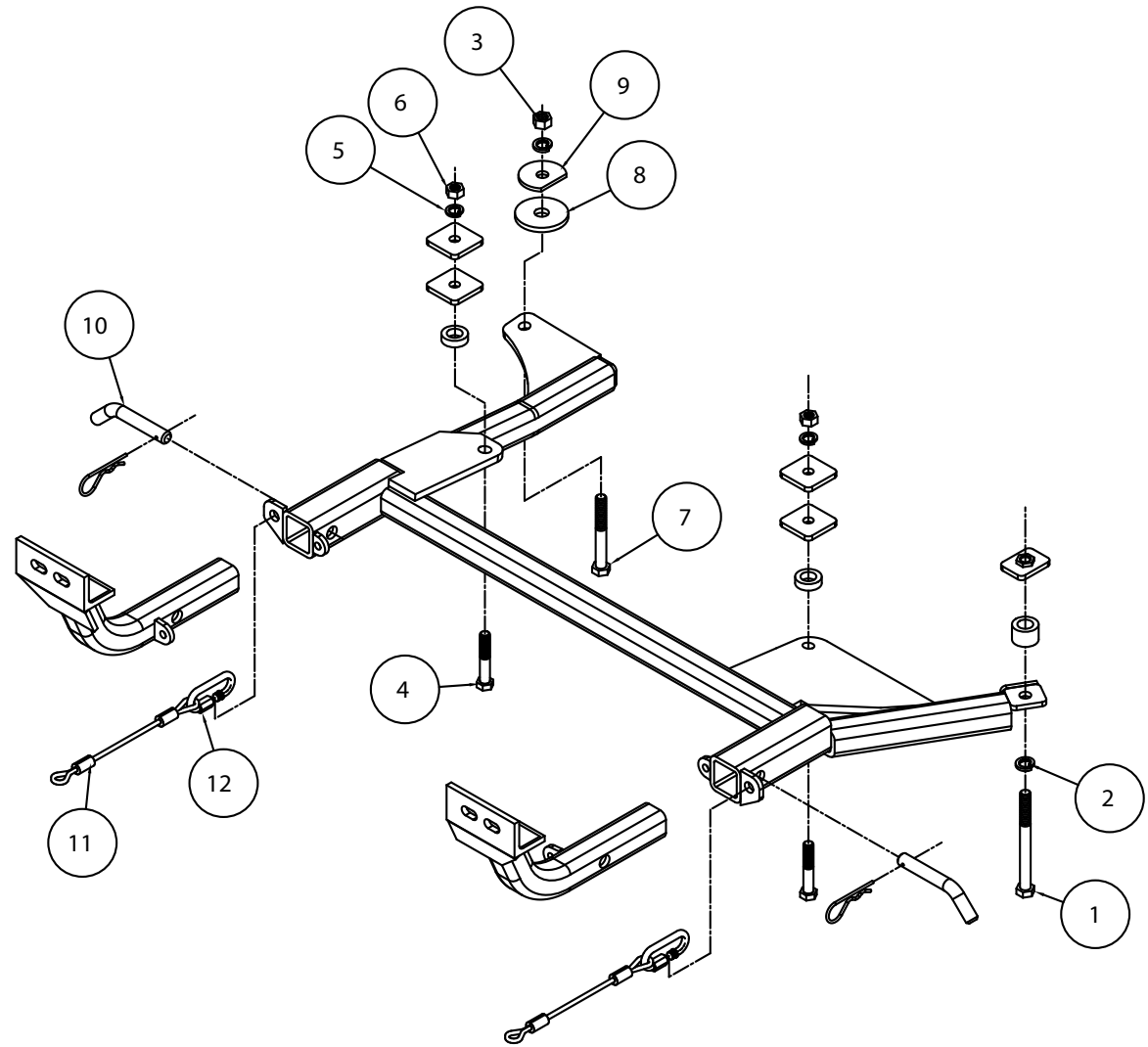

Item	Qty.	Length	Width	Description	Part #
1	1	5 1/2"	1/2"	BOLT	350108-00
2	2		1/2"	LOCK WASHER	350309-00
3	2		1/2"	NUT	350258-00
4	2	80MM	12MM	12MM X 1.5 X 80MM BOLT	357112-00
5	2		12MM	12MM LOCK WASHER	355725-00
6	2		12MM	12MM NUT	356241-00
7	1	4"	1/2"	BOLT	350259-00
8	1		1/2"	PLATE WASHER	350352-00
9	1	1 3/4"	2 1/4"	CLIPPED PLATE WASHER	A-002687
10	2			DRAW PIN/SPRING PIN	357035-00
11	2	8"		8" CABLE	500646-08
12	2			CABLE CONNECTORS	200008-00



BASEPLATE KIT INSTALLATION INSTRUCTIONS

KIT# 1620-1

10/17/12
KS

ROADMASTER, Inc. 6110 NE 127th Ave. Vancouver, WA 98682 360-896-0407 fax 360-735-9300 www.roadmasterinc.com

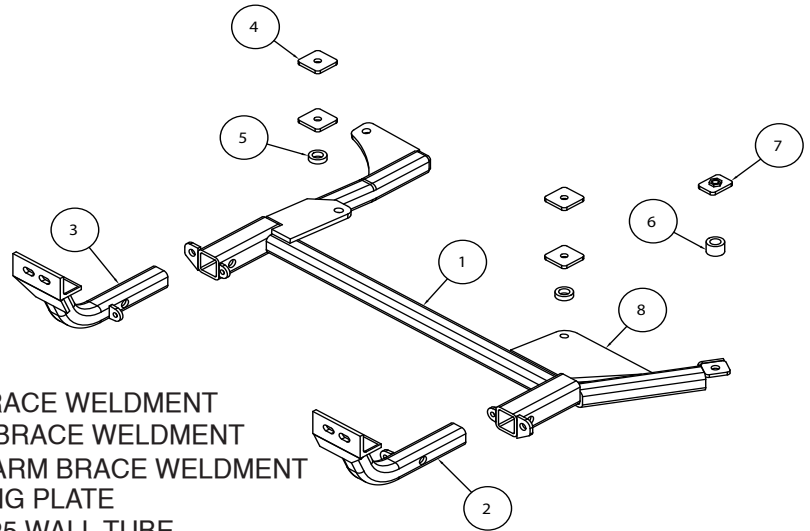

Item	Qty.	Part #	Description
1.....	1.....	C-001167.....	MAIN RECEIVER BRACE WELDMENT
2.....	1.....	C-001168.....	DRIVER SIDE ARM BRACE WELDMENT
3.....	1.....	C-001169.....	PASSENGER SIDE ARM BRACE WELDMENT
4.....	4.....	A-001066.....	1/4" x 2" x 2" BACKING PLATE
5.....	2.....	A-001869.....	1 1/4" O.D. x 3/8" x .25 WALL TUBE
6.....	1.....	A-000581.....	1 1/4" O.D. X 7/8" X .25 WALL TUBE
7.....	1.....	C-001010.....	1/4" x 1 1/2" x 2" THREADED BACKING PLATE
8.....	1.....	A-001873.....	DRIVER SIDE UPPER MOUNTING PLATE

IMPORTANT: All baseplates **must** be assembled with all the bolts left loose for final adjustment and positioning (before tightening) unless otherwise instructed. All bolts **must** be torqued for proper strength. If more than one bolt is used per fastening point, the diagram may only show one. Use flat washers over all slotted holes and lock washers on all fasteners.

WARNING

Failure to heed these warnings or follow the installation instructions may result in a voided warranty, loss of towed vehicle, personal injury or death.

- Do not weld or modify this baseplate or its components. Welding or modification will void the warranty.
- Do not use this document as a basis to design/fabricate a baseplate, as it may not show all parts or structural components.
- We strongly recommend professional installation.
- If the towed vehicle has been in an accident, it must be properly repaired before attaching the baseplate. Do not install the baseplate if any structural frame damage is found.
- The installer must use all bolts and parts supplied. If running changes were made by the vehicle manufacturer after this kit was designed, some bolts or other fasteners may no longer be the correct size. It is the installer's responsibility to verify this kit is securely fastened to the vehicle.
- Use Loctite® Red on all bolts used to secure this baseplate. Torque all bolts to the specifications found at the end of these instructions. Do not over-torque the bolts or failure may occur.
- The installer must inspect the baseplate to ensure adequate clearance, particularly around hoses, air conditioner lines, radiators, etc. or non-warranty failure may result.
- Roadmaster manufactures many styles of baseplates. If your baseplate has removable arms, they must be removed before driving the vehicle, unless the arms can be pinned or padlocked in place. If not secured, the arms could vibrate out.
- Some motorhome chassis have such a tight turning radius that you can damage your motorhome, towed vehicle, tow bar or baseplate while turning sharply. Before getting on the road, test your turning radius in an empty parking lot. Turning too sharply could

result in non-warranty damage to your towing system, motorhome and/or towed vehicle.

- Do not back up with the towed vehicle attached or non-warranty damage will occur to your towing system or vehicles.
- The safety cables must connect the towing vehicle to the towed vehicle frame to frame, with the cables crossed, with enough slack for sharp turns. See cable instructions for proper routing. Failure to do so will result in non-warranty damage and/or the loss of the towed vehicle.
- This kit is designed for use with ROADMASTER tow bars and ROADMASTER adapters only. Using this kit with other brands, without an approved ROADMASTER adapter, may result in non-warranty damage or injury.
- Receiver extensions and out-of-level towing situations of 3 inches or more. This can cause the system to swing much higher and lower, causing excessive strain on the tow bar, baseplate and frame. That can cause the towing system to fail, causing property damage, personal injury or even death. If you must use a receiver extension or drop hitch to tow, it will reduce your receiver's weight capacity by 1/3 to avoid damaging your system. Never use more than one extension and/or drop hitch, as this will void your warranty.
- Every 3,000 miles, the owner must inspect all mounting points for cracks or fatigue, and check the fasteners for proper torque, according to the bolt torque requirements chart on the last page of these instructions.
- The owner must follow the vehicle manufacturer's instructions to prepare the vehicle for towing. Failure to do so may cause severe damage to the vehicle.
- This baseplate is only warranted for the original installation. Installing a used baseplate on another vehicle is not recommended and will void the warranty.



BASEPLATE KIT INSTALLATION INSTRUCTIONS

KIT# 1620-1

10/17/12
KS

ROADMASTER, Inc. 6110 NE 127th Ave. Vancouver, WA 98682 360-896-0407 fax 360-735-9300 www.roadmasterinc.com

This bracket kit is one of our XL series, which allows the visible front portion of the brackets to be easily removed from the front of the vehicle. The kit consists of the main receiver brace, front braces and a hardware pack. The main receiver brace mounts behind and below the front bumper fascia to the front subframe (Fig.A). The front braces insert into the receiver brace on each side.

Before starting the installation, lay out the kit components in order, as they will be used. This will give you a visual idea of how the components work, and will also confirm that everything is present and accounted for.

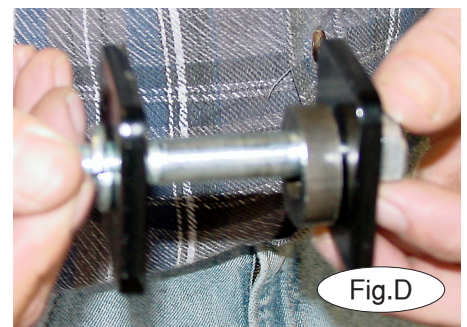
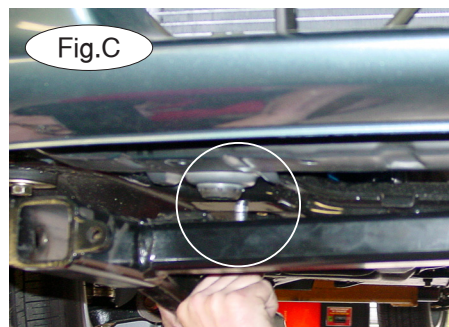
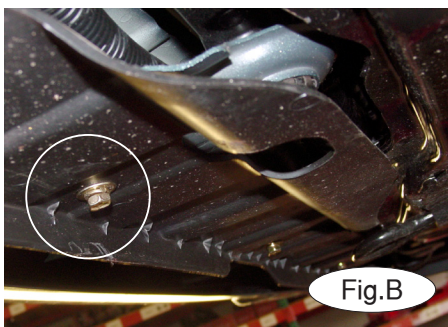

1. **Important:** please use all supplied bolts and parts and read all instructions carefully before beginning this installation. The majority of questions you may have can be answered within the text, and proper installation will ensure safe and secure travel. Now, begin the installation. Remove the lower center splash shield (five 10mm head bolts) to gain access to the bottom subframe (Fig.B).

2. Locate two holes in the large frame crossover member located under the engine. Hold the receiver brace to the bottom of the subframe and bolt through these holes, as illustrated in Figure C, with two 12mm x 1.5 x 80mm bolts, 1/4" x 2" x 2" backing plates, 3/8" spacers, lock washers and nuts (Fig.D).

3. Bolt through the driver's side outer mounting hole with a 1/2" x 5 1/2" bolt, 7/8" spacer, lock washer and a 1/4" x 1 1/2" x 2" threaded backing plate (Fig.E).

4. Now bolt through the rear passenger side mounting hole with a 1/2" x 4" bolt, 5/8" plate washer, cut 1/2" plate washer, lock washer and nut (Fig.F). Use the 5/8" plate washer as a spacer and the cut washer as a backing plate on the top of the frame.

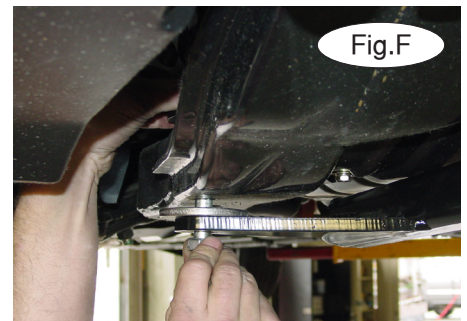
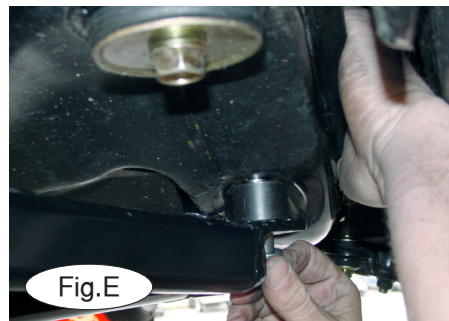

5. Torque all mounting bolts to the specifications at the bottom of these instructions.

6. Replace the lower center splash shield, trimming as needed.

7. Ensure that all bolts are torqued to the specifications at the bottom of these instructions.

8. Fit the front bracket arms into the front receiver braces, and secure them in place with the supplied 5/8" draw pins and spring pins.



BASEPLATE KIT INSTALLATION INSTRUCTIONS

KIT# 1620-1

10/17/12
KS

ROADMASTER, Inc. 6110 NE 127th Ave. Vancouver, WA 98682 360-896-0407 fax 360-735-9300 www.roadmasterinc.com

9. Attach the 8" safety cables with the cable connectors (Q-Links) to the front of the receiver braces (Fig.G).
10. Attach the ends of the safety cables to the tow vehicle's safety cables and tow bar.
11. Install the tow bar to the mounting bracket according to the manufacturer's instructions.



BOLT TORQUE REQUIREMENTS

Note: The torque values represented below are intended as general guidelines. Torque requirements for specific applications may vary. Roadmaster does not warrant this information to be accurate for all applications and disclaims all liability for any claims or damages which may result from its use.

STANDARD BOLTS

Thread Size	Grade	Torque
5/16.....	5.....	13 ft./lb.
3/8.....	5.....	23 ft./lb.
7/16.....	5.....	37 ft./lb.
1/2.....	5.....	56 ft./lb.
5/8.....	5.....	150 ft./lb.

METRIC BOLTS

Thread Size	Grade	Plated / Unplated
8mm-1.0	8.8	20 ft./lb. 18 ft./lb.
8mm-1.25	8.8	19 ft./lb. 18 ft./lb.
10mm-1.25	8.8	38 ft./lb. 36 ft./lb.
10mm-1.5	8.8	37 ft./lb. 35 ft./lb.

METRIC BOLTS

Thread Size	Grade	Plated / Unplated
12mm-1.25	8.8	70 ft./lb. 65 ft./lb.
12mm-1.5	8.8	66 ft./lb. 61 ft./lb.
12mm-1.75	8.8	65 ft./lb. 60 ft./lb.
14mm-2.0	8.8	104 ft./lb. 97 ft./lb.

All illustrations and specifications contained herein are based on the latest information available at the time of publication approval. ROADMASTER, INC. reserves the right to make changes at any time without notice in material, specification and models or to discontinue models.