



BASEPLATE KIT INSTALLATION INSTRUCTIONS

KIT# 2110-3

07/31/13
KS

ROADMASTER, Inc. 6110 NE 127th Ave. Vancouver, WA 98682 360-896-0407 fax 360-735-9300 www.roadmasterinc.com

Important
Note: this bracket will not accommodate the Guardian rock shield, some models of the Tow Defender, Stowaway or the StowMaster and StowMaster All Terrain tow bars.

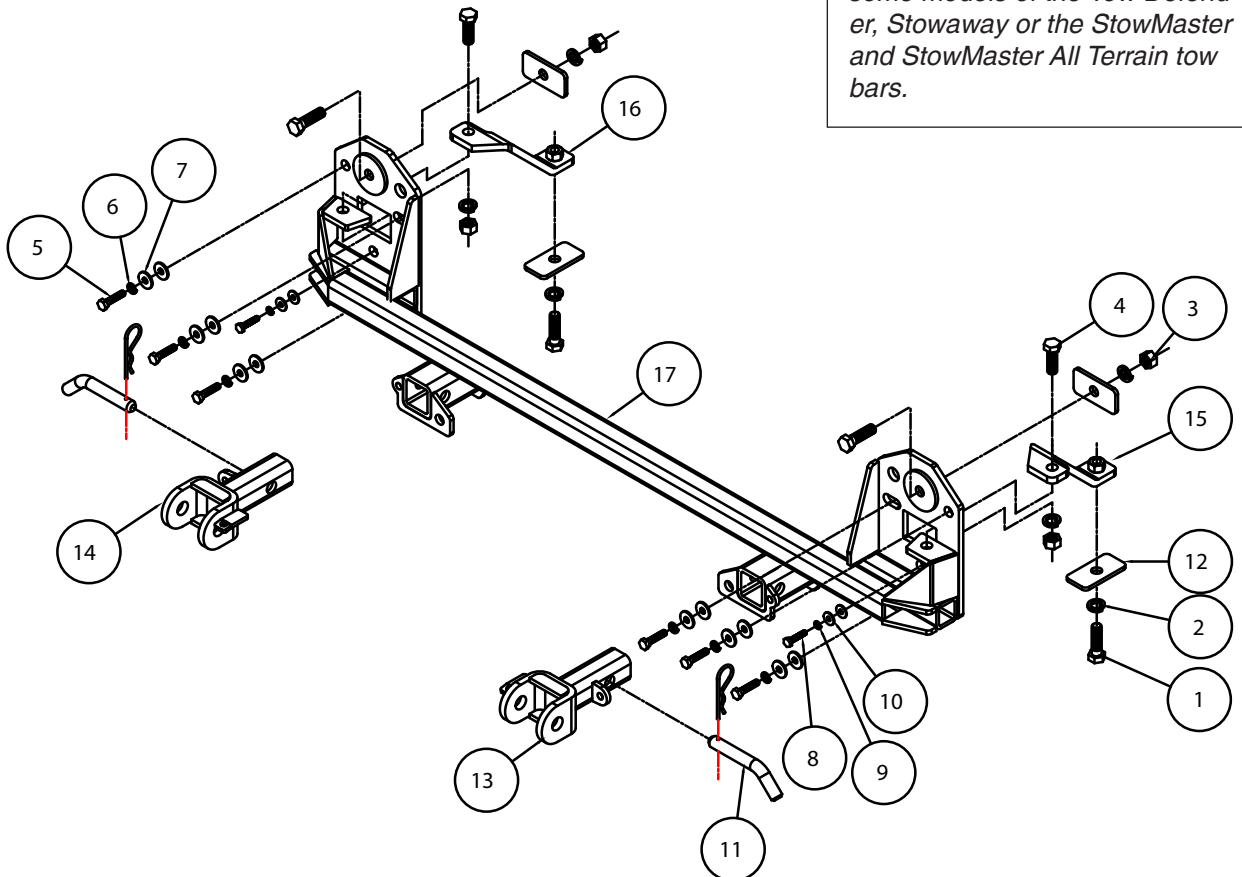

ITEM	QTY	NAME	MATERIAL
1	4	1/2" x 1 3/4" BOLT	350096-00
2	6	1/2" LOCK WASHER	350309-00
3	4	1/2" HEX NUT	350258-00
4	2	1/2" x 1 1/2" BOLT	350095-00
5	6	8mm x 1.25 x 35 mm BOLT	356002-00
6	6	8mm LOCK WASHER	355705-00
7	12	8mm FENDER WASHER	355702-00
8	2	6mm x 1.0 x 30 mtrm BOLT	355893-00
9	2	6mm LOCK WASHER	355761-00
10	4	6mm FENDER WASHER	355755-00
11	2	DRAW PIN W/ CLIP	357034-00
12	4	3/16"x 1 1/2" x 3" ROUND HOLE BACKING PLATE	A-000185
13	1	DRIVER SIDE MX ARM	C-001992
14	1	PASSENGER SIDE MX ARM	C-001993
15	1	DRIVER SIDE BRACE	C-001989
16	1	PASSENGER SIDE BRACE	C-001990
17	1	MAIN RECEIVER	C-001991



BASEPLATE KIT INSTALLATION INSTRUCTIONS

KIT# 2110-3

07/31/13
KS

ROADMASTER, Inc. 6110 NE 127th Ave. Vancouver, WA 98682 360-896-0407 fax 360-735-9300 www.roadmasterinc.com

This is one of our MX series brackets, which allows the visible front portion of the bracket to be easily removed from the front of the vehicle (Fig.A and Fig.B). The bracket consists of a main receiver brace, two removable front braces, two rear braces and a hardware pack.

The main receiver brace mounts to the frame rails and the bumper core mounting points. The removable front braces install in the main receiver brace.

Before starting the installation, lay out the kit components in order, as they will be used. This will give you a visual idea of how the components work, and will also confirm that everything is present and accounted for.



IMPORTANT: All baseplates **must** be assembled with all the bolts left loose for final adjustment and positioning (before tightening) unless otherwise instructed. All bolts **must** be torqued for proper strength. If more than one bolt is used per fastening point, the diagram may only show one. Use flat washers over all slotted holes and lock washers on all fasteners.

WARNING

Failure to heed these warnings or follow the installation instructions may result in a voided warranty, loss of towed vehicle, personal injury or death.

- Do not weld or modify this baseplate or its components. Welding or modification will void the warranty.
- Do not use this document as a basis to design/fabricate a baseplate, as it may not show all parts or structural components.
- We strongly recommend professional installation.
- If the towed vehicle has been in an accident, it must be properly repaired before attaching the baseplate. Do not install the baseplate if any structural frame damage is found.
- The installer must use all bolts and parts supplied. If running changes were made by the vehicle manufacturer after this kit was designed, some bolts or other fasteners may no longer be the correct size. It is the installer's responsibility to verify this kit is securely fastened to the vehicle.
- Use Loctite® Red on all bolts used to secure this baseplate. Torque all bolts to the specifications found at the end of these instructions. Do not over-torque the bolts or failure may occur.
- The installer must inspect the baseplate to ensure adequate clearance, particularly around hoses, air conditioner lines, radiators, etc. or non-warranty failure may result.
- Roadmaster manufactures many styles of baseplates. If your baseplate has removable arms, they must be removed before driving the vehicle, unless the arms can be pinned or padlocked in place. If not secured, the arms could vibrate out.
- Some motorhome chassis have such a tight turning radius that you can damage your motorhome, towed vehicle, tow bar or baseplate while turning sharply. Before getting on the road, test your turning radius in an empty parking lot. Turning too sharply could result in non-warranty damage to your towing system, motorhome and/or towed vehicle.
- Do not back up with the towed vehicle attached or non-warranty damage will occur to your towing system or vehicles.
- The safety cables must connect the towing vehicle to the towed vehicle frame to frame, with the cables crossed, with enough slack for sharp turns. See cable instructions for proper routing. Failure to do so will result in non-warranty damage and/or the loss of the towed vehicle.
- This kit is designed for use with ROADMASTER tow bars and ROADMASTER adapters only. Using this kit with other brands, without an approved ROADMASTER adapter, may result in non-warranty damage or injury.
- Receiver extensions and out-of-level towing situations of 3 inches or more. This can cause the system to swing much higher and lower, causing excessive strain on the tow bar, baseplate and frame. That can cause the towing system to fail, causing property damage, personal injury or even death. If you must use a receiver extension or drop hitch to tow, it will reduce your receiver's weight capacity by 1/3 to avoid damaging your system. Never use more than one extension and/or drop hitch, as this will void your warranty.
- Every 3,000 miles, the owner must inspect all mounting points for cracks or fatigue, and check the fasteners for proper torque, according to the bolt torque requirements chart on the last page of these instructions.
- The owner must follow the vehicle manufacturer's instructions to prepare the vehicle for towing. Failure to do so may cause severe damage to the vehicle.
- This baseplate is only warranted for the original installation. Installing a used baseplate on another vehicle is not recommended and will void the warranty.



BASEPLATE KIT INSTALLATION INSTRUCTIONS

KIT# 2110-3

07/31/13
KS

ROADMASTER, Inc. 6110 NE 127th Ave. Vancouver, WA 98682 360-896-0407 fax 360-735-9300 www.roadmasterinc.com



1. **Important:** please use all supplied bolts and parts and read all instructions carefully before beginning this installation. The majority of questions you may have can be answered within the text, and proper installation will ensure safe and secure travel. Now, begin the installation by removing two 10mm (head) bolts and four plastic fasteners attaching the top of the grille to the radiator support (Fig.C).

2. On each side, remove one Phillips screw attaching the corner of the fascia to the fender (Fig.D – driver's side).



3. Remove eight plastic fasteners attaching the bottom of the fascia to the radiator support and center splash shield. *Note:* these are located inside the fascia, along the bottom.

4. Pull out and forward on the corners of the fascia to remove (Fig.E).

5. Remove seven 12mm (head) bolts and two plastic fasteners attaching the center splash shield to the subframe and radiator support (Fig.F).

6. On each side, remove three 12mm (head) bolts and one 10mm (head) bolt attaching the bumper core to the end of the frame rail (Fig.G). *Note:* retain the bumper core and attachment hardware so that it can be replaced if the bracket is ever removed.

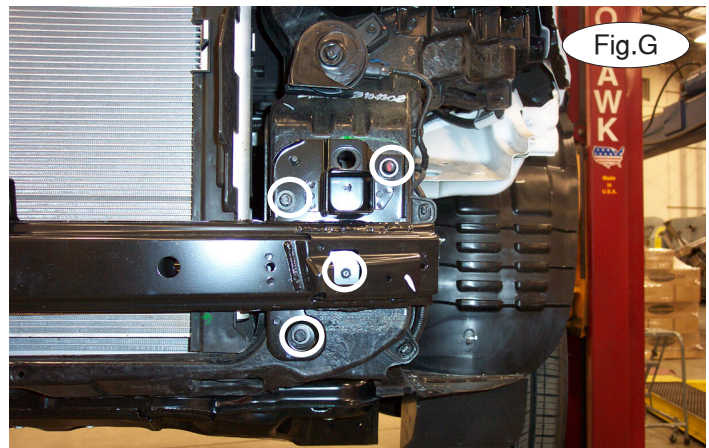



BASEPLATE KIT INSTALLATION INSTRUCTIONS

KIT# 2110-3

07/31/13
KS

ROADMASTER, Inc. 6110 NE 127th Ave. Vancouver, WA 98682 360-896-0407 fax 360-735-9300 www.roadmasterinc.com

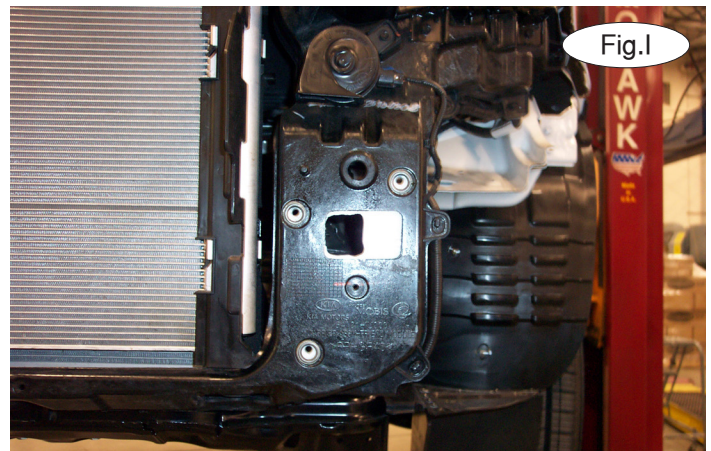
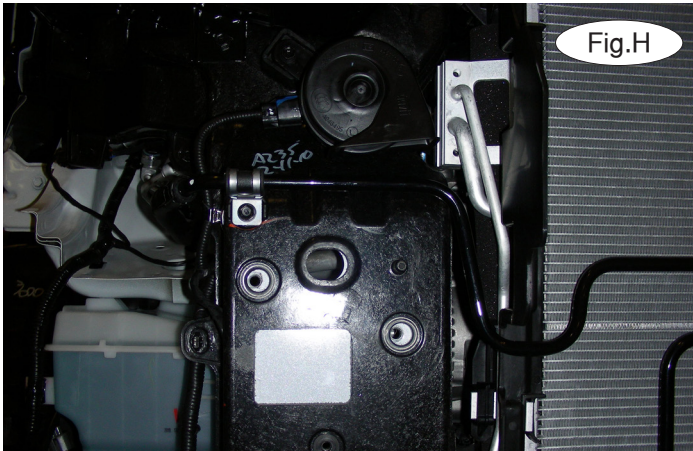

7. On each side, locate the metal square in the end of the frame rail (Fig.H). Use a 1" hole saw to drill a hole in this square, enlarging the square to 1 $\frac{3}{4}$ " x 1 $\frac{3}{4}$ " (Fig.I).

8. On each side, place the main receiver brace over the bumper core mounting point in the end of the frame rail. Using the three supplied 8mm x 1.25 x 35mm bolts and 8mm lock washers, and six 8mm fender washers (two per bolt), bolt through the three outside mounting points. Using the two supplied 6mm x 1.0 x 30mm bolts and 6mm lock washers, and four 6mm fender washers (two per bolt), bolt through the inside point on each side (Fig.J).

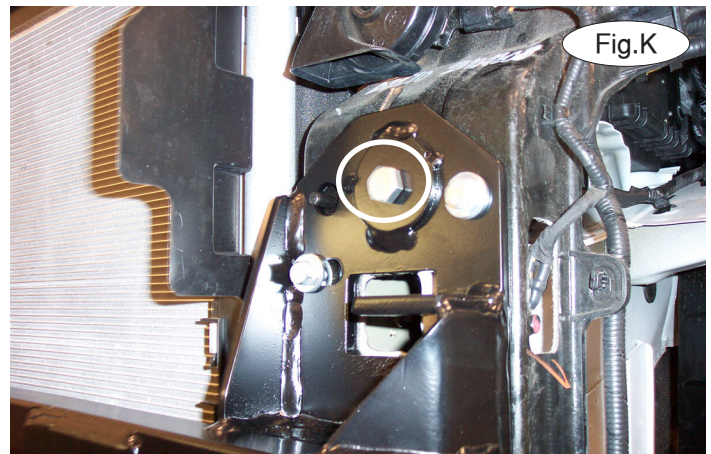
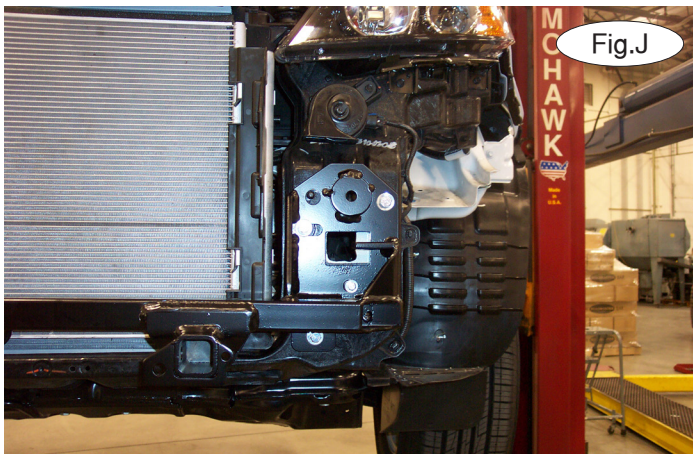

9. Tighten the bolts to the bolt torque requirements found at the end of these instructions.

10. On the passenger side, make certain the power steering cooler line is not contacting the bolt head. If it is, pry it up and out of the way.

11. On each side, place one of the supplied $\frac{1}{2}$ " x 1 $\frac{3}{4}$ " bolts through the upper mounting point of the main receiver brace (Fig.K). Place one of the $\frac{3}{16}$ " x 1 $\frac{1}{2}$ " x 3" backing plates over the back side of the bolt to the inside of the frame, and bolt it into place using a $\frac{1}{2}$ " lock washer and nut. Tighten the bolts to the bolt torque requirements found at the end of these instructions.



BASEPLATE KIT INSTALLATION INSTRUCTIONS

KIT# 2110-3

07/31/13
KS

ROADMASTER, Inc. 6110 NE 127th Ave. Vancouver, WA 98682 360-896-0407 fax 360-735-9300 www.roadmasterinc.com

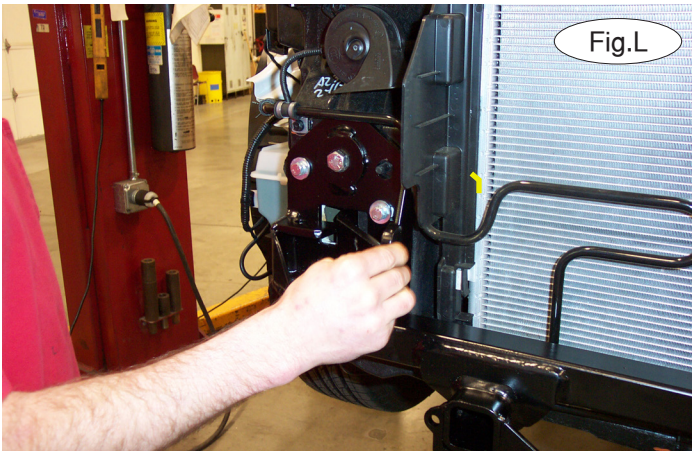

Fig.L

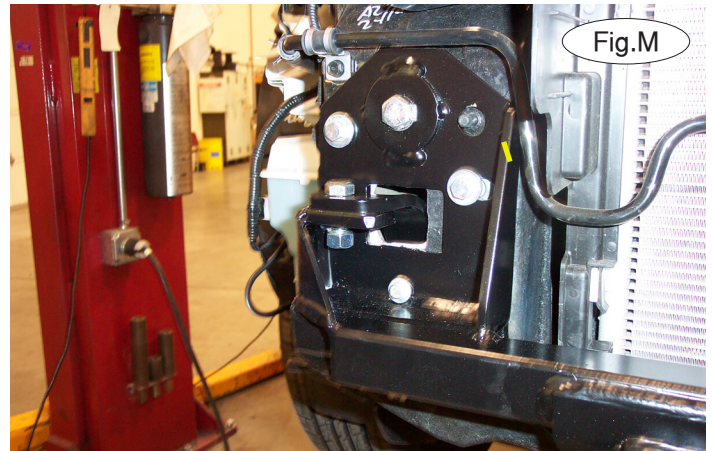

Fig.M

12. On each side, place the rear brace through the opening in the frame (Fig.L). Bolt the rear brace to the main receiver brace using one of the supplied $\frac{1}{2}$ " x $1\frac{1}{2}$ " bolts, $\frac{1}{2}$ " lock washers and nuts (Fig.M).

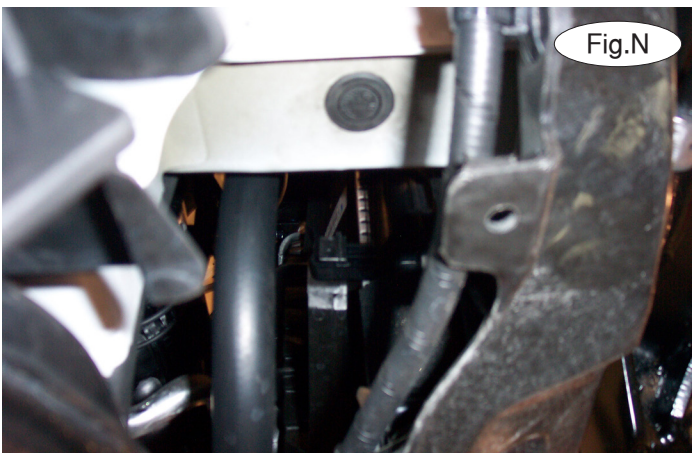

Fig.N

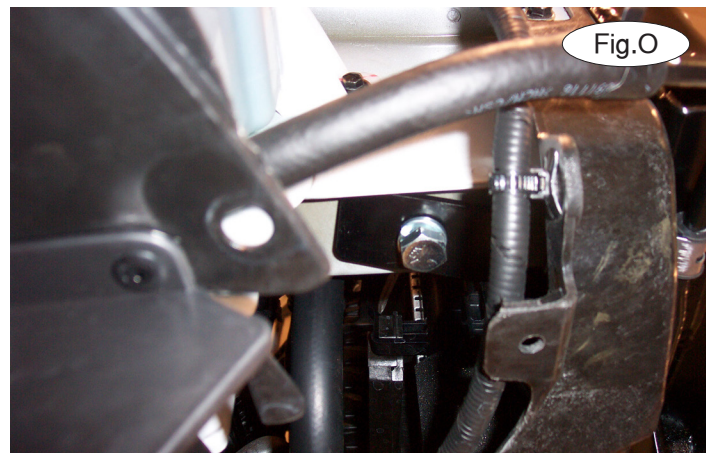

Fig.O

13. Remove the plugs in the bottom of the frame rail (Fig.N). Now, place a $\frac{3}{16}$ " x $1\frac{1}{2}$ " x 2" backing plate over one of the supplied $\frac{1}{2}$ " x $1\frac{3}{4}$ " bolts and bolt through the bottom of the frame rail and into the rear support brace (Fig.O).

14. Tighten the bolts to the bolt torque requirements found at the end of this document.

15. On the back of the fascia, remove the two plastic clips attaching the foam shock absorption pad to the fascia (Fig.P). It will not be replaced. *Note:* retain the foam shock absorption pad and attachment hardware so that it can be replaced if the bracket is ever removed.

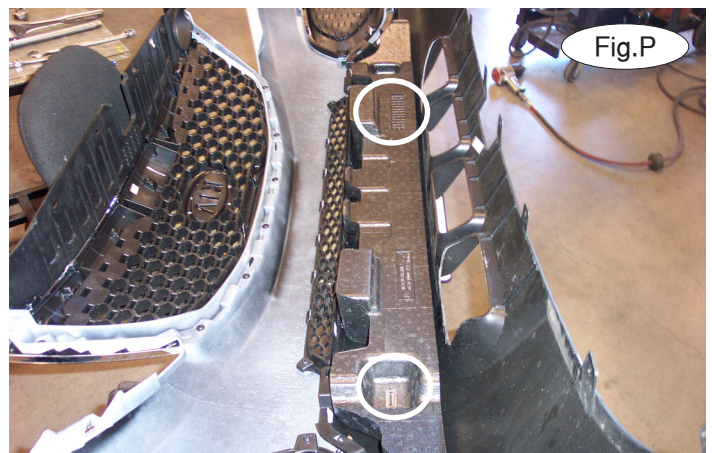

Fig.P



BASEPLATE KIT INSTALLATION INSTRUCTIONS

KIT# 2110-3

07/31/13
KS

ROADMASTER, Inc. 6110 NE 127th Ave. Vancouver, WA 98682 360-896-0407 fax 360-735-9300 www.roadmasterinc.com

- 16. Trim the grille opening to allow clearance for the main receiver brace. On each side, measure 2¼" from top of the outside opening and trim (Fig.Q).
- 17. Reassemble the fascia by reversing steps 1 through 5.
- 18. Fit the front bracket arms into the front receiver braces, and secure them in place with the supplied 5/8" draw pins and spring pins.
- 19. Install the tow bar to the mounting bracket according to the manufacturer's instructions. Connect the safety cables to the safety cable tabs illustrated on the first page of these instructions.

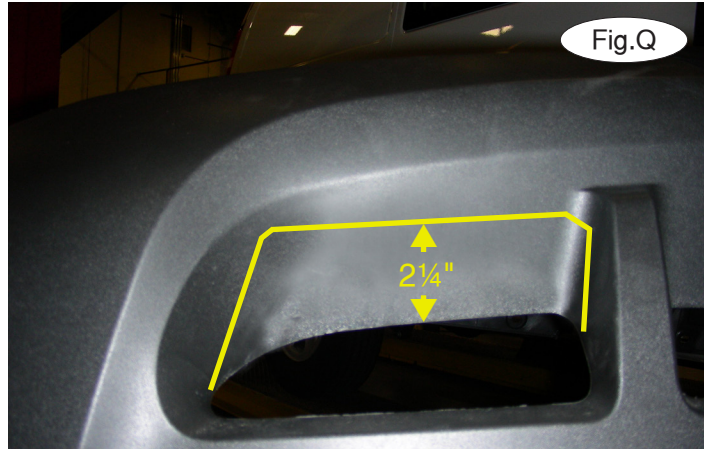

Fig.Q

BOLT TORQUE REQUIREMENTS

Note: The torque values represented below are intended as general guidelines. Torque requirements for specific applications may vary. Roadmaster does not warrant this information to be accurate for all applications and disclaims all liability for any claims or damages which may result from its use.

STANDARD BOLTS

Thread Size	Grade	Torque
5/16.....	5.....	13 ft./lb.
3/8.....	5.....	23 ft./lb.
7/16.....	5.....	37 ft./lb.
1/2.....	5.....	56 ft./lb.
5/8.....	5.....	150 ft./lb.

METRIC BOLTS

Thread Size	Grade	Plated / Unplated
8mm-1.0.....	8.8.....	20 ft./lb. 18 ft./lb.
8mm-1.25.....	8.8.....	19 ft./lb. 18 ft./lb.
10mm-1.25.....	8.8.....	38 ft./lb. 36 ft./lb.
10mm-1.5.....	8.8.....	37 ft./lb. 35 ft./lb.

METRIC BOLTS

Thread Size	Grade	Plated / Unplated
12mm-1.25.....	8.8.....	70 ft./lb. 65 ft./lb.
12mm-1.5.....	8.8.....	66 ft./lb. 61 ft./lb.
12mm-1.75.....	8.8.....	65 ft./lb. 60 ft./lb.
14mm-2.0.....	8.8.....	104 ft./lb. 97 ft./lb.

All illustrations and specifications contained herein are based on the latest information available at the time of publication approval. ROADMASTER, INC. reserves the right to make changes at any time without notice in material, specification and models or to discontinue models.