



BASEPLATE KIT INSTALLATION INSTRUCTIONS

KIT# 274-1

12/21/07

KS

ROADMASTER, Inc. 6110 NE 127th Ave. Vancouver, WA 98682 1-800-669-9690 fax 360-735-9300 www.roadmasterinc.com

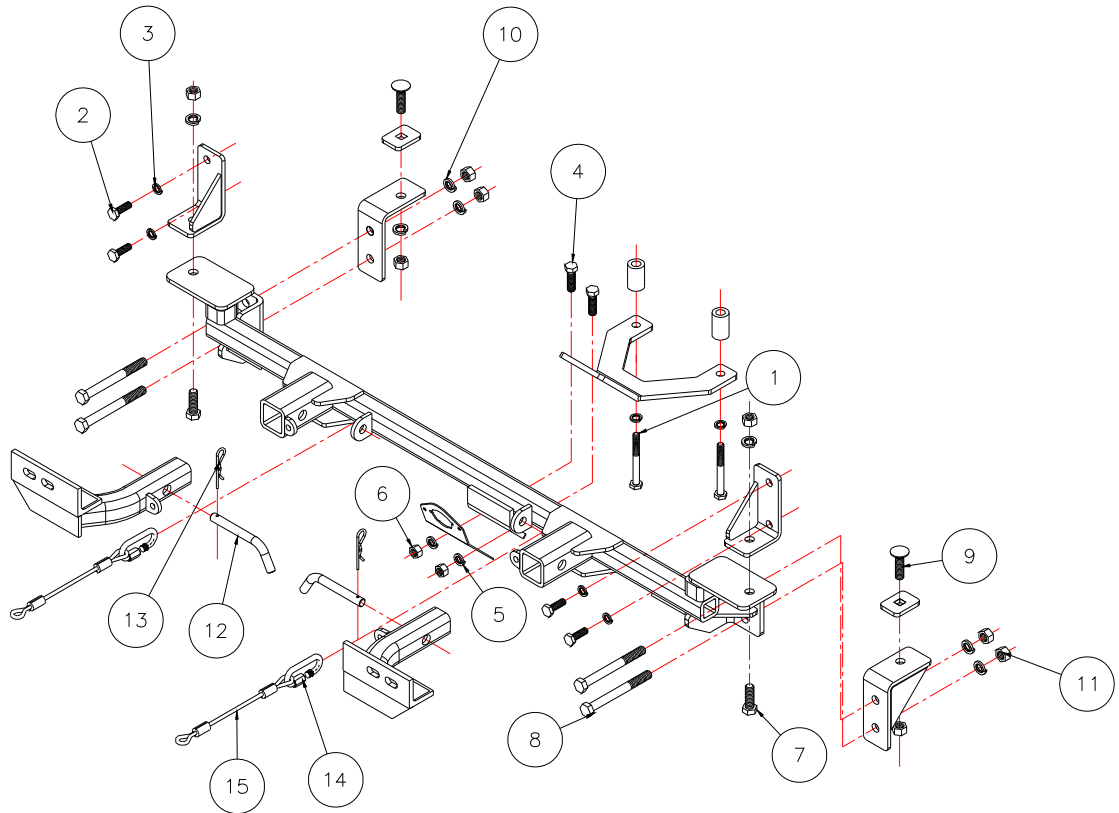

Item	Qty	Length	Width	Hardware	Part No.
1	2	85mm	10mm	10mm x 1.5 x 85mm BOLT	356112-00
2	4	30mm	10mm	10mm x 1.5 x 30mm BOLT	356101-00
3	6		10mm	LOCK WASHER	355715-00
4	2	1 1/2"	7/16"	7/16" x 1 1/2" BOLT	350074-00
5	2		7/16"	LOCK WASHER	350307-00
6	2		7/16"	NUT	350256-00
7	2	1 1/2"	1/2"	1/2" x 1 1/2" BOLT	350095-00
8	4	5"	1/2"	1/2" x 5" BOLT	350107-00
9	2	1 3/4"	1/2"	1/2" x 1 3/4" CARRIAGE BOLT	350363-00
10	8		1/2"	LOCK WASHER	350309-00
11	8		1/2"	NUT	350258-00
12	2		5/8"	DRAW PINS	357035-00
13	2		1/8"	SPRING PIN	357036-00
14	2			CABLE CONNECTOR	200008-00
15	2	13"		SAFETY CABLE	500646-13



BASEPLATE KIT INSTALLATION INSTRUCTIONS

KIT# 274-1

12/21/07

KS

ROADMASTER, Inc. 6110 NE 127th Ave. Vancouver, WA 98682 1-800-669-9690 fax 360-735-9300 www.roadmasterinc.com

Item	Qty	Name	Assembly
1	1	C-000935	MAIN BRACE
2	1	C-000940	DRIVER SIDE ARM WELDMENT
3	1	C-000941	PASSENGER SIDE ARM WELDMENT
4	1	C-000936	DRIVER SIDE INNER BUMPER BRACE
5	1	C-000937	PASSENGER SIDE INNER BUMPER BRACE
6	1	C-000938	DRIVER SIDE LOWER CORE SUPPORT BRACE
7	1	C-000939	PASSENGER SIDE LOWER CORE SUPPORT BRACE
8	1	B-000664	WIRE PLUG CONNECTOR BRACKET
9	1	B-000655	MOTOR MOUNT CENTER PLATE
10	2	A-0001442	1" x 1 5/8" x .219 TUBE SPACER
11	2	A-000039	1/4" x 1 1/2"x 2 BACKING PLATE

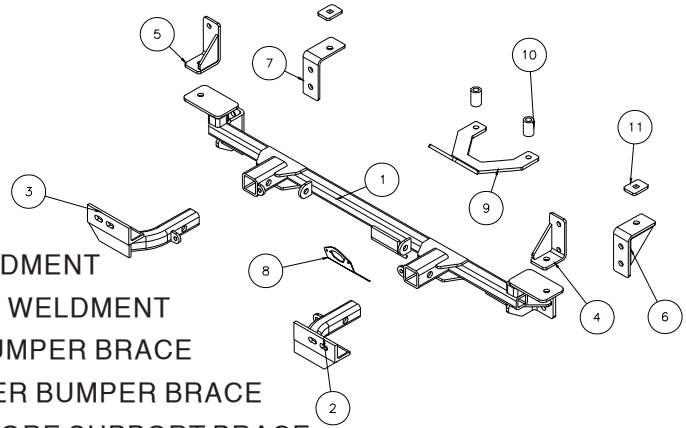

IMPORTANT: All baseplates **must** be assembled with all the bolts left loose for final adjustment and positioning (before tightening) unless otherwise instructed. All bolts **must** be torqued for proper strength. If more than one bolt is used per fastening point, the diagram may only show one. Use flat washers over all slotted holes and lock washers on all fasteners.

WARNING

Failure to heed these warnings or follow the installation instructions may result in a voided warranty, loss of towed vehicle, personal injury or death.

- Do not weld or modify this baseplate or its components. Welding or modification will void the warranty.
- Do not use this document as a basis to design/fabricate a baseplate, as it may not show all parts or structural components.
- We strongly recommend professional installation.
- If the towed vehicle has been in an accident, it must be properly repaired before attaching the baseplate. Do not install the baseplate if any structural frame damage is found.
- The installer must use all bolts and parts supplied. If running changes were made by the vehicle manufacturer after this kit was designed, some bolts or other fasteners may no longer be the correct size. It is the installer's responsibility to verify this kit is securely fastened to the vehicle.
- Use Loctite® Red on all bolts used to secure this baseplate. Torque all bolts to the specifications found at the end of these instructions. Do not over-torque the bolts or failure may occur.
- The installer must inspect the baseplate to ensure adequate clearance, particularly around hoses, air conditioner lines, radiators, etc. or non-warranty failure may result.
- Roadmaster manufactures many styles of baseplates. If your baseplate has removable arms, they must be removed before driving the vehicle, unless the arms can be pinned or padlocked in place. If not secured, the arms could vibrate out.
- Some motorhome chassis have such a tight turning radius that you can damage your motorhome, towed vehicle, tow bar or baseplate while turning sharply. Before getting on the road, test your turning radius in an empty parking lot. Turning too sharply could

result in non-warranty damage to your towing system, motorhome and/or towed vehicle.

- Do not back up with the towed vehicle attached or non-warranty damage will occur to your towing system or vehicles.
- The safety cables must connect the towing vehicle to the towed vehicle frame to frame, with the cables crossed, with enough slack for sharp turns. See cable instructions for proper routing. Failure to do so will result in non-warranty damage and/or the loss of the towed vehicle.
- This kit is designed for use with ROADMASTER tow bars and ROADMASTER adapters only. Using this kit with other brands, without an approved ROADMASTER adapter, may result in non-warranty damage or injury.
- Receiver extensions and out-of-level towing situations of 3 inches or more. This can cause the system to swing much higher and lower, causing excessive strain on the tow bar, baseplate and frame. That can cause the towing system to fail, causing property damage, personal injury or even death. If you must use a receiver extension or drop hitch to tow, it will reduce your receiver's weight capacity by 1/3 to avoid damaging your system. Never use more than one extension and/or drop hitch, as this will void your warranty.
- Every 3,000 miles, the owner must inspect all mounting points for cracks or fatigue, and check the fasteners for proper torque, according to the bolt torque requirements chart on the last page of these instructions.
- The owner must follow the vehicle manufacturer's instructions to prepare the vehicle for towing. Failure to do so may cause severe damage to the vehicle.
- This baseplate is only warranted for the original installation. Installing a used baseplate on another vehicle is not recommended and will void the warranty.



BASEPLATE KIT INSTALLATION INSTRUCTIONS

KIT# 274-1

12/21/07
KS

ROADMASTER, Inc. 6110 NE 127th Ave. Vancouver, WA 98682 1-800-669-9690 fax 360-735-9300 www.roadmasterinc.com

This is one of our XL bracket series, which allows the visible front portion of the brackets to be easily removed from the front of the vehicle (Fig.A). The bracket kit consists of a main receiver brace, front braces and a hardware pack. The rear receiver brace mounts to the front and side of the frame and protrudes through the lower grill below the bumper. Before starting the installation, lay out the kit components as illustrated. This will give you a visual idea of how the components work and also confirm that everything is present and accounted for.



1. **Important:** please use all supplied bolts and parts and read all instructions carefully before beginning this installation. The majority of questions you may have can be answered within the text, and proper installation will ensure safe and secure travel. Now, begin the installation. Begin by removing the front fascia and headlights starting with the headlights. Remove three screws (10mm head) from each headlight (Fig.B), pull forward then disconnect and set aside (Fig.C,D). Remove two 10mm (head) bolts from the top of the fascia between the headlights (Fig.E). Remove two 8mm (head) screws from each fender fascia junction (Fig.F), then two Phillips head screws in each fender well (Fig.G).

2. Remove a remaining bolt (8mm head) in the fascia fender junction on each side (Fig.H), then move to the bottom of the fascia and remove five plastic fasteners (Fig.I,J).

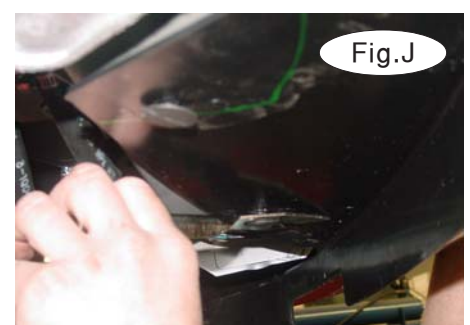



BASEPLATE KIT INSTALLATION INSTRUCTIONS

KIT# 274-1

12/21/07
KS

ROADMASTER, Inc. 6110 NE 127th Ave. Vancouver, WA 98682 1-800-669-9690 fax 360-735-9300 www.roadmasterinc.com



Fig.K



Fig.L



Fig.M

3. Pull the sides of the fascia out (Fig.K), then pull forward to remove and set aside (Fig.L).
4. Locate the radiator coolant reservoir on the drivers side and remove three 10mm (head) mounting bolts (Fig.M,N,O). Leave the reservoir hanging saving the bolts for reinstallation. Also pull the wiring harness loose from the frame to help with access (Fig.O).

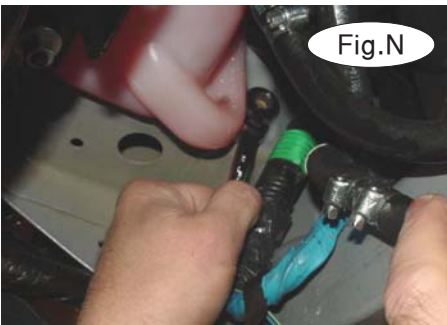

Fig.N



Fig.O

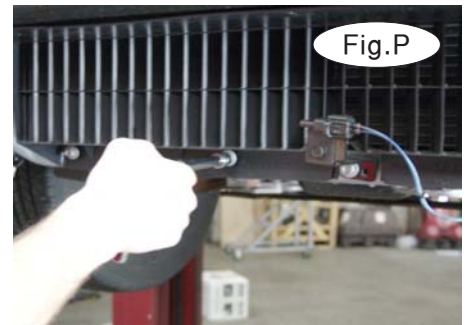

Fig.P

5. Some models are equipped with an extra guard between the fascia and the radiator, this will need to be removed. Remove three 10mm (head) bolts (Fig.P) and three plastic fasteners (Fig.Q) to remove the guard. The ambient temperature sensor needs to be temporarily removed as well (Fig.R-S).

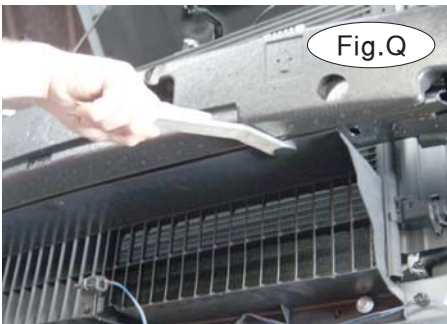

Fig.Q

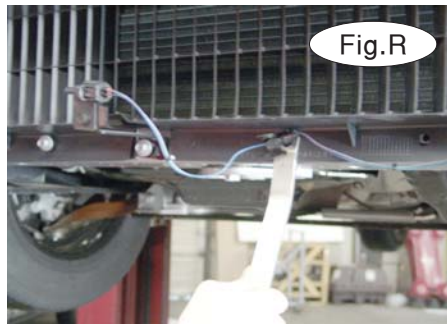

Fig.R

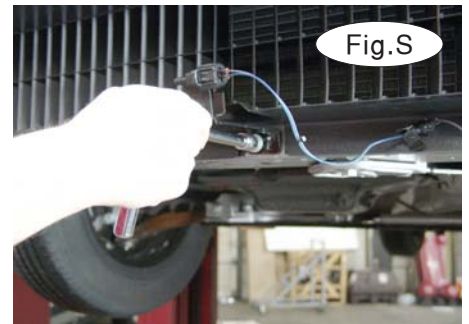

Fig.S

6. Move to the center engine mount and remove two side bolts leaving the center bolts in place (Fig.T).

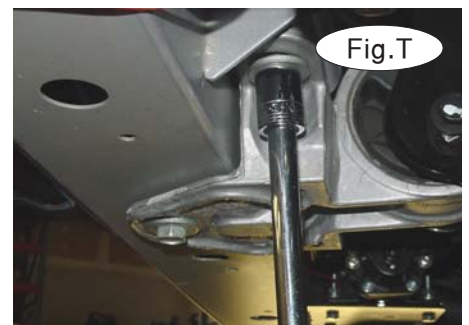

Fig.T



BASEPLATE KIT INSTALLATION INSTRUCTIONS

KIT# 274-1

12/21/07

KS

ROADMASTER, Inc. 6110 NE 127th Ave. Vancouver, WA 98682 1-800-669-9690 fax 360-735-9300 www.roadmasterinc.com

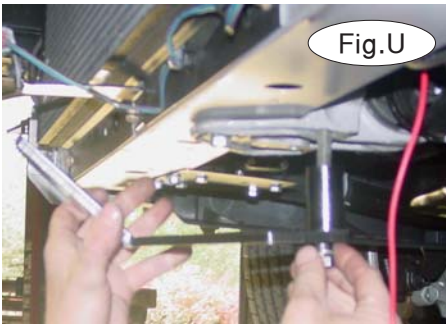

Fig.U



Fig.V

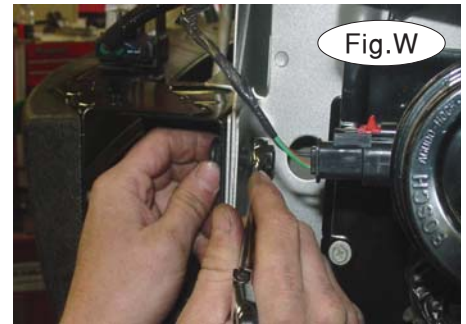

Fig.W

7. Bolt the lower motor mount center plate and 1 5/8" spacers over the engine mount with two 10mm x 1.50 x 85mm bolts and lock washers (Fig.U).

8. Find the ambient air sensor located on the bottom of the bumper core and relocate to clear the receiver brace (Fig.V).

9. Remove two carriage bolts and nuts (15mm) from the bumper core mounts on each side (Fig.W,X).

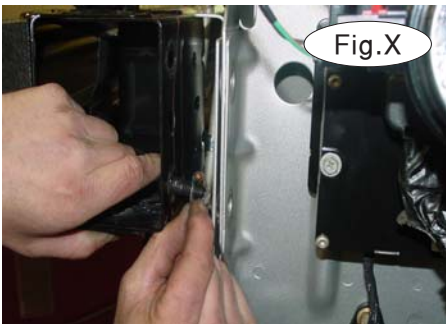

Fig.X

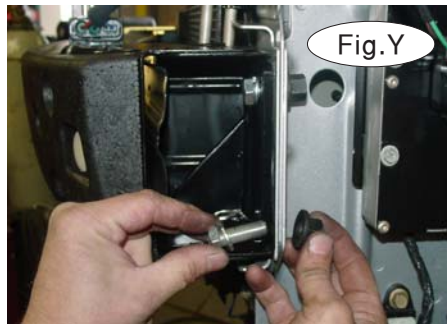

Fig.Y

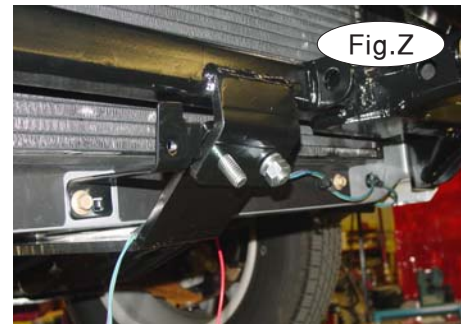

Fig.Z

10. Mount the inner bumper braces in the bumper core on each side with two supplied 10mm x 1.5 x 30mm bolts using the original shoulder nuts (Fig.Y). Leave loose for now.

11. Mount the main receiver brace on the motor mount center plate with two 7/16" x 1 1/2" bolts lock washers and nuts. Be sure to mount the wiring connector plate on these bolts also (Fig.Z).

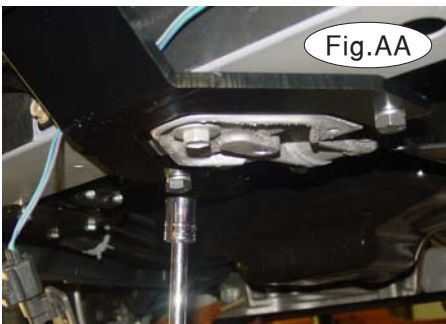

Fig.AA

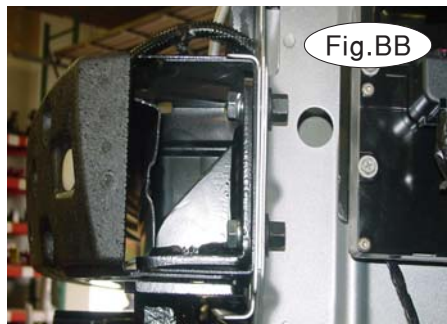

Fig.BB

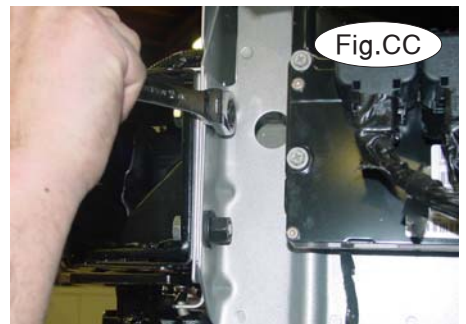

Fig.CC

12. Now tighten the mounting bolts in sequence starting with the lower motor mount plate bolts (Fig.AA). Push the bumper core up (Fig.BB) then tighten (Fig.CC). Align the main receiver brace under the bumper core with the rear of the brace against the frame and tighten the upper motor mount center plate bolts to hold the receiver brace in position (Fig.DD).

13. Using the lower receiver brace as a guide, drill a 17/32" hole through the bottom of the bumper core on each side (Fig.EE), then bolt through the receiver brace, bumper core and inner braces with 1/2" x 1 1/4" bolts, lock washers and nuts. Tighten these bolts (Fig.FF).



BASEPLATE KIT INSTALLATION INSTRUCTIONS

KIT# 274-1

12/21/07

KS

ROADMASTER, Inc. 6110 NE 127th Ave. Vancouver, WA 98682 1-800-669-9690 fax 360-735-9300 www.roadmasterinc.com



Fig.DD

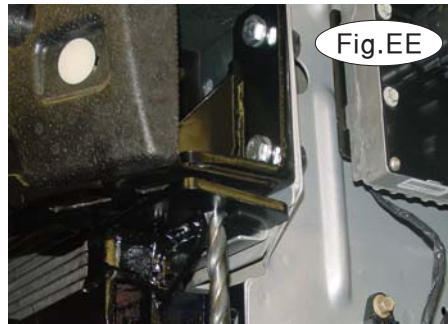

Fig.EE

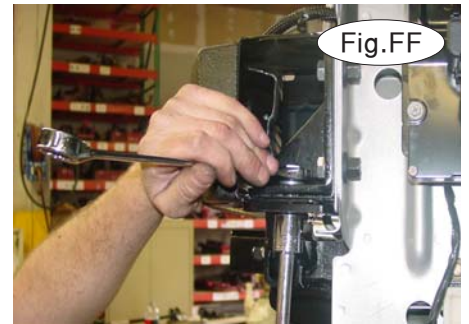

Fig.FF

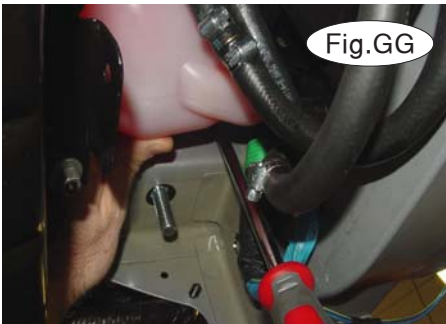

Fig.GG



Fig.HH

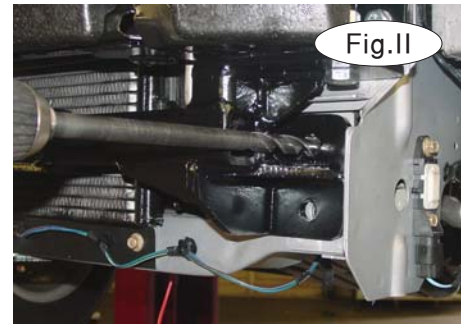

Fig.II

14. Referencing (Fig.GG), the screwdriver points to a access hole on the inside of the driver side frame beside the coolant reservoir dismantled in step 4. Push the reservoir away from the frame to insert a 1 1/2" x 2" backing plate and 1/2" x 1 1/2" carriage bolt into the existing hole in the bottom of the frame. Now do the same thing on the passenger side but access the existing hole through a access hole on the outside of the frame (Fig.HH). Align these core support braces with the existing hole in the back of the frame and tighten.

15. Moving to the front of the frame use two front mounting holes on each side of the receiver brace as a guide to drill two 7/16" holes through the front of the frame on each side (Fig.II). Now go to the rear of the frame and using the core support braces as a guide, drill additional top holes in the back of the frame on each side (Fig.JJ).

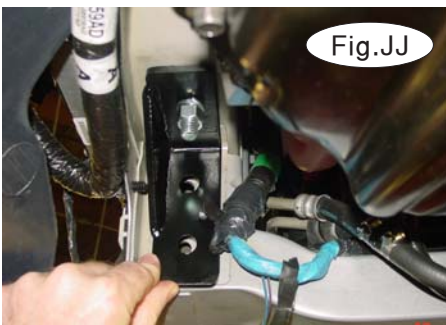

Fig.JJ

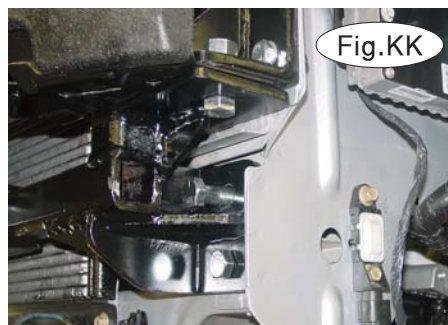

Fig.KK



Fig.LL

16. Bolt through the receiver brace, frame and rear core supports with two 1/2" x 5" bolts, lock washers and nuts on each side (Fig.KK,LL).



BASEPLATE KIT INSTALLATION INSTRUCTIONS

KIT# 274-1

12/21/07

KS

ROADMASTER, Inc. 6110 NE 127th Ave. Vancouver, WA 98682 1-800-669-9690 fax 360-735-9300 www.roadmasterinc.com



17. Now torque all the mounting bolts to the specifications below, then replace the radiator reservoir bolts removed in step 4.
18. Trim the lower center of the fascia as shown then reinstall reversing steps 1 through 3 (Fig.MM).
19. Insert the front braces into the receivers and pin with 5/8" draw pins and 3/16" spring pins (Fig.NN).
20. Mount the tow bar according to the tow bar manufacturer's instructions. Install the 13" safety cables on the main receiver cross bar with quick links provided (Fig.OO). Attach the other end to the tow vehicle's safety cables and the tow bar.

BOLT TORQUE REQUIREMENTS

Note: The torque values represented below are intended as general guidelines. Torque requirements for specific applications may vary. Roadmaster does not warrant this information to be accurate for all applications and disclaims all liability for any claims or damages which may result from its use.

STANDARD BOLTS

Thread Size	Grade	Torque
5/16	5	13 ft./lb.
3/8	5	23 ft./lb.
7/16	5	37 ft./lb.
1/2	5	56 ft./lb.
5/8	5	150 ft./lb.

METRIC BOLTS

Thread Size	Grade	Plated / Unplated
8mm-1.0	8.8	20 ft./lb. 18 ft./lb.
8mm-1.25	8.8	19 ft./lb. 18 ft./lb.
10mm-1.25	8.8	38 ft./lb. 36 ft./lb.
10mm-1.5	8.8	37 ft./lb. 35 ft./lb.

METRIC BOLTS

Thread Size	Grade	Plated / Unplated
12mm-1.25	8.8	70 ft./lb. 65 ft./lb.
12mm-1.5	8.8	66 ft./lb. 61 ft./lb.
12mm-1.75	8.8	65 ft./lb. 60 ft./lb.
14mm-2.0	8.8	104 ft./lb. 97 ft./lb.

All illustrations and specifications contained herein are based on the latest information available at the time of publication approval. ROADMASTER, INC. reserves the right to make changes at any time without notice in material, specification and models or to discontinue models.