



# MOUNTING BRACKET KIT INSTALLATION INSTRUCTIONS

**KIT# 278-1**

09/14/05  
KB

ROADMASTER, Inc. 6110 NE 127th Ave. Vancouver, WA 98682 1-800-669-9690 fax 360-735-9300 www.roadmasterinc.com

ROADMASTER, INC.

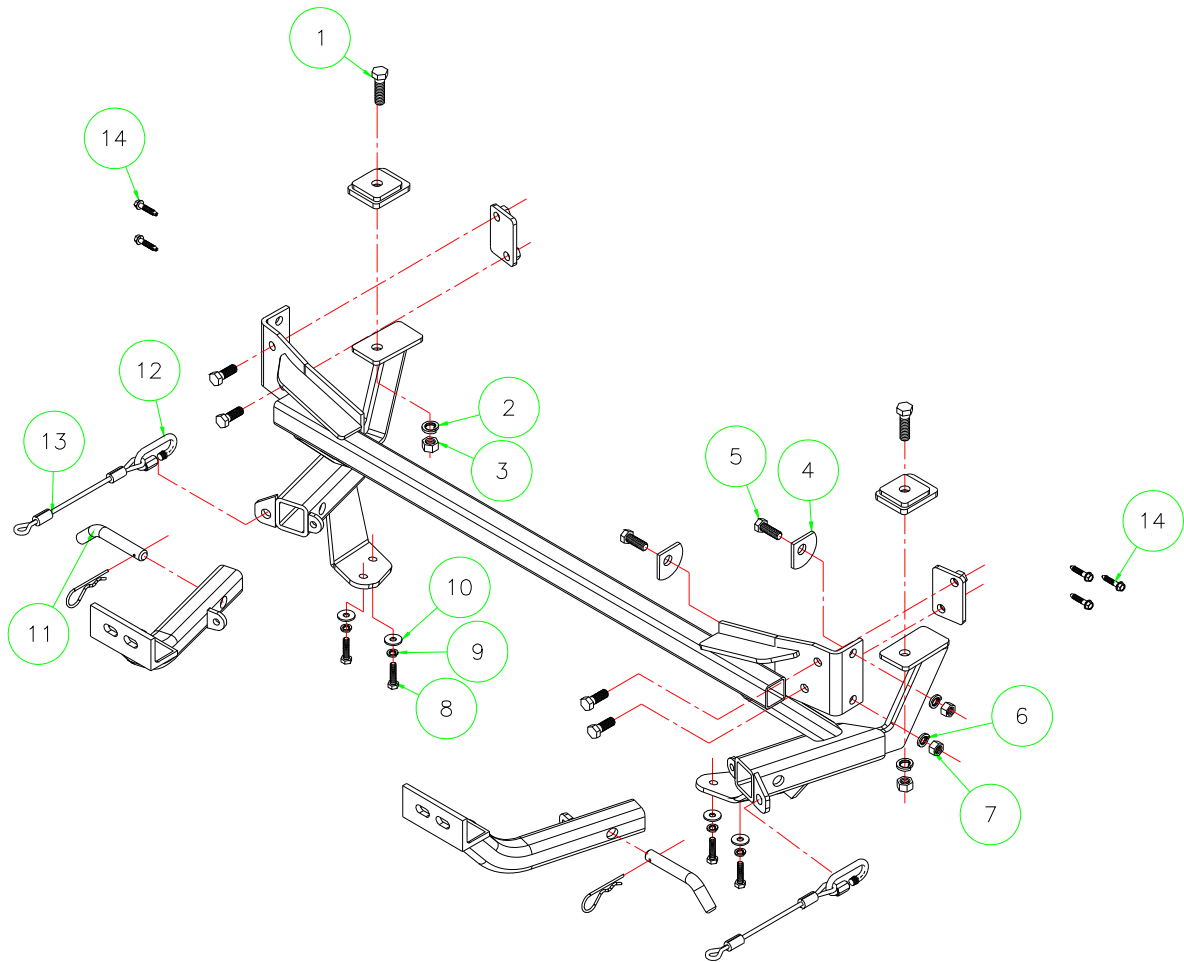

Item	Qty.	Length	Width	Description	Part #
1	2	1 3/4"	1/2"	BOLT	350096-00
2	2		1/2"	LOCKWASHER	350309-00
3	2		1/2"	NUTS	350258-00
4	2		1/2"	CLIPPED PLATE WASHER	350351-00
5	6	1 1/4"	7/16"	BOLT	350073-00
6	6		7/16"	LOCKWASHER	350307-00
7	2		7/16"	NUTS	350256-00
8	4	1.25	8mm	8mm x 1.25 x 30mm BOLT	356001-00
9	4		8mm	8mm LOCK WASHER	355705-00
10	4		8mm	8mm FENDER WASHER	355702-00
11	2			DRAW PIN/SPRING PIN	357035-00
12	2			CABLE CONNECTOR	200008-00
13	2	8"		8" SAFETY CABLES	500646-08
14	5	3/4"	1/4"	SELF TAPPING SCREW	350271-00



# MOUNTING BRACKET KIT INSTALLATION INSTRUCTIONS

## KIT# 278-1

09/14/05  
KB

ROADMASTER, Inc. 6110 NE 127th Ave. Vancouver, WA 98682 1-800-669-9690 fax 360-735-9300 www.roadmasterinc.com

**IMPORTANT:** All brackets **must** be assembled with all the bolts left loose for final adjustment & positioning (before tightening) unless otherwise instructed. All bolts **must** be torqued for proper strength. If more than one bolt is used per fastening point, the diagram may only show one.

- Use flat washers over all slotted holes
- Use lock washers on all fasteners

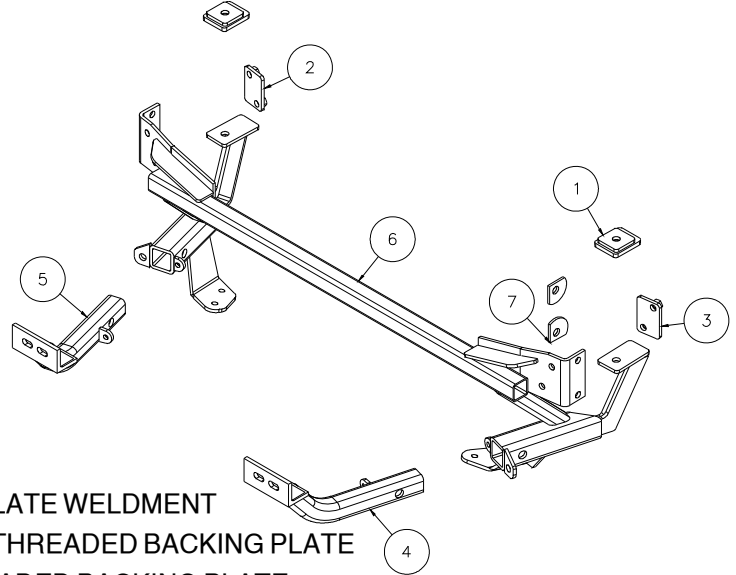

Item	Qty.	Part #	Assembly
1	2	C-001154	UPPER BACKING PLATE WELDMENT
2	1	C-001152	PASSENGER SIDE THREADED BACKING PLATE
3	1	C-001153	DRIVER SIDE THREADED BACKING PLATE
4	1	C-001149	DRIVER SIDE ARM BRACE WELDMENT
5	1	C-001150	PASSENGER SIDE ARM BRACE WELDMENT
6	1	C-001151	MAIN RECEIVER BRACE WELDMENT
7	2	A-001850	CLIPPED PLATE WASHER

ROADMASTER Limited Warranty, including One-Year Conditional Warranty Text and Product Registration Card, in Carton.

## WARNING

- Do not use this document for custom fabrication, as it may not show all parts or structural components. Custom fabrication or an attempt to copy this bracket design could result in loss of the towed vehicle.
- The owner must inspect all mounts and brackets before each use for cracks or other signs of fatigue. Also, inspect the fasteners for proper torque, according to the bolt torque requirements chart on the last page. Failure to do so could result in loss of the towed vehicle.
- The owner must check the manufacturer's instructions for the proper procedure(s) to prepare the vehicle for towing. Some vehicles must be equipped with a transmission lube pump, an axle disconnect, driveline disconnect or free-wheeling hubs before they can be towed. Failure to properly equip the vehicle will cause severe damage to the transmission.
- The installer must read the instructions and use all bolts and parts supplied. Failure to securely fasten the bracket could result in loss of the towed vehicle.
- If running changes were made by the vehicle manufacturer after this bracket was designed, some bolts or other fasteners in the included hardware pack may no longer be the correct size. It is the installer's responsibility to verify that the bracket is securely fastened to the vehicle, and fitted with the correct hardware, to account for these changes. Failure to securely fasten the bracket could result in loss of the towed vehicle.
- If the towed vehicle has been in an accident, it must be properly repaired before attaching the bracket. Do not install the bracket if any structural frame damage is found. Failure to repair the damage may result in the loss of the towed vehicle.

- Some motorhome chassis have such a tight turning radius that you can damage your motorhome, towed vehicle, tow bar or bracket while turning sharply. Before getting on the road, test your turning radius in an empty parking lot. Turning too sharply could result in non-warranty damage to towing system, motorhome and/or towed vehicle.
- Do not back up with the towed vehicle attached or non-warranty damage will occur to your towing system, motorhome and/or towed vehicle.
- The safety cables must connect the towing vehicle to the towed vehicle frame to frame, with the cables crossed, with enough slack for sharp turns. Refer to the cable instructions for proper routing. Failure to leave enough slack in the safety cables, or failure to connect the safety cables frame to frame, will result in the loss of the towed vehicle.
- This bracket is designed for use with ROADMASTER tow bars and ROADMASTER adaptors only. Using this bracket with other brands, without an approved ROADMASTER adaptor, may result in non-warranty damage or injury.
- Upon final installation, the installer must inspect the bracket to ensure adequate clearance, particularly around hoses, air conditioner lines, radiators, etc., or non-warranty damage to the towed vehicle will result.
- This bracket is only warranted for the original installation. Installing a used bracket on another vehicle is not recommended and will void the warranty.

## WARNING

Failure to follow these instructions can result in property damage, personal injury or even death.



# MOUNTING BRACKET KIT INSTALLATION INSTRUCTIONS

**KIT# 278-1**

09/14/05  
KB

ROADMASTER, Inc. 6110 NE 127th Ave. Vancouver, WA 98682 1-800-669-9690 fax 360-735-9300 www.roadmasterinc.com

This is one of our XL series brackets, which allows the visible front portion of the brackets to be easily removed from the front of the vehicle (Fig.A). The bracket kit consists of a main brace with two receiver braces, two removable front bracket arms, a hardware pack and a fascia trimming template. The receiver braces and the removable front bracket arms protrude through the lower fascia on each side, below the bumper. The front bracket arms are inserted into the receiver braces and secured with draw pins and spring pins.



Before starting the installation, lay out the kit components in order, as they will be used. This will give you a visual idea of how the components work, and will also confirm that everything is present and accounted for.



1. Begin by removing the four 7mm (head) bolts located across the top of the grille (Fig.B)
2. Pull out on the grille and remove it (Fig.C).
3. Remove the two 7mm (head) bolts on the fascia (Fig.D).



4. Remove the three 7mm (head) bolts which attach the fascia to the bottom of the radiator support. They are located near the center (Fig.E). Then, remove the small press washer on the lower fascia, on the driver's side (Fig.F).

5. On each side, remove the three 7mm bolts along the edge of the fender wells (Fig.G).
6. Pull the fender liner back to gain access to the 10mm nuts (two on each side), and remove them (Fig.H).

7. Disconnect the fog lights, if the vehicle is so equipped.

8. Pull down and forward on the fascia to remove it (Fig.I).





# MOUNTING BRACKET KIT INSTALLATION INSTRUCTIONS

**KIT# 278-1**

09/14/05  
KB

ROADMASTER, Inc. 6110 NE 127th Ave. Vancouver, WA 98682 1-800-669-9690 fax 360-735-9300 www.roadmasterinc.com



9. On earlier models, the vehicle's computer is mounted to the side of the frame. If this is the case, remove the three 10mm (head) mounting bolts holding the computer in place. Let the computer hang down to provide access to the inside of the frame.

10. On the passenger side, remove two 10mm (head) bolts holding the vacuum storage bottle (Fig.J), and remove the vacuum storage bottle.

11. Remove the air deflector on the passenger side – remove one plastic fastener (Fig.K) and four 10mm (head) bolts, one below the radiator (Fig.L) and three along the bottom of the frame rail.

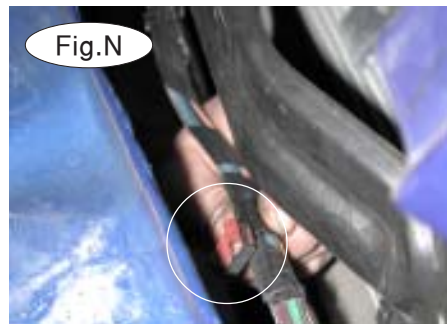

12. Remove the air deflector on the driver's side by removing two plastic fasteners (Fig.M)

13. Remove the bumper core – First, unfasten the two metal clips and the two plastic fasteners from the wiring harness at the rear of the bumper core. Then remove six 13mm head bolts from the bumper core (Fig.O). The bracket will replace the factory bumper core. *Note:* retain the bumper core and attachment hardware so that it can be replaced if the bracket is ever removed.

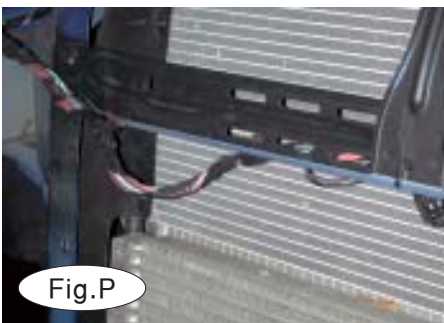

14. Reattach the wiring harness to the hood latch support cross brace (Fig.P).

15. On each side, remove two slip nuts from the end of the frame rail (Fig.Q).

16. Brace the radiator support (Fig.R).



# MOUNTING BRACKET KIT INSTALLATION INSTRUCTIONS

**KIT# 278-1**

09/14/05  
KB

ROADMASTER, Inc. 6110 NE 127th Ave. Vancouver, WA 98682 1-800-669-9690 fax 360-735-9300 www.roadmasterinc.com



Fig.S

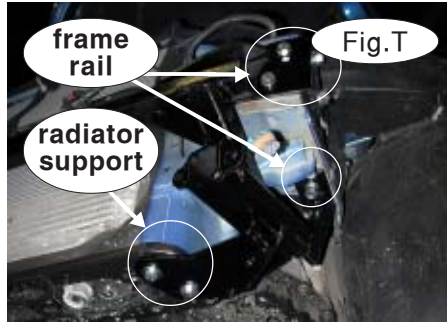

Fig.T

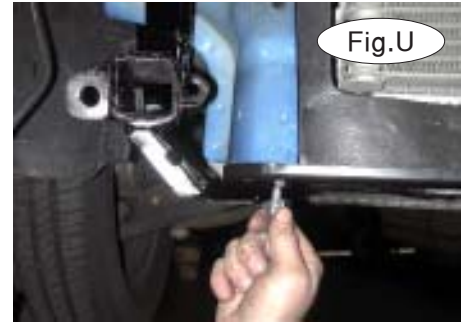

Fig.U

17. Remove four 13mm (head) bolts, two on each side, from the bottom of the radiator support (Fig.S).
18. On each side, the bracket will be bolted to the radiator support and at three points on the frame rail. Use Figure T, which shows all of the passenger side bolts in place, as a reference for the following seven steps.
19. Bolt the main brace to the bottom of the radiator support – on each side, use two of the supplied 8mm x 1.25 x 30mm bolts, fender washers and lock washers, and thread the bolts into the holes for the bolts you removed in step 17 (Fig.U). Finger-tighten only at this time.

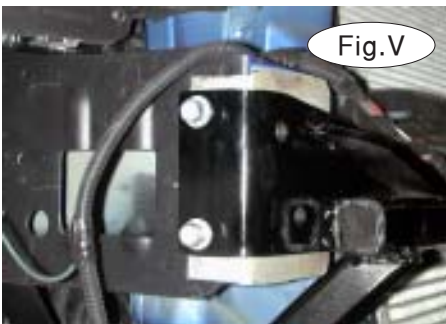

Fig.V



Fig.W



Fig.X

20. On the passenger side frame rail, thread two of the 13mm factory bolts you removed from the bumper core in step 13 into the side of the main brace (Fig.V). Finger tighten only.
21. Bolt the front of the main brace to the frame rail – there are two 2" x 3" nutted backing plates, one for each side. Line up the pre-drilled holes to identify the driver's side plate, then position it inside the frame rail (Fig.W). Thread a 7/16" x 1 1/4" bolt and a 7/16" lock washer and through both of the holes, and finger-tighten. Repeat for the passenger side (Fig.X). (Holes may have to be reamed with a 1/2" drill bit.)

22. Attach the rear brace to the frame rail – drop one of the supplied 2 3/4" x 1 3/4" backing plates and 1/2" x 1 3/4" bolts into the pre-existing hole in the frame (Fig.Y). From the bottom, thread a 1/2" lock washer and nut onto the bolt to hold it in place (Fig.Z). Repeat on the other side.



Fig.Y



Fig.Z

23. Tighten all bolts to the torque specifications at the end of these instructions.



# MOUNTING BRACKET KIT INSTALLATION INSTRUCTIONS

**KIT# 278-1**

09/14/05  
KB

ROADMASTER, Inc. 6110 NE 127th Ave. Vancouver, WA 98682 1-800-669-9690 fax 360-735-9300 www.roadmasterinc.com

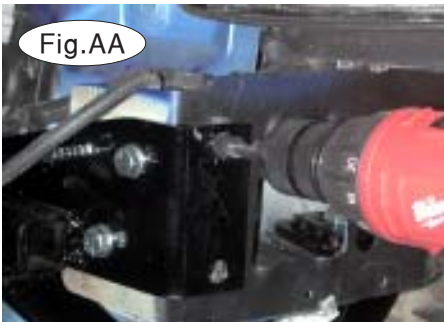

24. Using the holes in the bracket as a template, drill two holes through the driver's side frame rail with a 1/2" drill bit (Fig.AA).

25. Fit one of the supplied 7/16" x 1 1/4" bolts through one of the cut 1/2" plate washers and, from the inside of the frame rail, slide the bolt through one of the 1/2" holes you drilled in the previous step (Fig.BB). From the outside of the frame rail, thread a 7/16" lock washer and nut onto the bolt to secure it in place (Fig.CC), and torque the bolt to the specifications at the bottom of these instructions. Repeat for the other drilled hole.



26. Trim the driver's side air deflector (Fig.DD) and the passenger side air deflector (Fig.EE) to accommodate the bracket. Use the white outlines as a reference. Then, replace the air deflectors (steps 11 and 12).

27. Replace the vacuum storage bottle, 1/2" farther back than its original location. Use two of the supplied 1/4" x 3/4" self-tapping screws (Fig.FF).

28. If it was necessary to remove the vehicle's computer from the side of the frame, reattach it – to accommodate the bracket, mount the computer approx. 3/4" farther back from its original location. First, bend the line up tab on each side of the computer down (Fig.GG). Then, use three of the supplied 1/4" x 3/4" self-tapping screws to reattach the computer to the side of the frame (Fig.HH).





# MOUNTING BRACKET KIT INSTALLATION INSTRUCTIONS

**KIT# 278-1**

09/14/05  
KB

ROADMASTER, Inc. 6110 NE 127th Ave. Vancouver, WA 98682 1-800-669-9690 fax 360-735-9300 www.roadmasterinc.com



Fig.II



Fig.JJ



Fig.KK

29. On **2005 and older models**, use one of the templates on the last page of these instructions to trim the section of fascia indicated in Figures II and JJ, so that the receiver arm will fit through (Fig.KK). Repeat for the other side. Test-fit the fascia and trim more material, if required. **2006 models** have a removable plastic grille insert. Hold fascia in place, mark grille and trim (Fig.MM-NN).
30. Reinstall the fascia by reversing steps 1 through 8.
31. Fit the front bracket arms into the front receiver braces, and secure them in place with the supplied 5/8" draw pins and spring pins.
32. Attach the 8" safety cables with the cable connectors (Q-Links) to the front of the receiver braces (Fig.LL).
33. Attach the ends of the safety cables to the tow vehicle's safety cables and tow bar.
34. Install the tow bar to the mounting bracket according to the manufacturer's instructions.



Fig.LL



Fig.MM



Fig.NN

## BOLT TORQUE REQUIREMENTS

Note: The torque values represented below are intended as general guidelines. Torque requirements for specific applications may vary. Roadmaster does not warrant this information to be accurate for all applications and disclaims all liability for any claims or damages which may result from its use.

### STANDARD BOLTS

Thread Size	Grade	Torque
5/16	5	13 ft./lb.
3/8	5	23 ft./lb.
7/16	5	37 ft./lb.
1/2	5	56 ft./lb.
5/8	5	150 ft./lb.

### METRIC BOLTS

Thread Size	Grade	Plated/Unplated
8mm-1.0	8.8	20 ft./lb. 18 ft./lb.
8mm-1.25	8.8	19 ft./lb. 18 ft./lb.
10mm-1.25	8.8	38 ft./lb. 36 ft./lb.
10mm-1.5	8.8	37 ft./lb. 35 ft./lb.

### METRIC BOLTS

Thread Size	Grade	Plated/Unplated
12mm-1.25	8.8	70 ft./lb. 65 ft./lb.
12mm-1.5	8.8	66 ft./lb. 61 ft./lb.
12mm-1.75	8.8	65 ft./lb. 60 ft./lb.
14mm-2.0	8.8	104 ft./lb. 97 ft./lb.

All illustrations and specifications contained herein are based on the latest information available at the time of publication approval. ROADMASTER, INC. reserves the right to make changes at any time without notice in material, specification and models or to discontinue models.



# MOUNTING BRACKET KIT INSTALLATION INSTRUCTIONS

**KIT# 278-1**

09/14/05  
KB

ROADMASTER, Inc. 6110 NE 127th Ave. Vancouver, WA 98682 1-800-669-9690 fax 360-735-9300 www.roadmasterinc.com

## Fascia trim templates

(Refer to step 29.)

