



# BASEPLATE KIT INSTALLATION INSTRUCTIONS

**KIT# 3115-3**

05/07/13  
KS

ROADMASTER, Inc. 6110 NE 127th Ave. Vancouver, WA 98682 360-896-0407 fax 360-735-9300 www.roadmasterinc.com

**Important**

Note: this bracket will not accommodate the Guardian rock shield, some models of the Tow Defender, Stowaway or the StowMaster and StowMaster All Terrain tow bars.

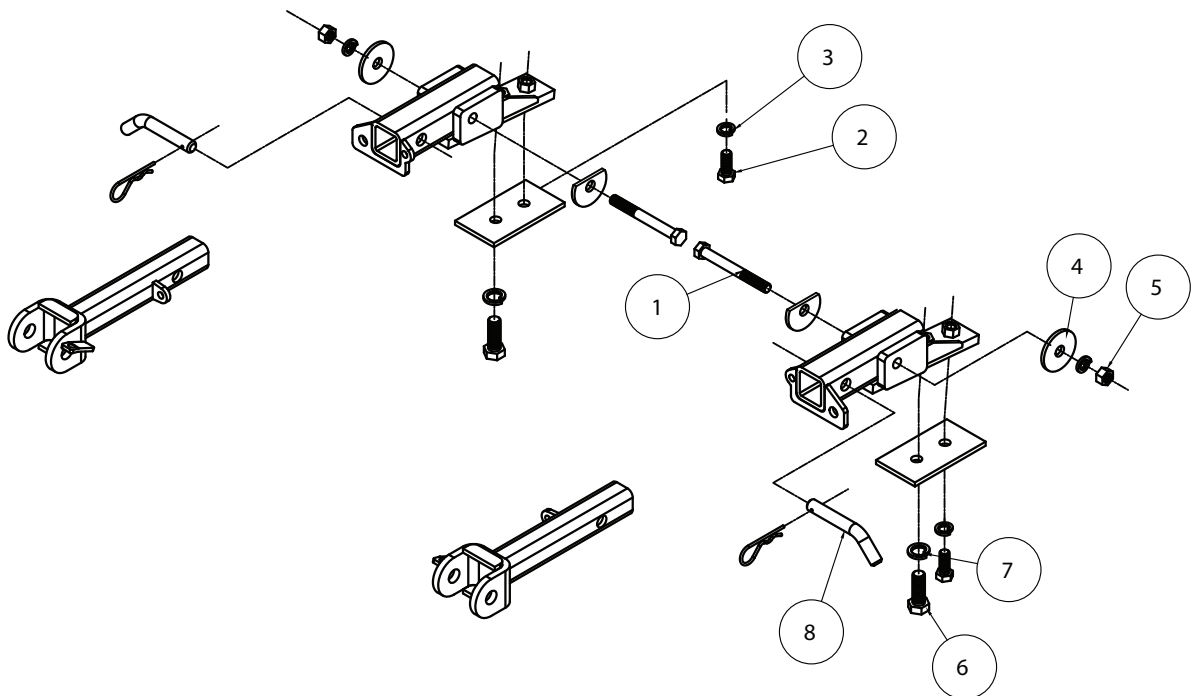

| Item | Qty. | Length | Width  | Description           | Part #    |
|------|------|--------|--------|-----------------------|-----------|
| 1    | 2    | 5"     | 5/8"   | 5/8" x 5" BOLT        | 350160-00 |
| 2    | 2    | 1 3/4" | 1/2"   | 1/2" x 1 3/4" BOLT    | 350096-00 |
| 3    | 2    |        | 1/2"   | LOCK WASHER           | 350309-00 |
| 4    | 2    |        | 2 1/2" | 5/8" PLATE WASHER     | 350352-00 |
| 5    | 2    |        | 5/8"   | NUT                   | 350262-00 |
| 6    | 2    | 1 3/4" | 5/8"   | BOLT                  | 350149-00 |
| 7    | 4    |        | 5/8"   | LOCK WASHER           | 350313-00 |
| 8    | 2    |        |        | DRAW PIN / SPRING PIN | 357035-00 |



# BASEPLATE KIT INSTALLATION INSTRUCTIONS

**KIT# 3115-3**

05/07/13  
KS

ROADMASTER, Inc. 6110 NE 127th Ave. Vancouver, WA 98682 360-896-0407 fax 360-735-9300 www.roadmasterinc.com

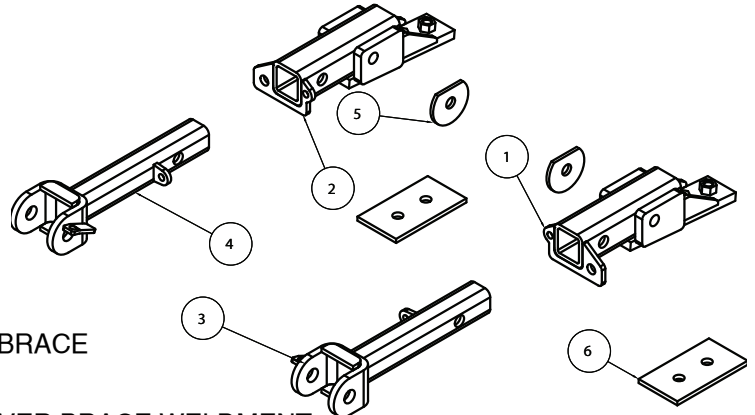

| Item   | Qty. | Part #        | Description                            |
|--------|------|---------------|--|
| 1..... | 1    | C-000526..... | DRIVER SIDE RECEIVER BRACE WELDMENT    |
| 2..... | 1    | C-000527..... | PASSENGER SIDE RECEIVER BRACE WELDMENT |
| 3..... | 1    | C-000557..... | DRIVER SIDE ARM WELDMENT               |
| 4..... | 1    | C-000558..... | PASSENGER SIDE ARM WELDMENT            |
| 5..... | 2    | A-001763..... | 5/8" CLIPPED PLATE WASHER              |
| 6..... | 2    | A-001995..... | 1/4" X 2 3/4" X 5" PLATE               |

**IMPORTANT:** All baseplates **must** be assembled with all the bolts left loose for final adjustment and positioning (before tightening) unless otherwise instructed. All bolts **must** be torqued for proper strength. If more than one bolt is used per fastening point, the diagram may only show one. Use flat washers over all slotted holes and lock washers on all fasteners.

## WARNING

Failure to heed these warnings or follow the installation instructions may result in a voided warranty, loss of towed vehicle, personal injury or death.

- Do not weld or modify this baseplate or its components. Welding or modification will void the warranty.
- Do not use this document as a basis to design/fabricate a baseplate, as it may not show all parts or structural components.
- We strongly recommend professional installation.
- If the towed vehicle has been in an accident, it must be properly repaired before attaching the baseplate. Do not install the baseplate if any structural frame damage is found.
- The installer must use all bolts and parts supplied. If running changes were made by the vehicle manufacturer after this kit was designed, some bolts or other fasteners may no longer be the correct size. It is the installer's responsibility to verify this kit is securely fastened to the vehicle.
- Use Loctite® Red on all bolts used to secure this baseplate. Torque all bolts to the specifications found at the end of these instructions. Do not over-torque the bolts or failure may occur.
- The installer must inspect the baseplate to ensure adequate clearance, particularly around hoses, air conditioner lines, radiators, etc. or non-warranty failure may result.
- Roadmaster manufactures many styles of baseplates. If your baseplate has removable arms, they must be removed before driving the vehicle, unless the arms can be pinned or padlocked in place. If not secured, the arms could vibrate out.
- Some motorhome chassis have such a tight turning radius that you can damage your motorhome, towed vehicle, tow bar or baseplate while turning sharply. Before getting on the road, test your turning radius in an empty parking lot. Turning too sharply could

result in non-warranty damage to your towing system, motorhome and/or towed vehicle.

- Do not back up with the towed vehicle attached or non-warranty damage will occur to your towing system or vehicles.
- The safety cables must connect the towing vehicle to the towed vehicle frame to frame, with the cables crossed, with enough slack for sharp turns. See cable instructions for proper routing. Failure to do so will result in non-warranty damage and/or the loss of the towed vehicle.
- This kit is designed for use with ROADMASTER tow bars and ROADMASTER adapters only. Using this kit with other brands, without an approved ROADMASTER adapter, may result in non-warranty damage or injury.
- Receiver extensions and out-of-level towing situations of 3 inches or more. This can cause the system to swing much higher and lower, causing excessive strain on the tow bar, baseplate and frame. That can cause the towing system to fail, causing property damage, personal injury or even death. If you must use a receiver extension or drop hitch to tow, it will reduce your receiver's weight capacity by 1/3 to avoid damaging your system. Never use more than one extension and/or drop hitch, as this will void your warranty.
- Every 3,000 miles, the owner must inspect all mounting points for cracks or fatigue, and check the fasteners for proper torque, according to the bolt torque requirements chart on the last page of these instructions.
- The owner must follow the vehicle manufacturer's instructions to prepare the vehicle for towing. Failure to do so may cause severe damage to the vehicle.
- This baseplate is only warranted for the original installation. Installing a used baseplate on another vehicle is not recommended and will void the warranty.



# BASEPLATE KIT INSTALLATION INSTRUCTIONS

**KIT# 3115-3**

05/07/13  
KS

ROADMASTER, Inc. 6110 NE 127th Ave. Vancouver, WA 98682 360-896-0407 fax 360-735-9300 www.roadmasterinc.com

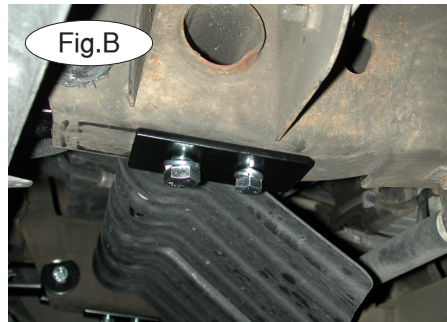
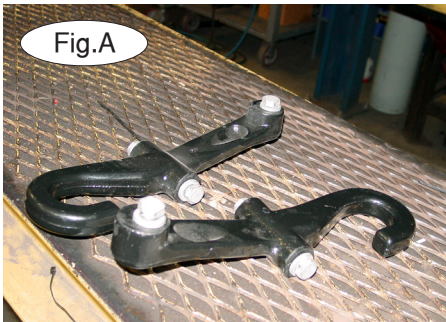

This bracket kit is one of our MX series, which allows the visible front portion of the brackets to be easily removed from the front of the vehicle. The kit consists of two receiver braces, two front braces and a hardware pack. The main receiver braces mount in the front of the frame tubes to the same mounting points as the factory tow hooks. The tow hooks are removed and replaced with the receiver braces. The front braces insert into the receivers on each side.

Before starting the installation, lay out the kit components in order, as they will be used. This will give you a visual idea of how the components work, and will also confirm that everything is present and accounted for.

**Note: for the 2007-2013 Chevrolet Suburban 2500 and 2007 GMC Yukon 2500, follow the supplemental instructions on the next page for step 1.**

1. **Important: please use all supplied bolts and parts and read all instructions carefully before beginning this installation. The majority of questions you may have can be answered within the text, and proper installation will ensure safe and secure travel.** Now, begin the installation by removing the front stock tow hooks (three bolts) on each side (Fig.B).

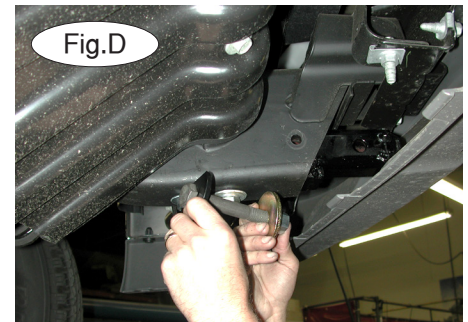

2. Insert the receiver braces in the front of the frame tubes on each side over the tow hook mounting holes.
3. Working on one side at a time, bolt the receiver braces in place, using a 1/2" x 1 3/4" bolt, lock washer and 1/4" x 2 3/4" x 5" backing plate (holes are 21/32" and 9/16") in the bottom rear mounting hole and a 5/8" x 1 3/4" bolt and lock washer in the front bottom mounting hole (Fig.C). Leave the bottom bolts loose for the next step.
4. Using a 5/8" drill bit or die grinder, enlarge the existing holes in the frame to 5/8" (Fig.D).
5. Bolt through the holes with the 5/8" x 5" bolt, plate washer, lock washer and nut (Fig.E). *Note: the cut plate washer goes to the inside of the frame, on both sides.*
6. Repeat steps 4 and 5 for the remaining side then torque all mounting bolts to the specifications at the bottom of these instructions.
7. Fit the front bracket arms into the front receiver braces, and secure them in place with the supplied 5/8" draw pins and spring pins. *Note: for the 2007-2013 Chevrolet Suburban 2500 and 2007 GMC Yukon 2500, the draw pins install from underneath the fascia.*
8. Install the tow bar to the mounting bracket according to the manufacturer's instructions. Attach the safety cables to the main receiver brace.

## BOLT TORQUE REQUIREMENTS

Note: The torque values represented below are intended as general guidelines. Torque requirements for specific applications may vary. Roadmaster does not warrant this information to be accurate for all applications and disclaims all liability for any claims or damages which may result from its use.

### STANDARD BOLTS

| Thread Size | Grade | Torque      |
|-------------|-------|-------------|
| 5/16        | 5     | 13 ft./lb.  |
| 3/8         | 5     | 23 ft./lb.  |
| 7/16        | 5     | 37 ft./lb.  |
| 1/2         | 5     | 56 ft./lb.  |
| 5/8         | 5     | 150 ft./lb. |

### METRIC BOLTS

| Thread Size | Grade | Plated / Unplated     |
|-------------|-------|-----------------------|
| 8mm-1.0     | 8.8   | 20 ft./lb. 18 ft./lb. |
| 8mm-1.25    | 8.8   | 19 ft./lb. 18 ft./lb. |
| 10mm-1.25   | 8.8   | 38 ft./lb. 36 ft./lb. |
| 10mm-1.5    | 8.8   | 37 ft./lb. 35 ft./lb. |

### METRIC BOLTS

| Thread Size | Grade | Plated / Unplated      |
|-------------|-------|------------------------|
| 12mm-1.25   | 8.8   | 70 ft./lb. 65 ft./lb.  |
| 12mm-1.5    | 8.8   | 66 ft./lb. 61 ft./lb.  |
| 12mm-1.75   | 8.8   | 65 ft./lb. 60 ft./lb.  |
| 14mm-2.0    | 8.8   | 104 ft./lb. 97 ft./lb. |



# BASEPLATE KIT INSTALLATION INSTRUCTIONS

**KIT# 3115-3**

05/07/13  
KS

ROADMASTER, Inc. 6110 NE 127th Ave. Vancouver, WA 98682 360-896-0407 fax 360-735-9300 www.roadmasterinc.com

## 2007-2013 Chevrolet Suburban 2500 and 2007 GMC Yukon 2500 Supplemental Instructions

1. Start by removing the front stock tow hooks (two bolts) on each side.
2. Now, trim the tow hook plastic inserts (Fig.A, B), using the yellow marker line as a guide for correct trimming.
3. For 2007 GMC Yukon 2500 models, trim the grille insert to allow clearance for the receivers.
4. Refer back to step 2 on the previous page to finish this installation.

