



BASEPLATE KIT INSTALLATION INSTRUCTIONS

KIT# 3123-5

02/27/08

KS

ROADMASTER, Inc. 6110 NE 127th Ave. Vancouver, WA 98682 1-800-669-9690 fax 360-735-9300 www.roadmasterinc.com

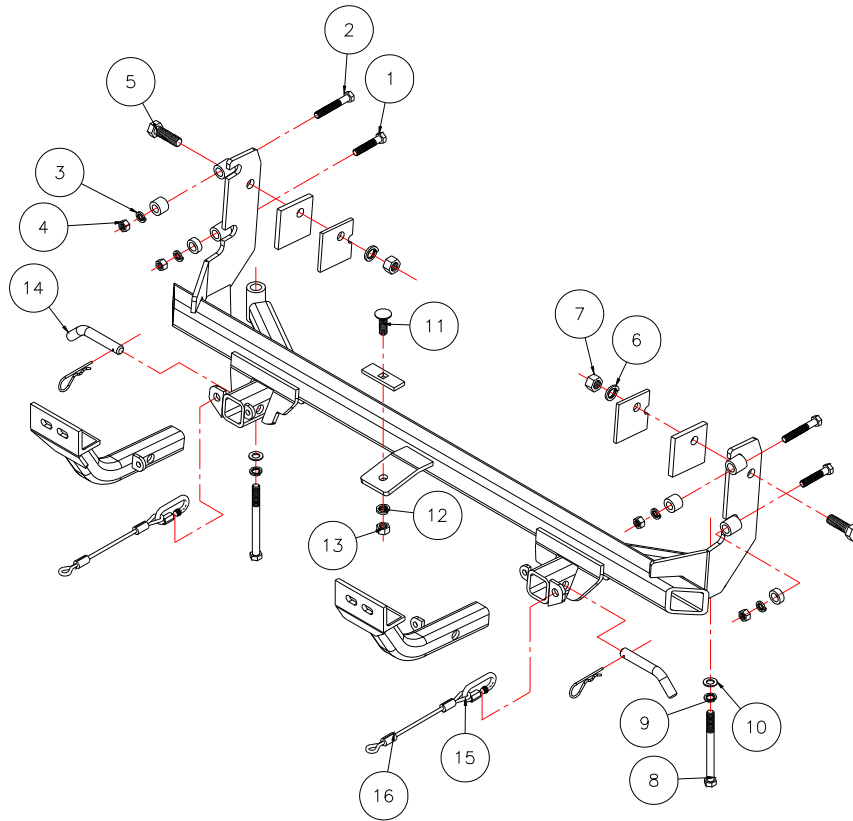

ITEM	QTY	Length	Width	HARDWARE	PART NO.
1	2	2 1/2"	7/16"	BOLTS	350078-00
2	2	3"	7/16"	BOLT	350080-00
3	4		7/16"	LOCK WASHER	350307-00
4	4		7/16"	NUT	350256-00
5	2	2"	5/8"	CAPSCREW	350150-00
6	2		5/8"	LOCK WASHER	350313-00
7	2		5/8"	NUT	350262-00
8	2	160mm	14mm	14mm X 2.0 X 160mm BOLT	355910-16
9	2		14mm	LOCK WASHER	355740-00
10	2		14mm	FENDER WASHER	355741-00
11	1	1 1/2"	1/2"	CARRIAGE BOLT	350362-00
12	1		1/2"	LOCK WASHER	350309-00
13	1		1/2"	NUT	350258-00
14	2			DRAW PIN/SPRING PIN	357035-00
15	2			CABLE CONNECTOR	200008-00
16	2	10"		SAFETY CABLES	500646-10



BASEPLATE KIT INSTALLATION INSTRUCTIONS

KIT# 3123-5

02/27/08

KS

ROADMASTER, Inc. 6110 NE 127th Ave. Vancouver, WA 98682 1-800-669-9690 fax 360-735-9300 www.roadmasterinc.com

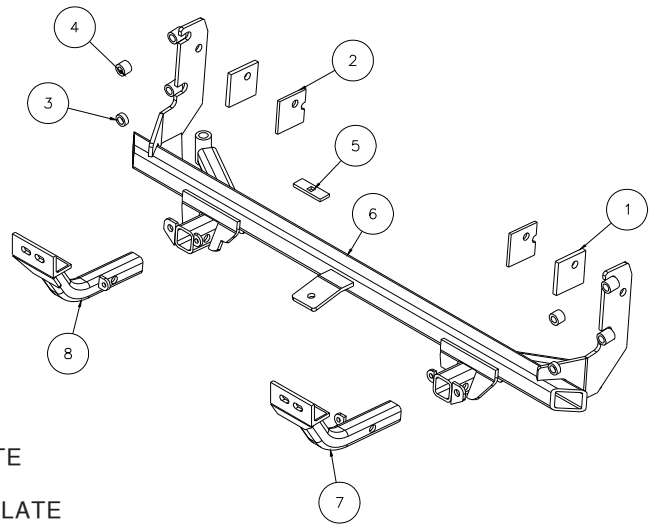

ITEM	QTY	PART NO.	ASSEMBLY
1	2	A-001482	3/8" x 3" x 3" BACKING PLATE
2	2	A-001481	1/4" x 2 1/2" x 3" BACKING PLATE
3	2	A-000187	1" O.D. x 3/8" x .219 WALL TUBE
4	2	A-000558	1" O.D. x 3/4" x .219 WALL TUBE

IMPORTANT: All baseplates *must* be assembled with all the bolts left loose for final adjustment and positioning (before tightening) unless otherwise instructed. All bolts *must* be torqued for proper strength. If more than one bolt is used per fastening point, the diagram may only show one. Use flat washers over all slotted holes and lock washers on all fasteners.

WARNING

Failure to heed these warnings or follow the installation instructions may result in a voided warranty, loss of towed vehicle, personal injury or death.

- Do not weld or modify this baseplate or its components. Welding or modification will void the warranty.
- Do not use this document as a basis to design/fabricate a baseplate, as it may not show all parts or structural components.
- We strongly recommend professional installation.
- If the towed vehicle has been in an accident, it must be properly repaired before attaching the baseplate. Do not install the baseplate if any structural frame damage is found.
- The installer must use all bolts and parts supplied. If running changes were made by the vehicle manufacturer after this kit was designed, some bolts or other fasteners may no longer be the correct size. It is the installer's responsibility to verify this kit is securely fastened to the vehicle.
- Use Loctite® Red on all bolts used to secure this baseplate. Torque all bolts to the specifications found at the end of these instructions. Do not over-torque the bolts or failure may occur.
- The installer must inspect the baseplate to ensure adequate clearance, particularly around hoses, air conditioner lines, radiators, etc. or non-warranty failure may result.
- Roadmaster manufactures many styles of baseplates. If your baseplate has removable arms, they must be removed before driving the vehicle, unless the arms can be pinned or padlocked in place. If not secured, the arms could vibrate out.
- Some motorhome chassis have such a tight turning radius that you can damage your motorhome, towed vehicle, tow bar or baseplate while turning sharply. Before getting on the road, test your turning radius in an empty parking lot. Turning too sharply could

result in non-warranty damage to your towing system, motorhome and/or towed vehicle.

- Do not back up with the towed vehicle attached or non-warranty damage will occur to your towing system or vehicles.
- The safety cables must connect the towing vehicle to the towed vehicle frame to frame, with the cables crossed, with enough slack for sharp turns. See cable instructions for proper routing. Failure to do so will result in non-warranty damage and/or the loss of the towed vehicle.
- This kit is designed for use with ROADMASTER tow bars and ROADMASTER adapters only. Using this kit with other brands, without an approved ROADMASTER adapter, may result in non-warranty damage or injury.
- Receiver extensions and out-of-level towing situations of 3 inches or more. This can cause the system to swing much higher and lower, causing excessive strain on the tow bar, baseplate and frame. That can cause the towing system to fail, causing property damage, personal injury or even death. If you must use a receiver extension or drop hitch to tow, it will reduce your receiver's weight capacity by 1/3 to avoid damaging your system. Never use more than one extension and/or drop hitch, as this will void your warranty.
- Every 3,000 miles, the owner must inspect all mounting points for cracks or fatigue, and check the fasteners for proper torque, according to the bolt torque requirements chart on the last page of these instructions.
- The owner must follow the vehicle manufacturer's instructions to prepare the vehicle for towing. Failure to do so may cause severe damage to the vehicle.
- This baseplate is only warranted for the original installation. Installing a used baseplate on another vehicle is not recommended and will void the warranty.



BASEPLATE KIT INSTALLATION INSTRUCTIONS

KIT# 3123-5

02/27/08

KS

ROADMASTER, Inc. 6110 NE 127th Ave. Vancouver, WA 98682 1-800-669-9690 fax 360-735-9300 www.roadmasterinc.com

This is one of our XL bracket series, which allows the visible front portion of the brackets to be easily removed from the front of the vehicle (Fig.A). The bracket kit consists of a main receiver brace, front braces and a hardware pack. The rear receiver braces mount to the bottom and side of the frame and protrude through the lower grill below the bumper. The front braces insert into the rear braces and pinned in place. The lower grille has to be trimmed to fit around the braces as well as the radiator air deflectors. Before starting the installation, lay out the kit components as illustrated. This will give you a visual idea of how the components work and also confirm that everything is present and accounted for.



Fig.A



Fig.B



Fig.C



Fig.D

1. **Important:** please use all supplied bolts and parts and read all instructions carefully before beginning this installation. The majority of questions you may have can be answered within the text, and proper installation will ensure safe and secure travel. Now, begin the installation. Begin by removing four plastic fasteners in the top of the fascia between the headlights (Fig.B).

2. Remove five plastic fasteners in each fender well (Fig.C), then remove 15 more plastic fasteners on the bottom of the fascia and lower splash panel (Fig.D,E). Remove the lower splash panel (Fig.F).



Fig.E



Fig.F



Fig.G

3. Disconnect the marker light connections on each side (Fig.F).

4. Remove one bolt (10mm head) then loosen two nuts and 10mm at the fascia fender junction on each side (Fig.G), then pull forward and down to release the fascia on both sides from the retaining slots (Fig.H,I). Remove the fascia and set aside.



Fig.H



Fig.I



BASEPLATE KIT INSTALLATION INSTRUCTIONS

KIT# 3123-5

02/27/08

KS

ROADMASTER, Inc. 6110 NE 127th Ave. Vancouver, WA 98682 1-800-669-9690 fax 360-735-9300 www.roadmasterinc.com



Fig.J



Fig.K



Fig.L

5. Remove four bumper core mounting bolts (13mm head) (Fig.J) on each side, then remove the aluminum bumper core (Fig.K).

6. Remove two bumper core support bolts (15mm head) from the side of each bumper support (Fig.L,M).



Fig.M



Fig.N



Fig.O

7. Now enlarge the mounting holes in both the bumper core support and the frame with a 1/2" drill bit on both sides (Fig.N).

8. Now, go to the inside of the frame for each side and locate a remaining mounting stud with a 15mm nut and remove the nut (Fig.O).



Fig.P



Fig.Q



Fig.R

9. Remove the bumper core supports by pulling forward and out of the frames (Fig.P).

10. Insert a 1/2" x 1 3/4" carriage bolt and 1/4" x 1" x 3" backing plate into the center hole in the bottom of the radiator cross member as shown in (Fig.Q).

11. Take the one hole spacer plates and tape to the outside of each frame over the existing slotted hole in each frame as shown in Figure R, in preparation for mounting the main receiver brace.



BASEPLATE KIT INSTALLATION INSTRUCTIONS

KIT# 3123-5

02/27/08

KS

ROADMASTER, Inc. 6110 NE 127th Ave. Vancouver, WA 98682 1-800-669-9690 fax 360-735-9300 www.roadmasterinc.com



Fig.S



Fig.T

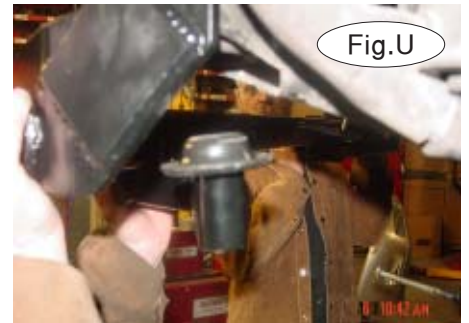

Fig.U

12. Support the subframe as shown (Fig.S) then remove the two front subframe mounting bolts (18mm head) (Fig.T).

13. Place the subframe suspension cups on the receiver brace as shown (Fig.U) then lift into position (Fig.V). Using a lock washer and nut, bolt in place with the center bolt to hold in position (Fig.W).



Fig.V



Fig.W



Fig.X

14. Bolt through the ends of the receiver brace and the subframe with two 14mm x 2.0 x 160mm bolts, lock washers and flat washers (Fig.X).



Fig.Y



Fig.Z



Fig.AA

15. Tighten the suspension bolts and the center bolt to align the main receiver brace (Fig.Y).

16. Now using the main brace as a drill template, drill a 5/8" hole in the side of each frame rail (Fig.Z).

17. Insert a notched backing into the front of each frame rail as shown (Fig.AA) and bolt through the brace on each side with a 5/8" x 2" bolt, lock washer and nut (Fig.BB). Torque these bolts to the specifications at the end of these instructions.



BASEPLATE KIT INSTALLATION INSTRUCTIONS

KIT# 3123-5

02/27/08

KS

ROADMASTER, Inc. 6110 NE 127th Ave. Vancouver, WA 98682 1-800-669-9690 fax 360-735-9300 www.roadmasterinc.com



Fig.BB



Fig.CC

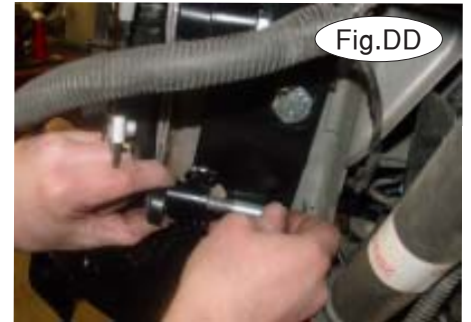

Fig.DD

18. Reinstall the front bumper core supports reversing steps 8 and 9 then bolt through the sides of the supports and the main receiver brace on each side with a 7/16" x 3" bolt, 3/4" spacer, lockwasher and nut in the top hole (Fig.CC) and a 7/16" x 2 1/2" bolt, 3/8" spacer, lock washer and nut in the bottom holes (Fig.DD,EE).



Fig.EE



Fig.FF



Fig.GG

- 19. Reinstall the bumper core reversing step 6 (Fig.J,K).
- 20. Torque all mounting bolts to the torque specifications below.
- 21. Reinstall the fascia reversing steps 1 through 4 with the exception of the lower splash panel (Fig.F). If the splash panel is to be reinstalled, mark areas to trim (Fig.FF) then cut to fit.
- 22. Insert the front braces into the receivers and secure with 5/8" draw pin and 3/16" spring pins (Fig.GG).
- 23. Mount the tow bar according to the tow bar manufacturer's instructions. Install the 10" safety cables on the main receiver cross bar with the provided quick links (Fig.GG). Attach the other end to the tow vehicle's safety cables and the tow bar.

BOLT TORQUE REQUIREMENTS

Note: The torque values represented below are intended as general guidelines. Torque requirements for specific applications may vary. Roadmaster does not warrant this information to be accurate for all applications and disclaims all liability for any claims or damages which may result from its use.

STANDARD BOLTS

Thread Size	Grade	Torque
5/16	5	13 ft./lb.
3/8	5	23 ft./lb.
7/16	5	37 ft./lb.
1/2	5	56 ft./lb.
5/8	5	150 ft./lb.

METRIC BOLTS

Thread Size	Grade	Plated / Unplated
8mm-1.0	8.8	20 ft./lb. 18 ft./lb.
8mm-1.25	8.8	19 ft./lb. 18 ft./lb.
10mm-1.25	8.8	38 ft./lb. 36 ft./lb.
10mm-1.5	8.8	37 ft./lb. 35 ft./lb.

METRIC BOLTS

Thread Size	Grade	Plated / Unplated
12mm-1.25	8.8	70 ft./lb. 65 ft./lb.
12mm-1.5	8.8	66 ft./lb. 61 ft./lb.
12mm-1.75	8.8	65 ft./lb. 60 ft./lb.
14mm-2.0	8.8	104 ft./lb. 97 ft./lb.

All illustrations and specifications contained herein are based on the latest information available at the time of publication approval. ROADMASTER, INC. reserves the right to make changes at any time without notice in material, specification and models or to discontinue models.