



# BASEPLATE KIT INSTALLATION INSTRUCTIONS

**KIT# 342-1**

03/20/12  
KS

ROADMASTER, Inc. 6110 NE 127th Ave. Vancouver, WA 98682 360-896-0407 fax 360-735-9300 www.roadmasterinc.com

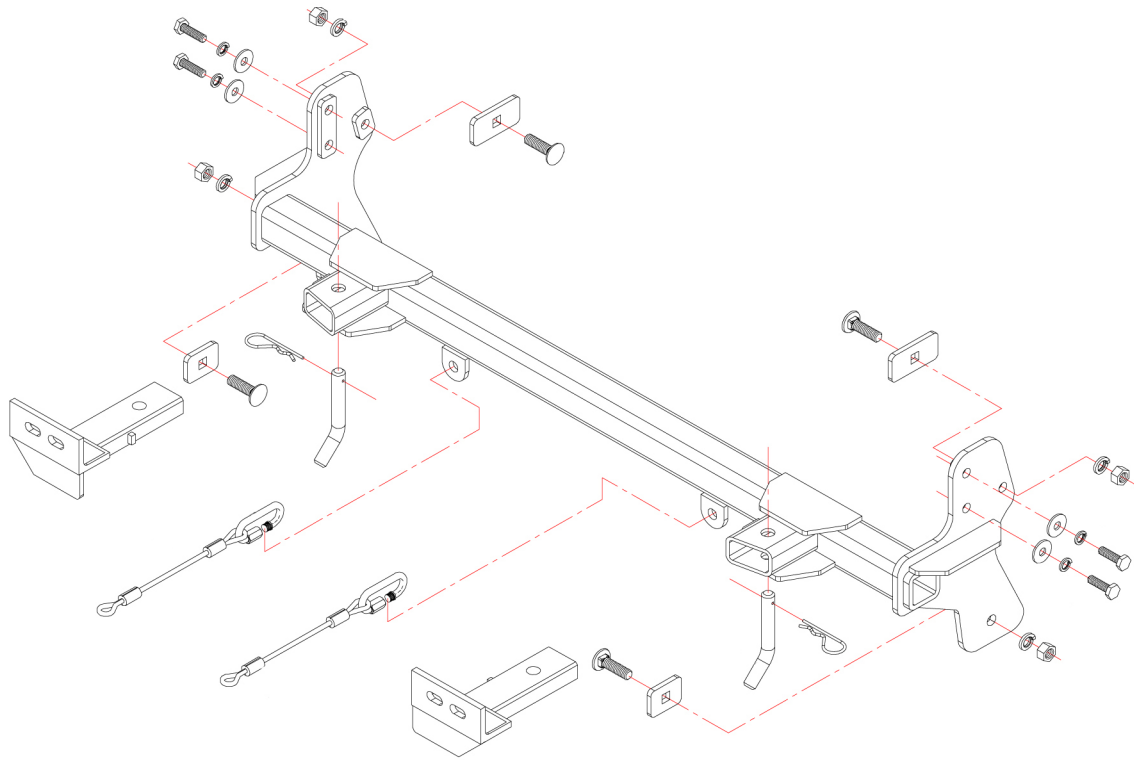

Item	Qty	Length	Width	Hardware	Part No.
1	4	1 3/4"	1/2"	CARRIAGE BOLT	350363-00
2	4		1/2"	LOCK WASHER	350309-00
3	4		1/2"	NUT	350258-00
4	4	35mm	10mm	10mm x 1.25 x 35mm BOLT	356202-00
5	4		10mm	LOCK WASHER	355715-00
6	4		10mm	FENDER WASHER	355716-00
7	2			DRAW PIN/SPRING PIN-LARGE BEND	357035-00
8	2			CABLE CONNECTOR	200008-00
9	2	15"		15" CABLE	500646-15



# BASEPLATE KIT INSTALLATION INSTRUCTIONS

**KIT# 342-1**

03/20/12  
KS

ROADMASTER, Inc. 6110 NE 127th Ave. Vancouver, WA 98682 360-896-0407 fax 360-735-9300 www.roadmasterinc.com

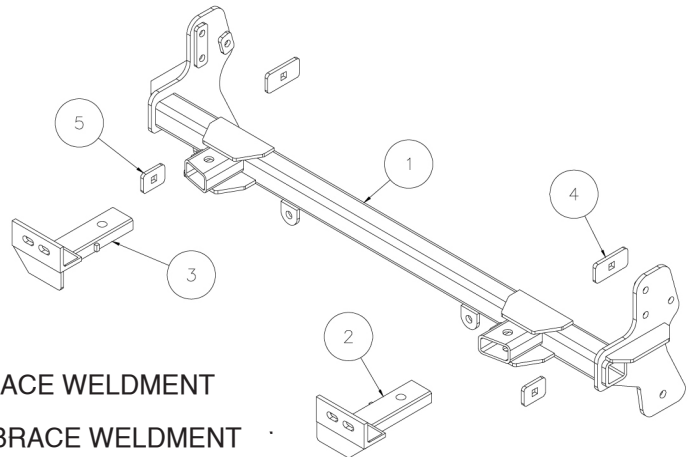

Item	Qty	Name	Assembly
1	1	C-000910	MAIN RECEIVER BRACE WELDMENT
2	1	C-000911	DRIVER SIDE ARM BRACE WELDMENT
3	1	C-000912	PASSENGER SIDE ARM BRACE WELDMENT
4	2	A-000479	1/4" x 1 1/2" x 3" SQ. HOLE BACKING PLATE
5	2	A-000039	1/4" x 1 1/2" x 2" SQ. HOLE BACKING PLATE

**IMPORTANT:** All baseplates **must** be assembled with all the bolts left loose for final adjustment and positioning (before tightening) unless otherwise instructed. All bolts **must** be torqued for proper strength. If more than one bolt is used per fastening point, the diagram may only show one.

- Use flat washers over all slotted holes
- Use lock washers on all fasteners

## WARNING

Failure to follow the below warnings and the installation instructions may result in voiding your warranty, property damage, the loss of your towed vehicle, personal injury or even death.

- Installation of most baseplates requires moderate mechanical aptitude and skills. We strongly recommend professional installation by an experienced installer.
- The installer must read the instructions and use all bolts and parts supplied.
- Use Loctite® Red on all bolts used for mounting this baseplate.
- Every 3,000 miles, the owner must inspect the fasteners for proper torque, according to the bolt torque requirements chart on the last page of these instructions. The owner must also inspect all mounting points for cracks or other signs of fatigue every 3,000 miles.
- The owner must check the vehicle manufacturer's instructions for the proper procedure(s) to prepare the vehicle for towing. Some vehicles must be equipped with a transmission lube pump, an axle disconnect, driveline disconnect or free-wheeling hubs before they can be towed. Failure to properly equip the vehicle will cause severe damage to the transmission.
- Do not weld. This baseplate is designed to be bolted to the vehicle. Welding will void the warranty.
- Do not use this document for custom fabrication, as it may not show all parts or structural components could result in loss of the towed vehicle.
- If the towed vehicle has been in an accident, it must be properly repaired before attaching the baseplate. Do not install the baseplate if any structural frame damage is found.
- If running changes were made by the vehicle manufacturer after this kit was designed, some bolts or other fasteners in the hardware pack may no longer be the correct size. It is the installer's responsibility to verify this kit is securely fastened to the vehicle and fitted with the correct hardware to account for these changes.
- Roadmaster manufactures many styles of baseplates. If your baseplate has removable arms, they must be removed before driving the vehicle, unless the arms can be pinned or padlocked in place. If not secured, the arms could vibrate out.
- Some motorhome chassis have such a tight turning radius that you can damage your motorhome, towed vehicle, tow bar or baseplate while turning sharply. Before getting on the road, test your turning radius in an empty parking lot. Turning too sharply could result in non-warranty damage to towing system, motorhome and/or towed vehicle.
- Do not back up with the towed vehicle attached or non-warranty damage will occur to your towing system, motorhome and/or towed vehicle.
- The safety cables must connect the towing vehicle to the towed vehicle frame to frame, with the cables crossed, with enough slack for sharp turns. Refer to the cable instructions for proper routing. Failure to leave enough slack in the safety cables, or failure to connect the safety cables frame to frame, will result in the loss of the towed vehicle.
- This kit is designed for use with ROADMASTER tow bars and ROADMASTER adapters only. Using this kit with other brands, without an approved ROADMASTER adapter, may result in non-warranty damage or injury.
- Upon final installation, the installer must inspect the baseplate to ensure adequate clearance, particularly around hoses, air conditioner lines, radiators, etc.
- This baseplate is only warranted for the original installation. Installing a used baseplate on another vehicle is not recommended and will void the warranty.



# BASEPLATE KIT INSTALLATION INSTRUCTIONS

**KIT# 342-1**

03/20/12  
KS

ROADMASTER, Inc. 6110 NE 127th Ave. Vancouver, WA 98682 360-896-0407 fax 360-735-9300 www.roadmasterinc.com

1. **Important:** please use all supplied bolts and parts and read all instructions carefully before beginning this installation. The majority of questions you may have can be answered within the text, and proper installation will ensure safe and secure travel. Now, begin the installation. This bracket kit is one of our XL series with removable front braces. The kit consists of a receiver brace which mounts to the side of the front frame tubes, two removable front braces and a hardware packet. Everything but the front arm braces install behind the bumper fascia (Fig. A). The front fascia and grille will have to be removed for the installation.



2. Starting on the top of the grille, remove four plastic fasteners (Fig.B) then pull forward on the top of the grille (Fig.C) to access four lower retainers (Fig.D,E).

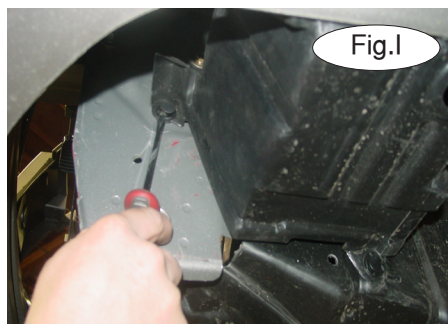
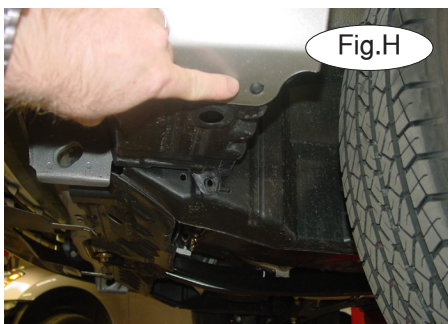
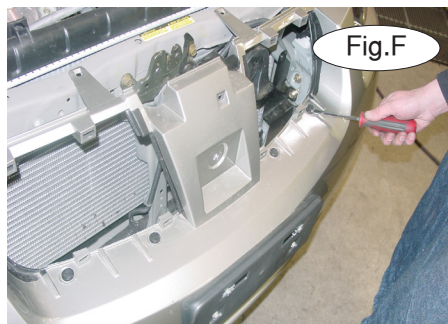
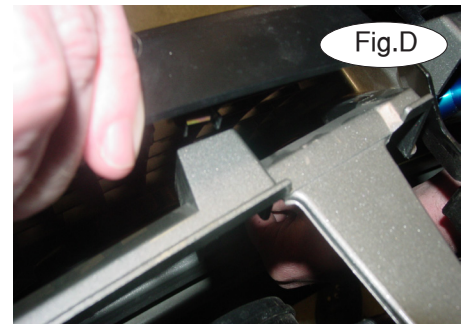
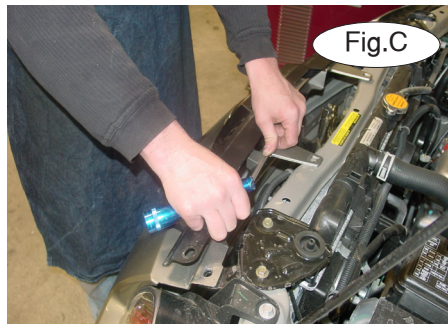
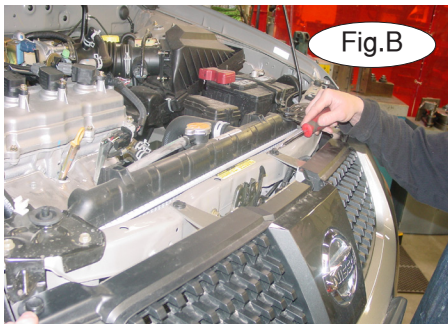

3. Remove four plastic fasteners in the top of the bumper fascia (Fig.F).
4. Move under the front fascia and remove two 10mm (head) center bolts (Fig.G) and two Phillips screws from each corner of the fascia (Fig.H).
5. Remove two plastic fasteners from the splash panels on each side (Fig.I) then pull back to access the fascia fender junction (Fig.J) and remove the fender fascia Phillips screws (Fig.K).



# BASEPLATE KIT INSTALLATION INSTRUCTIONS

**KIT# 342-1**

03/20/12  
KS

ROADMASTER, Inc. 6110 NE 127th Ave. Vancouver, WA 98682 360-896-0407 fax 360-735-9300 www.roadmasterinc.com



Fig.K



Fig.L

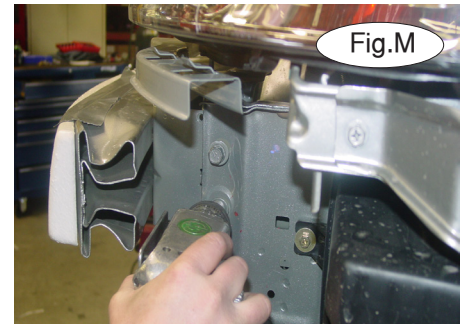

Fig.M

6. Pull the ends of the fascia out slightly on each side and pull forward to remove (Fig.L).

7. Move to the ends of the bumper core and remove two 14mm (head) bolts on each side (Fig.M).

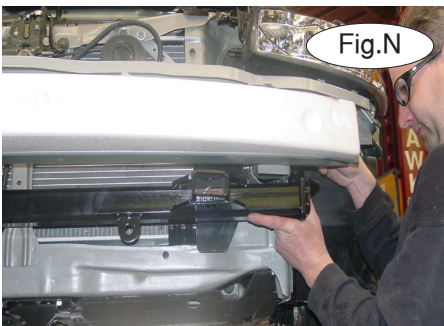

Fig.N

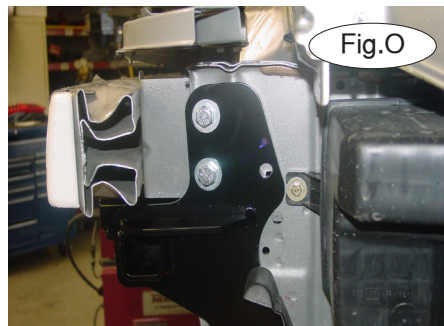

Fig.O



Fig.P

8. Hold the main receiver brace in position over the bolt holes on each side and bolt through the mounting holes with the bolts removed in step 7 (Fig.N). Align the brace, then tighten to hold in position (Fig.O).

9. Now, take a 1/2" x 2" carriage bolts, 1 1/2" x 2" backing plates, lock washers and nuts and bolt through the lower mounting holes and the tie down plates on each side (Fig.P). Tighten these bolts also (Fig.Q).

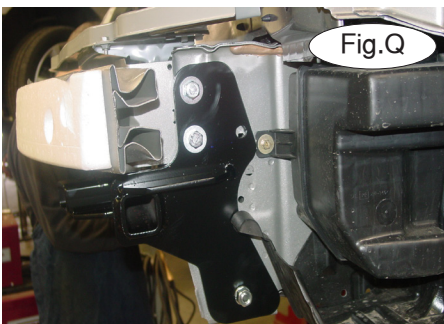

Fig.Q

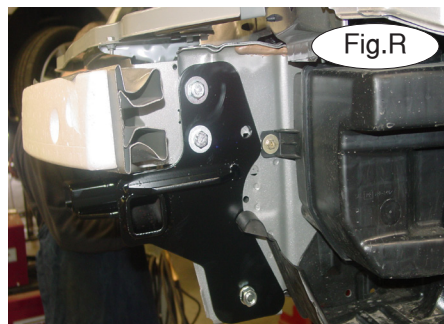

Fig.R

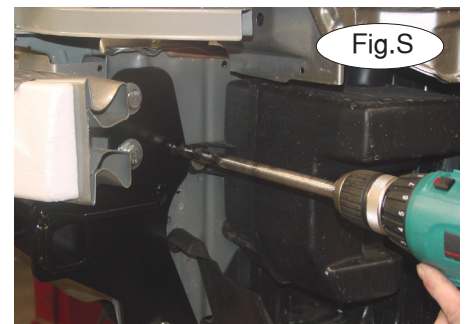

Fig.S

10. Using the receiver brace as a template, drill through the upper rear mounting hole as shown on each side (Fig.R).

11. Make sure the lower mounting bolts through the tie down plates are tight (Fig.S), then remove the two mounting bolts installed in step 8 on each side (Fig.T).

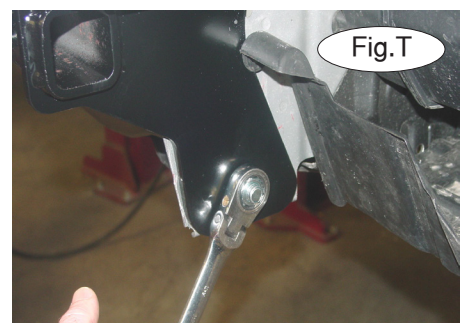

Fig.T



# BASEPLATE KIT INSTALLATION INSTRUCTIONS

**KIT# 342-1**

03/20/12  
KS

ROADMASTER, Inc. 6110 NE 127th Ave. Vancouver, WA 98682 360-896-0407 fax 360-735-9300 www.roadmasterinc.com

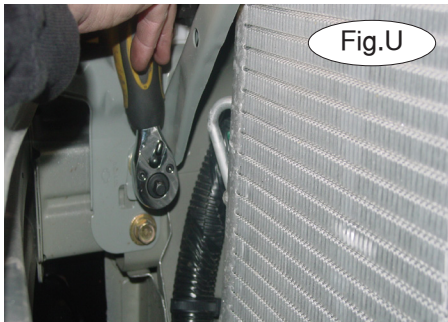

Fig.U

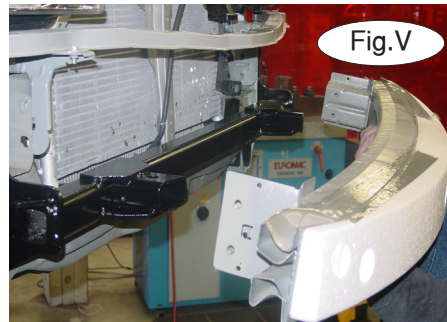

Fig.V

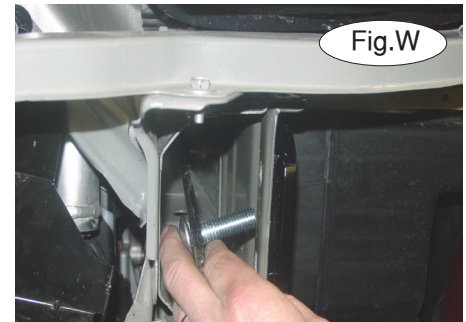

Fig.W

12. Remove the remaining 14mm (head) inner mounting bolts (Fig.U) holding the bumper core then remove the bumper core (Fig.V).

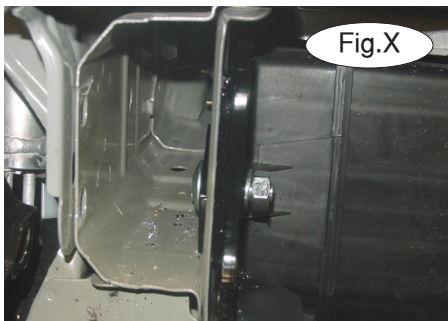

Fig.X

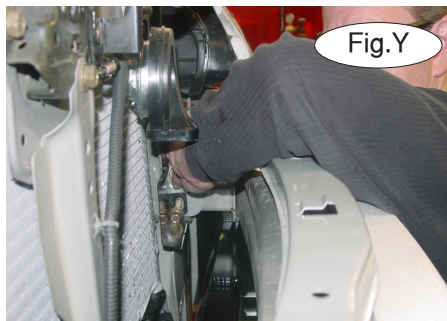

Fig.Y

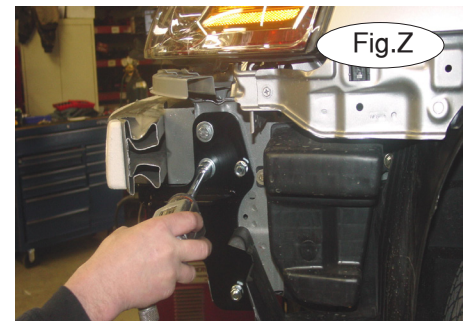

Fig.Z

13. Once the frame openings are exposed, insert  $\frac{1}{2}$ " x  $1\frac{3}{4}$ " carriage bolts and  $1\frac{1}{4}$ " x 3" backing plates through the mounting holes drilled in step 10 (Fig.W). Finish with lock washers and nuts (Fig.X).



Fig.AA



Fig.BB



Fig.CC

14. Remount the bumper core then tighten all bolts to the torque specifications found at the end of this document (Fig.Y,Z).

15. Replace the fascia, reversing steps 2 through 6.

16. Install the front braces in the receiver tubes and secure in place with  $\frac{5}{8}$ " draw pins and  $\frac{3}{16}$ " spring pins (Fig.AA,BB,CC).

17. Attach the 8" safety cables to the receiver braces with the included cable connectors. Connect the other ends to the tow vehicle's safety cables and tow bar (Fig.DD).

18. Install the tow bar according to the manufacturer's instructions.



Fig.DD



# BASEPLATE KIT INSTALLATION INSTRUCTIONS

**KIT# 342-1**

03/20/12  
KS

ROADMASTER, Inc. 6110 NE 127th Ave. Vancouver, WA 98682 360-896-0407 fax 360-735-9300 www.roadmasterinc.com

## BOLT TORQUE REQUIREMENTS

Note: The torque values represented below are intended as general guidelines. Torque requirements for specific applications may vary. Roadmaster does not warrant this information to be accurate for all applications and disclaims all liability for any claims or damages which may result from its use.

### STANDARD BOLTS

Thread Size	Grade	Torque
5/16.....	5.....	13 ft./lb.
3/8.....	5.....	23 ft./lb.
7/16.....	5.....	37 ft./lb.
1/2.....	5.....	56 ft./lb.
5/8.....	5.....	150 ft./lb.

### METRIC BOLTS

Thread Size	Grade	Plated / Unplated
8mm-1.0 .....	8.8 .....	20 ft./lb. 18 ft./lb.
8mm-1.25 .....	8.8 .....	19 ft./lb. 18 ft./lb.
10mm-1.25 .....	8.8 .....	38 ft./lb. 36 ft./lb.
10mm-1.5 .....	8.8 .....	37 ft./lb. 35 ft./lb.

### METRIC BOLTS

Thread Size	Grade	Plated / Unplated
12mm-1.25 .....	8.8 .....	70 ft./lb. 65 ft./lb.
12mm-1.5 .....	8.8 .....	66 ft./lb. 61 ft./lb.
12mm-1.75 .....	8.8 .....	65 ft./lb. 60 ft./lb.
14mm-2.0 .....	8.8 .....	104 ft./lb. 97 ft./lb.

All illustrations and specifications contained herein are based on the latest information available at the time of publication approval. ROADMASTER, INC. reserves the right to make changes at any time without notice in material, specification and models or to discontinue models.