



BASEPLATE KIT INSTALLATION INSTRUCTIONS

ROADMASTER, Inc. 6110 NE 127th Ave. Vancouver, WA 98682 1-800-669-9690 fax 360-735-9300 www.roadmasterinc.com

PARTS LIST:

- 1- MAIN RECEIVER (A)
- 1- FRONT ARM (B) Passenger Side
- 1- FRONT ARM (C) Driver's Side

KIT NO. 468-9

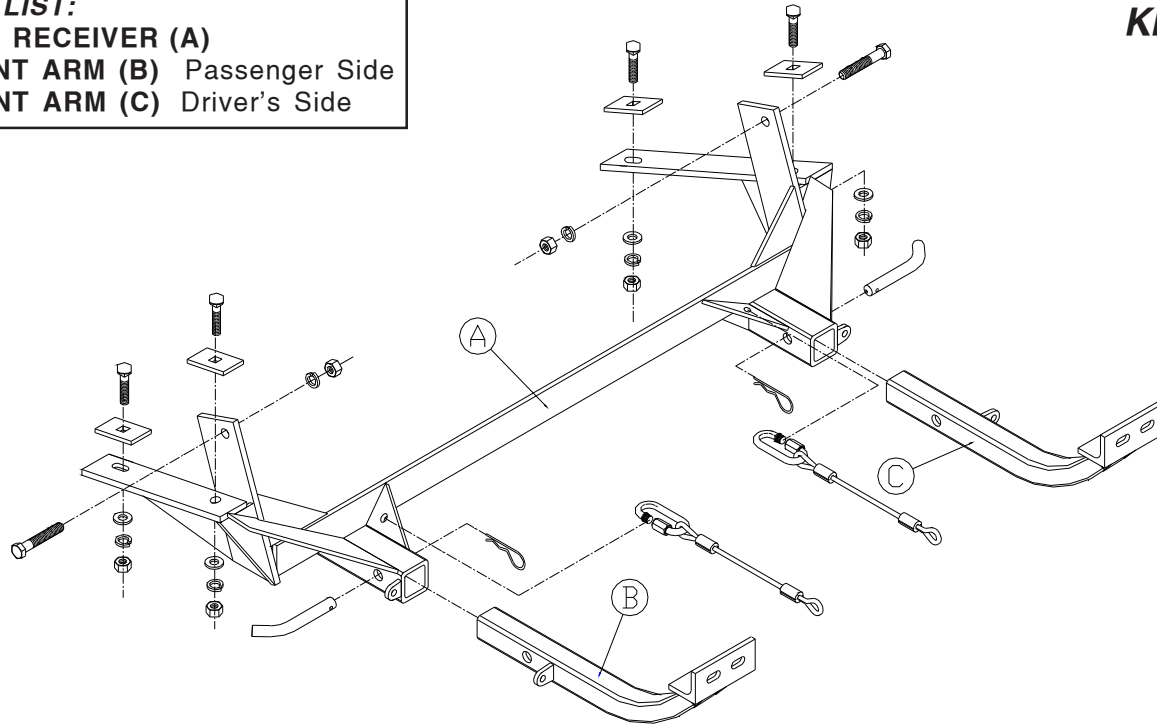

3/28/02

IMPORTANT: All brackets **must** be assembled with all the bolts left loose for final adjustment and positioning (before tightening) unless otherwise instructed. All bolts **must** be torqued for proper strength. If more than one bolt is used per fastening point, the diagram may only show one.

- Use flat washers over all slotted holes
- Use lock washers on all fasteners

WARNING

Failure to follow these instructions can result in property damage, personal injury or even death.

- Installation of most mounting brackets requires moderate mechanical aptitude and skills. We strongly recommend professional installation by an experienced installer.
- The installer must read the instructions and use all bolts and parts supplied. Failure to do so could result in loss of the towed vehicle.
- Use Loctite® Red on all bolts used for mounting this bracket.
- Do not use this document for custom fabrication, as it may not show all parts or structural components. Custom fabrication or an attempt to copy this bracket design could result in loss of the towed vehicle.
- Every 3,000 miles, the owner must inspect the fasteners for proper torque, according to the bolt torque requirements chart on the last page of these instructions. The owner must also inspect all mounts and brackets for cracks or other signs of fatigue every 3,000 miles. Failure to do so could result in loss of the towed vehicle.
- The owner must check the vehicle manufacturer's instructions for the proper procedure(s) to prepare the vehicle for towing. Some vehicles must be equipped with a transmission lube pump, an axle disconnect, driveline disconnect or free-wheeling hubs before they can be towed. Failure to properly equip the vehicle will cause severe damage to the transmission.
- If running changes were made by the vehicle manufacturer after this bracket was designed, some bolts or other fasteners in the hardware pack may no longer be the correct size. It is the installer's responsibility to verify that the bracket is securely fastened to the vehicle and fitted with the correct hardware to account for these changes. Failure to securely

fasten the bracket could result in loss of the towed vehicle.

- If the towed vehicle has been in an accident, it must be properly repaired before attaching the bracket. Do not install the bracket if any structural frame damage is found. Failure to repair the damage could result in the loss of the towed vehicle.
- Some motorhome chassis have such a tight turning radius that you can damage your motorhome, towed vehicle, tow bar or bracket while turning sharply. Before getting on the road, test your turning radius in an empty parking lot. Turning too sharply could result in non-warranty damage to towing system, motorhome and/or towed vehicle.
- Do not back up with the towed vehicle attached or non-warranty damage will occur to your towing system, motorhome and/or towed vehicle.
- The safety cables must connect the towing vehicle to the towed vehicle frame to frame, with the cables crossed, with enough slack for sharp turns. Refer to the cable instructions for proper routing. Failure to leave enough slack in the safety cables, or failure to connect the safety cables frame to frame, will result in the loss of the towed vehicle.
- This bracket is designed for use with ROADMASTER tow bars and ROADMASTER adaptors only. Using this bracket with other brands, without an approved ROADMASTER adaptor, may result in non-warranty damage or injury.
- Upon final installation, the installer must inspect the bracket to ensure adequate clearance, particularly around hoses, air conditioner lines, radiators, etc., or non-warranty damage to the towed vehicle will result.
- This bracket is only warranted for the original installation. Installing a used bracket on another vehicle is not recommended and will void the warranty.

BASEPLATE KIT INSTALLATION INSTRUCTIONS

ROADMASTER, Inc. 6110 NE 127th Ave. Vancouver, WA 98682 1-800-669-9690 fax 360-735-9300 www.roadmasterinc.com

KIT NO. 468-9

1. **Important:** please use all supplied bolts and parts and read all instructions carefully before beginning this installation. The majority of questions you may have can be answered within the text, and proper installation will ensure safe and secure travel. Now, begin the installation. This kit is one of our XL series which is partly removable. The bulk of the main receiver brace is hidden behind the plastic nose skin and lower grille. Start the installation by removing four 10mm fasteners from the bottom of the bumper skin. This will allow you to pull the lower bumper skin down to access the area in front of the radiator. Remove two plastic retainers per side on the back of the bumper, holding the plastic air flow diverting panels. Push these panels back out of the way.
2. Locate a existing hole in the bottom of each frame tube approximately 10" from the front of the frame. Fish wire a 1/2" x 2" clipped carriage bolt and 1/4" x 1 1/2" x 2 1/2" backing plate through a large side access hole in each frame tube into these existing bottom holes. *Note:* on later vehicles this hole may have to be drilled, in this case proceed to step 3, using a jack or similar lifting device to hold the main receiver brace in place.
3. Now locate a large bolt going through the frame and the end of the EA units on each side. Remove these bolts and substitute 1/2" x 3 1/2" bolts from the bolt kit. Push these bolts through from the outside of each frame tube through the EA units and into the inner wall of frame until flush with the inner wall. The main receiver brace will be installed between the frame tubes on these bolts.
4. Take the main receiver brace and install between the frame tubes against the bottom of the frame. Push the 3 1/2" bolts through the main brace and bolt both these bolts and the bottom bolts installed in step 2 using 1/2" lock washers and nuts.
5. Drill two holes in the bottom of each frame rail using the main receiver brace as a drill template. Fish wire a 1/2" x 2" clipped carriage bolt and 1/4" x 1 1/2" x 2 1/2" backing plate though a large side access hole in each frame tube into these drilled holes.
6. Tighten these bolts to the torque specifications below.
7. Reinstall the plastic air panels and retainers, trimming to fit if necessary, replace the bumper skin retainers removed in step 1.
8. Insert the front braces into the receivers and pin using 5/8" receiver pins and 1/8" spring pins.
9. Install the tow bar according to the manufacturers's instructions then torque all bolts to the specifications below.
10. Attach one end of the 15" safety cables to the receivers with the provided cable connectors, attach the other end to the tow bar and the tow vehicle's safety cables.

Hardware

3/28/02

- | | |
|--|----------------------|
| 2- 1/2" x 3-1/2" bolt | 2- 5/8" draw pins |
| 4- 1/2" x 2" clipped carriage bolts | 2- 1/8" spring pins |
| 6- 1/2" nuts | 2- 15" safety cables |
| 6- 1/2" lock washers | 2- cable connectors |
| 4- 1/2" flat washers | |
| 4- 1/4" x 1-1/2" x 2-1/2" sq. hole backing plate | |

BOLT TORQUE REQUIREMENTS

Note: The torque values represented below are intended as general guidelines. Torque requirements for specific applications may vary. Roadmaster does not warrant this information to be accurate for all applications and disclaims all liability for any claims or damages which may result from its use.

| STANDARD BOLTS | | | METRIC BOLTS | | | METRIC BOLTS | | |
|----------------|-------|-------------|--------------|-------|-----------------------|--------------|-------|------------------------|
| Thread Size | Grade | Torque | Thread Size | Grade | Plated/Unplated | Thread Size | Grade | Plated/Unplated |
| 5/16 | 5 | 13 ft./lb. | 8mm-1.0 | 8.8 | 20 ft./lb. 18 ft./lb. | 12mm-1.25 | 8.8 | 70 ft./lb. 65 ft./lb. |
| 3/8 | 5 | 23 ft./lb. | 8mm-1.25 | 8.8 | 19 ft./lb. 18 ft./lb. | 12mm-1.5 | 8.8 | 66 ft./lb. 61 ft./lb. |
| 7/16 | 5 | 37 ft./lb. | 10mm-1.25 | 8.8 | 38 ft./lb. 36 ft./lb. | 12mm-1.75 | 8.8 | 65 ft./lb. 60 ft./lb. |
| 1/2 | 5 | 56 ft./lb. | 10mm-1.5 | 8.8 | 37 ft./lb. 35 ft./lb. | 14mm-2.0 | 8.8 | 104 ft./lb. 97 ft./lb. |
| 5/8 | 5 | 150 ft./lb. | | | | | | |