



# BASEPLATE KIT INSTALLATION INSTRUCTIONS

**KIT# 497-1**

03/10/08

KS

ROADMASTER, Inc. 6110 NE 127th Ave. Vancouver, WA 98682 1-800-669-9690 fax 360-735-9300 www.roadmasterinc.com

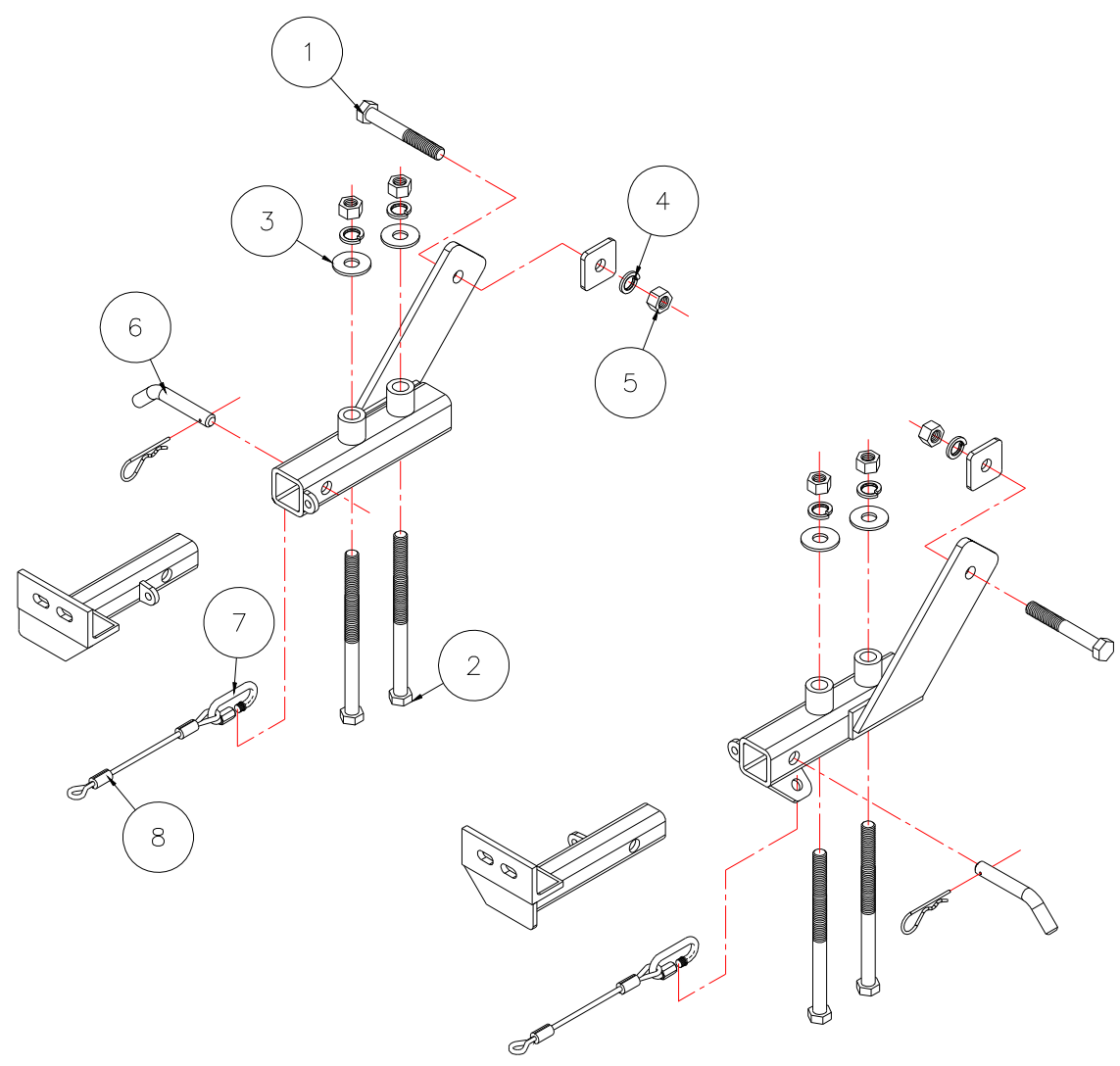

ITEM	QTY	Length	Width	HARDWARE	PART NO.
1	2	4"	5/8"	BOLT	350158-00
2	4	9"	5/8"	BOLT	350379-00
3	4	5/8"		FLAT WASHER	350348-00
4	6	5/8"		LOCK WASHER	350313-00
5	6	5/8"		NUT	350262-00
6	2			DRAW PIN/SPRING PIN	357035-00
7	2			CABLE CONNECTORS	200008-00
8	2	8"		8" SAFETY CABLES, 8,000 lb. rated	650648-08



# BASEPLATE KIT INSTALLATION INSTRUCTIONS

**KIT# 497-1**

03/10/08

KS

ROADMASTER, Inc. 6110 NE 127th Ave. Vancouver, WA 98682 1-800-669-9690 fax 360-735-9300 www.roadmasterinc.com

**IMPORTANT:** All brackets **must** be assembled with all the bolts left loose for final adjustment & positioning (before tightening) unless otherwise instructed. All bolts **must** be torqued for proper strength. If more than one bolt is used per fastening point, the diagram may only show one.

- Use flat washers over all slotted holes
- Use lock washers on all fasteners

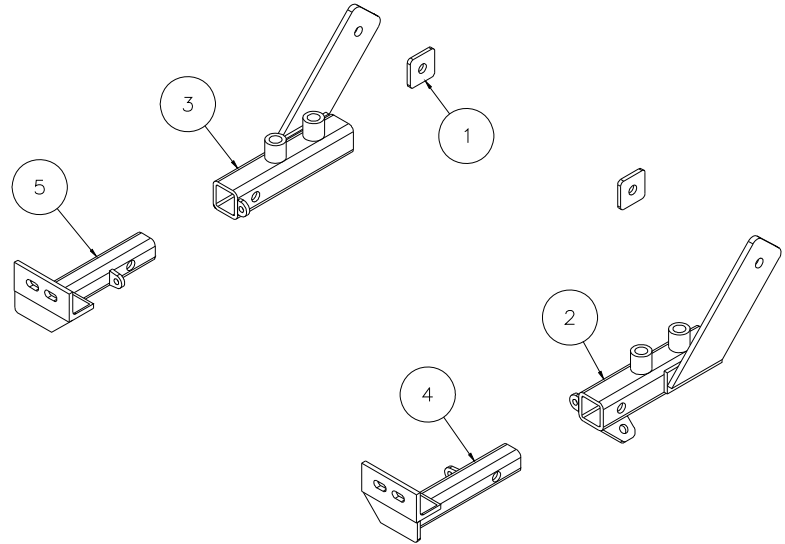

ITEM	QTY	PART NO.	ASSEMBLY
1	2	A-000188	1/4" X 2" X 2" BACKING PLATE
2	1	C-000871	DRIVER SIDE RECEIVER BRACE WELDMENT
3	1	C-000872	PASSENGER SIDE RECEIVER BRACE WELDMENT
4	1	C-000873	DRIVER SIDE ARM BRACE WELDMENT
5	1	C-000874	PASSENGER SIDE ARM BRACE WELDMENT

## WARNING

Failure to follow these instructions can result in property damage, personal injury or even death.

- Installation of most mounting brackets requires moderate mechanical aptitude and skills. We strongly recommend professional installation by an experienced installer.
- The installer must read the instructions and use all bolts and parts supplied. When the instructions require the reuse of factory bolts, thread lock and/or lock washers must also be used. Failure to securely fasten the bracket could result in loss of the towed vehicle.
- Do not use this document for custom fabrication, as it may not show all parts or structural components. Custom fabrication or an attempt to copy this bracket design could result in loss of the towed vehicle.
- Every 3,000 miles, the owner must inspect the fasteners for proper torque, according to the bolt torque requirements chart on the last page of these instructions. The owner must also inspect all mounts and brackets for cracks or other signs of fatigue every 3,000 miles. Failure to do so could result in loss of the towed vehicle.
- The owner must check the vehicle manufacturer's instructions for the proper procedure(s) to prepare the vehicle for towing. Some vehicles must be equipped with a transmission lube pump, an axle disconnect, driveline disconnect or free-wheeling hubs before they can be towed. Failure to properly equip the vehicle will cause severe damage to the transmission.
- If running changes were made by the vehicle manufacturer after this bracket was designed, some bolts or other fasteners in the hardware pack may no longer be the correct size. It is the installer's responsibility to verify that the bracket is securely fastened to the vehicle and fitted with the correct hardware to account for these changes. Failure to

- securely fasten the bracket could result in loss of the towed vehicle.
- If the towed vehicle has been in an accident, it must be properly repaired before attaching the bracket. Do not install the bracket if any structural frame damage is found. Failure to repair the damage could result in the loss of the towed vehicle.
- Some motorhome chassis have such a tight turning radius that you can damage your motorhome, towed vehicle, tow bar or bracket while turning sharply. Before getting on the road, test your turning radius in an empty parking lot. Turning too sharply could result in non-warranty damage to towing system, motorhome and/or towed vehicle.
- Do not back up with the towed vehicle attached or non-warranty damage will occur to your towing system, motorhome and/or towed vehicle.
- The safety cables must connect the towing vehicle to the towed vehicle frame to frame, with the cables crossed, with enough slack for sharp turns. Refer to the cable instructions for proper routing. Failure to leave enough slack in the safety cables, or failure to connect the safety cables frame to frame, will result in the loss of the towed vehicle.
- This bracket is designed for use with ROADMASTER tow bars and ROADMASTER adaptors only. Using this bracket with other brands, without an approved ROADMASTER adaptor, may result in non-warranty damage or injury.
- Upon final installation, the installer must inspect the bracket to ensure adequate clearance, particularly around hoses, air conditioner lines, radiators, etc., or non-warranty damage to the towed vehicle will result.
- This bracket is only warranted for the original installation. Installing a used bracket on another vehicle is not recommended and will void the warranty.



# BASEPLATE KIT INSTALLATION INSTRUCTIONS

**KIT# 497-1**

03/10/08

KS

ROADMASTER, Inc. 6110 NE 127th Ave. Vancouver, WA 98682 1-800-669-9690 fax 360-735-9300 www.roadmasterinc.com

This bracket kit is one of our XL series, and is designed to attach directly to your factory tow loop mounting holes and the side of the frame. The kit consists of the main receiver braces, front braces and a hardware pack. The receiver brace mounts to the bottom of the frame rails on each side and extend forward through the factory tow loop area in the bumper fascia.

Start by laying the kit out according to the illustration. This will give you a visual idea of how the kit installs and also confirm that the kit components are present and accounted for.



1. **Important:** please use all supplied bolts and parts and read all instructions carefully before beginning this installation. The majority of questions you may have can be answered within the text, and proper installation will ensure safe and secure travel. Now, begin the installation. Start by removing the lower air dam (11 plastic fasteners) (Fig.B,C). *Note:* the lower air dam can be left off or trimmed to fit and reinstalled after the last step.

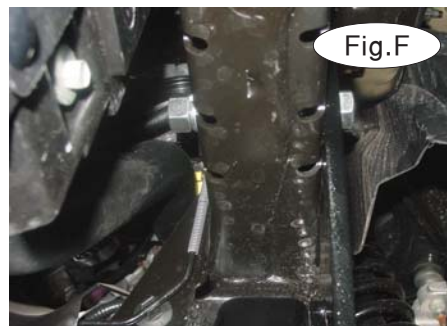
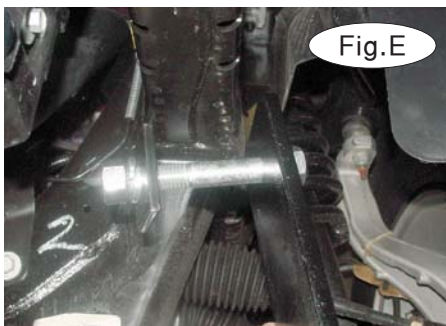

2. Look under the frame rails on each side and locate two elongated holes. Using these holes as a drill guide, drill two 5/8" holes through the top of each frame rail (Fig.D).

3. Working on one side at a time, take a receiver brace and hold it under the frame over the slotted holes with the rear side mount over a existing frame hole.

Bolt through the rear most mounting hole and the frame with a 5/8" x 4" bolt, 2" x 2" backing plate, lock washer and nut (Fig.E,F).

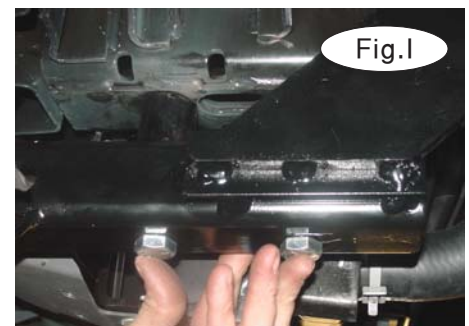



# BASEPLATE KIT INSTALLATION INSTRUCTIONS

**KIT# 497-1**

03/10/08

KS

ROADMASTER, Inc. 6110 NE 127th Ave. Vancouver, WA 98682 1-800-669-9690 fax 360-735-9300 www.roadmasterinc.com

4. Now bolt through the bottom of the receiver brace and the frame with a two 5/8" x 9" bolts (Fig.G), using 5/8" flat washers, lock washers and nuts on the top of the frame (Fig.H,I).

5. Repeat steps 3 through 6 for the remaining side.

6. Torque all bolts to the specifications below.

7. Insert the front braces into the receiver braces and secure in place with 5/8" draw pins and 1/8" spring pins (Fig.J).

8. Install the tow bar according to the manufacturer's instructions and torque all mounting bolts to the specifications below.

9. Attach one end of the safety cables to the lower front hole with the included cable connectors (Fig.K) and the other end to the tow vehicles safety cables and the tow bar.



## BOLT TORQUE REQUIREMENTS

Note: The torque values represented below are intended as general guidelines. Torque requirements for specific applications may vary. Roadmaster does not warrant this information to be accurate for all applications and disclaims all liability for any claims or damages which may result from its use.

### STANDARD BOLTS

Thread Size	Grade	Torque
5/16	5	13 ft./lb.
3/8	5	23 ft./lb.
7/16	5	37 ft./lb.
1/2	5	56 ft./lb.
5/8	5	150 ft./lb.

### METRIC BOLTS

Thread Size	Grade	Plated / Unplated
8mm-1.0	8.8	20 ft./lb. 18 ft./lb.
8mm-1.25	8.8	19 ft./lb. 18 ft./lb.
10mm-1.25	8.8	38 ft./lb. 36 ft./lb.
10mm-1.5	8.8	37 ft./lb. 35 ft./lb.

### METRIC BOLTS

Thread Size	Grade	Plated / Unplated
12mm-1.25	8.8	70 ft./lb. 65 ft./lb.
12mm-1.5	8.8	66 ft./lb. 61 ft./lb.
12mm-1.75	8.8	65 ft./lb. 60 ft./lb.
14mm-2.0	8.8	104 ft./lb. 97 ft./lb.

All illustrations and specifications contained herein are based on the latest information available at the time of publication approval. ROADMASTER, INC. reserves the right to make changes at any time without notice in material, specification and models or to discontinue models.