

BASEPLATE KIT INSTALLATION INSTRUCTIONS

ROADMASTER, Inc. 6110 NE 127th Ave. Vancouver, WA 98682 1-800-669-9690 fax 360-735-9300 www.roadmasterinc.com

PARTS LIST:

- 1- FRONT BRACE (A) - Passenger side
- 1- FRONT BRACE (B) - Driver's side
- 1- MAIN BRACE (C) - Passenger side
- 1- MAIN BRACE (D) - Driver's side

KIT NO. 510-3

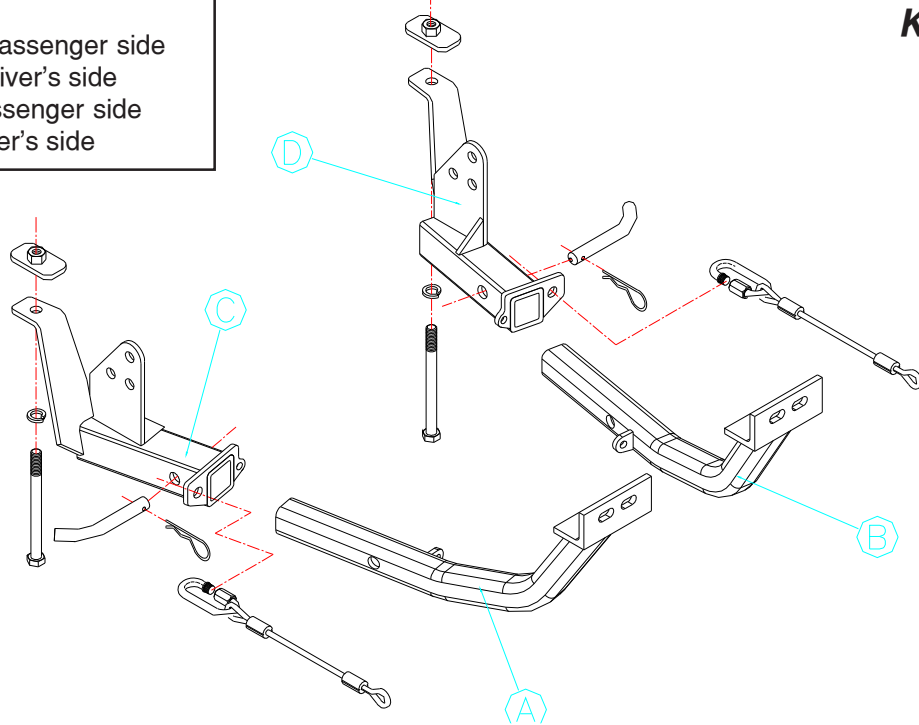

9-22-00

IMPORTANT: All baseplates **must** be assembled with all the bolts left loose for final adjustment and positioning (before tightening) unless otherwise instructed. All bolts **must** be torqued for proper strength. If more than one bolt is used per fastening point, the diagram may only show one.

- Use flat washers over all slotted holes
- Use lock washers on all fasteners

WARNING

Failure to follow the below warnings and the installation instructions may result in voiding your warranty, property damage, the loss of your towed vehicle, personal injury or even death.

- Installation of most baseplates requires moderate mechanical aptitude and skills. We strongly recommend professional installation by an experienced installer.
- The installer must read the instructions and use all bolts and parts supplied.
- Use Loctite® Red on all bolts used for mounting this baseplate.
- Every 3,000 miles, the owner must inspect the fasteners for proper torque, according to the bolt torque requirements chart on the last page of these instructions. The owner must also inspect all mounting points for cracks or other signs of fatigue every 3,000 miles.
- The owner must check the vehicle manufacturer's instructions for the proper procedure(s) to prepare the vehicle for towing. Some vehicles must be equipped with a transmission lube pump, an axle disconnect, driveline disconnect or free-wheeling hubs before they can be towed. Failure to properly equip the vehicle will cause severe damage to the transmission.
- Do not weld. This baseplate is designed to be bolted to the vehicle. Welding will void the warranty.
- Do not use this document for custom fabrication, as it may not show all parts or structural components could result in loss of the towed vehicle.
- If the towed vehicle has been in an accident, it must be properly repaired before attaching the baseplate. Do not install the baseplate if any structural frame damage is found.
- If running changes were made by the vehicle manufacturer after this

kit was designed, some bolts or other fasteners in the hardware pack may no longer be the correct size. It is the installer's responsibility to verify this kit is securely fastened to the vehicle and fitted with the correct hardware to account for these changes.

- Roadmaster manufactures many styles of baseplates. If your baseplate has removable arms, they must be removed before driving the vehicle, unless the arms can be pinned or padlocked in place. If not secured, the arms could vibrate out.
- Some motorhome chassis have such a tight turning radius that you can damage your motorhome, towed vehicle, tow bar or baseplate while turning sharply. Before getting on the road, test your turning radius in an empty parking lot. Turning too sharply could result in non-warranty damage to towing system, motorhome and/or towed vehicle.
- Do not back up with the towed vehicle attached or non-warranty damage will occur to your towing system, motorhome and/or towed vehicle.
- The safety cables must connect the towing vehicle to the towed vehicle frame to frame, with the cables crossed, with enough slack for sharp turns. Refer to the cable instructions for proper routing. Failure to leave enough slack in the safety cables, or failure to connect the safety cables frame to frame, will result in the loss of the towed vehicle.
- This kit is designed for use with ROADMASTER tow bars and ROADMASTER adapters only. Using this kit with other brands, without an approved ROADMASTER adapter, may result in non-warranty damage or injury.
- Upon final installation, the installer must inspect the baseplate to ensure adequate clearance, particularly around hoses, air conditioner lines, radiators, etc.
- This baseplate is only warranted for the original installation. Installing a used baseplate on another vehicle is not recommended and will void the warranty.

BASEPLATE KIT INSTALLATION INSTRUCTIONS

ROADMASTER, Inc. 6110 NE 127th Ave. Vancouver, WA 98682 1-800-669-9690 fax 360-735-9300 www.roadmasterinc.com

KIT NO. 510-3

1. **Important:** please use all supplied bolts and parts and read all instructions carefully before beginning this installation. The majority of questions you may have can be answered within the text, and proper installation will ensure safe and secure travel. Now, begin the installation. This XL Series mounting kit uses the existing front tow plate mounts and frame as attachment points. Prepare the car for mounting the receiver braces by removing the lower splash panel. This is held on with three small bolts in front and plastic fasteners on the sides.
2. Remove the tow plates on each side and save the bolts to install the lower receiver braces. Work on one side of the car at a time. Save the tow plate bolts for the installation of the receiver braces.
3. Working on one side of the car, bolt through the lower receiver brace side plate using the three stock tow plate bolts.
4. The back of the brace should line up with a existing hole in the frame. Use this hole as a guide to drill a hole through the top of the frame using a 1/2" bit. *Note:* the air cleaner may have to be removed for better access to the top of the passenger side frame on some models.
5. Bolt through the frame with a 1/2" x 6" bolt, a 1/4" x 1 1/2" x 2 3/4" backing plate, lock washer and nut. Be sure to use the backing plate on the top of the frame.
6. Follow steps 2 and 3 to install the remaining receiver brace. Torque all bolts to the specifications below.
7. Insert the front braces into the lower receivers and secure using the supplied 5/8" draw pins and 1/8" spring pins.
8. Mount the tow bar according to the manufacturer's specifications.
9. Reinstall the lower splash panel then connect the 15" tow cables to the lower receiver braces using the supplied cable connectors. Connect the other end of the safety cables to the tow vehicle's safety cables.

HARDWARE LIST:

- 2-1/2" X 1 1/2" X 2 3/4" BACKING PLATES WITH NUTS
- 2-1/2" X 6" BOLTS
- 2-1/2" LOCK WASHERS
- 2-15" SAFETY CABLES
- 2-CABLE CONNECTORS
- 2-5/8" DRAW PINS
- 2-1/8" SPRING PINS

9-22-00

BOLT TORQUE REQUIREMENTS

Note: The torque values represented below are intended as general guidelines. Torque requirements for specific applications may vary. Roadmaster does not warrant this information to be accurate for all applications and disclaims all liability for any claims or damages which may result from its use.

STANDARD BOLTS			METRIC BOLTS			METRIC BOLTS		
Thread Size	Grade	Torque	Thread Size	Grade	Plated/Unplated	Thread Size	Grade	Plated/Unplated
5/16	5	13 ft./lb.	8mm-1.0	8.8	20 ft./lb. 18 ft./lb.	12mm-1.25	8.8	70 ft./lb. 65 ft./lb.
3/8	5	23 ft./lb.	8mm-1.25	8.8	19 ft./lb. 18 ft./lb.	12mm-1.5	8.8	66 ft./lb. 61 ft./lb.
7/16	5	37 ft./lb.	10mm-1.25	8.8	38 ft./lb. 36 ft./lb.	12mm-1.75	8.8	65 ft./lb. 60 ft./lb.
1/2	5	56 ft./lb.	10mm-1.5	8.8	37 ft./lb. 35 ft./lb.	14mm-2.0	8.8	104 ft./lb. 97 ft./lb.
5/8	5	150 ft./lb.						

All illustrations and specifications contained herein are based on the latest information available at the time of publication approval. ROADMASTER, INC. reserves the right to make changes at any time without notice in material, specification and models or to discontinue models.