



MOUNTING BRACKET KIT INSTALLATION INSTRUCTIONS

KIT# 521020-1

04/20/09
KS

ROADMASTER, Inc. 6110 NE 127th Ave. Vancouver, WA 98682 1-800-669-9690 fax 360-735-9300 www.roadmasterinc.com

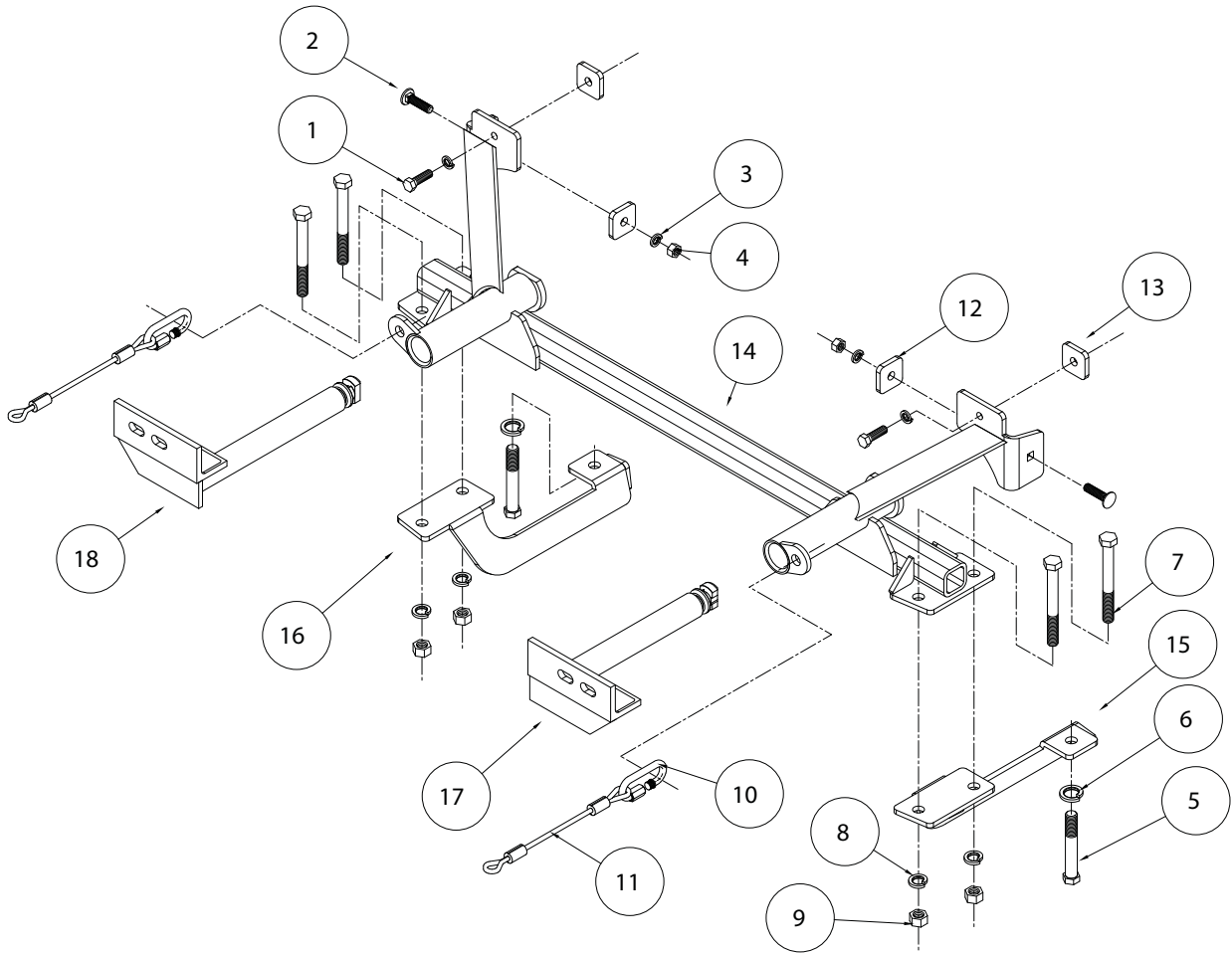

ITEM	QTY	NAME	MATERIAL
1.....	2	10mm x 1.50 x 30 mm BOLT	356101-00
2.....	2	10mm x 1.50 x 40 mm CARRIAGE BOLT.....	356103-50
3.....	4	10mm LOCK WASHER.....	355715-00
4.....	2	10mm x 1.50 HEX NUT.....	356230-00
5.....	2	14mm x 1.50 x 80 mm BOLT	357045-00
6.....	2	14mm LOCK WASHER.....	355740-00
7.....	4	1/2" x 4 1/2" BOLT.....	350106-00
8.....	4	1/2" LOCK WASHER	350309-00
9.....	4	1/2" HEX NUT	350258-00
10.....	2	QUICK LINK.....	200008-00
11.....	2	SAFETY CABLE 8"	650646-08
12.....	2	1/4" x 1 1/2" x 1 1/2" RD. HOLE BACKING PLATE	A-002116
13.....	2	1/4" x 1 1/2" x 1 1/2" M10 BACKING PLATE	C-001750
14.....	1	MAIN RECEIVER.....	C-001825
15.....	1	DRIVER SIDE BRACE.....	C-001826
16.....	1	PASSENGER SIDE BRACE	C-001827
17.....	1	DRIVER SIDE ARM	C-001828
18.....	1	PASSENGER SIDE ARM.....	C-001829



MOUNTING BRACKET KIT INSTALLATION INSTRUCTIONS

KIT# 521020-1

04/20/09
KS

ROADMASTER, Inc. 6110 NE 127th Ave. Vancouver, WA 98682 1-800-669-9690 fax 360-735-9300 www.roadmasterinc.com

This is one of our EZ2 series brackets, which allows the visible front portion of the bracket to be easily removed from the front of the vehicle (Fig.A and Fig.B). The bracket consists of a main receiver brace, two removable front braces, two center braces and a hardware pack.

The main receiver brace mounts to the frame rails and the bumper core. The removable front braces install in the main receiver brace.

Before starting the installation, lay out the kit components in order, as they will be used. This will give you a visual idea of how the components work, and will also confirm that everything is present and accounted for.



Fig.A



Fig.B

IMPORTANT: All brackets **must** be assembled with all the bolts left loose for final adjustment and positioning (before tightening) unless otherwise instructed. All bolts **must** be torqued for proper strength. If more than one bolt is used per fastening point, the diagram may only show one.

- Use flat washers over all slotted holes
- Use lock washers on all fasteners

WARNING

Failure to follow these instructions can result in property damage, personal injury or even death.

- Installation of most mounting brackets requires moderate mechanical aptitude and skills. We strongly recommend professional installation by an experienced installer.
- The installer must read the instructions and use all bolts and parts supplied. Failure to do so could result in loss of the towed vehicle.
- Use Loctite® Red on all bolts used for mounting this bracket.
- Do not use this document for custom fabrication, as it may not show all parts or structural components. Custom fabrication or an attempt to copy this bracket design could result in loss of the towed vehicle.
- Every 3,000 miles, the owner must inspect the fasteners for proper torque, according to the bolt torque requirements chart on the last page of these instructions. The owner must also inspect all mounts and brackets for cracks or other signs of fatigue every 3,000 miles. Failure to do so could result in loss of the towed vehicle.
- The owner must check the vehicle manufacturer's instructions for the proper procedure(s) to prepare the vehicle for towing. Some vehicles must be equipped with a transmission lube pump, an axle disconnect, driveline disconnect or free-wheeling hubs before they can be towed. Failure to properly equip the vehicle will cause severe damage to the transmission.
- If running changes were made by the vehicle manufacturer after this bracket was designed, some bolts or other fasteners in the hardware pack may no longer be the correct size. It is the installer's responsibility to verify that the bracket is securely fastened to the vehicle and fitted with the correct hardware to account for these changes. Failure to securely fasten the bracket could result in loss of the towed vehicle.
- If the towed vehicle has been in an accident, it must be properly repaired before attaching the bracket. Do not install the bracket if any structural frame damage is found. Failure to repair the damage could result in the loss of the towed vehicle.
- Some motorhome chassis have such a tight turning radius that you can damage your motorhome, towed vehicle, tow bar or bracket while turning sharply. Before getting on the road, test your turning radius in an empty parking lot. Turning too sharply could result in non-warranty damage to towing system, motorhome and/or towed vehicle.
- Do not back up with the towed vehicle attached or non-warranty damage will occur to your towing system, motorhome and/or towed vehicle.
- The safety cables must connect the towing vehicle to the towed vehicle frame to frame, with the cables crossed, with enough slack for sharp turns. Refer to the cable instructions for proper routing. Failure to leave enough slack in the safety cables, or failure to connect the safety cables frame to frame, will result in the loss of the towed vehicle.
- This bracket is designed for use with ROADMASTER tow bars and ROADMASTER adaptors only. Using this bracket with other brands, without an approved ROADMASTER adaptor, may result in non-warranty damage or injury.
- Upon final installation, the installer must inspect the bracket to ensure adequate clearance, particularly around hoses, air conditioner lines, radiators, etc., or non-warranty damage to the towed vehicle will result.
- This bracket is only warranted for the original installation. Installing a used bracket on another vehicle is not recommended and will void the warranty.



MOUNTING BRACKET KIT INSTALLATION INSTRUCTIONS

KIT# 521020-1

04/20/09
KS

ROADMASTER, Inc. 6110 NE 127th Ave. Vancouver, WA 98682 1-800-669-9690 fax 360-735-9300 www.roadmasterinc.com



1. **Important:** please use all supplied bolts and parts and read all instructions carefully before beginning this installation. The majority of questions you may have can be answered within the text, and proper installation will ensure safe and secure travel. Now, begin the installation by removing eight plastic fasteners attaching the grille and the top of the fascia to the core support (Fig.C).

2. Pull out and up to remove the grille (Fig.D).



3. Remove two 10mm (head) bolts attaching the center of the fascia to the core support (Fig.E).

4. Remove four plastic fasteners and one 10mm (head) bolt attaching the fender liner to the fascia (Fig.F and G).





MOUNTING BRACKET KIT INSTALLATION INSTRUCTIONS

KIT# 521020-1

04/20/09
KS

ROADMASTER, Inc. 6110 NE 127th Ave. Vancouver, WA 98682 1-800-669-9690 fax 360-735-9300 www.roadmasterinc.com

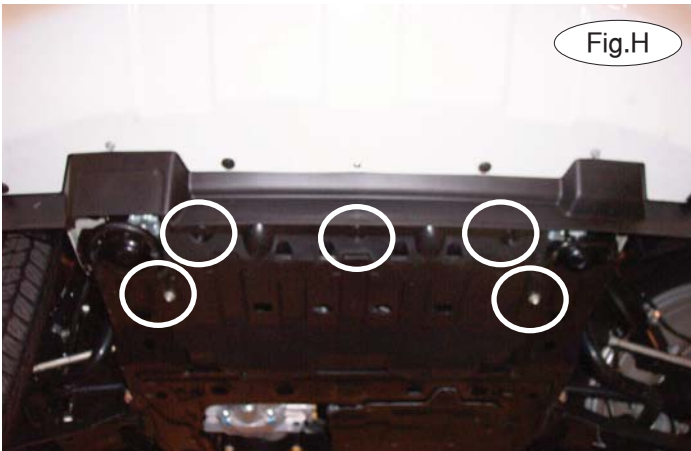

5. Remove two 10mm (head) bolts attaching the lower fascia to the bumper core and three plastic fasteners attaching the center splash shield to the bottom of the fascia (Fig.H).

6. Pull out and forward to remove the fascia. Disconnect the fog lights and ambient temperature sensor, if the vehicle is so equipped (Fig.I).



7. On each side, remove three 10mm (head) bolts attaching the headlight to the core support. Unplug the headlight, and set it aside (Fig.J).

8. On the passenger side only, remove one 10mm (head) bolt attaching the air box to the core support (Fig.K). Pull the air box down and slightly away from the side of the frame (Fig.L).





MOUNTING BRACKET KIT INSTALLATION INSTRUCTIONS

KIT# 521020-1

04/20/09
KS

ROADMASTER, Inc. 6110 NE 127th Ave. Vancouver, WA 98682 1-800-669-9690 fax 360-735-9300 www.roadmasterinc.com



9. Remove one plastic fastener attaching the washer bottle neck to the core support. Pull up on the washer bottle neck to remove it from the washer bottle (Fig.M).

10. Remove four 10mm (head) bolts attaching the washer bottle to the side of the frame (Fig.N). *Note:* only three are visible in Figure N. The fourth bolt is located behind the washer bottle, on the lower right corner of the bottle.

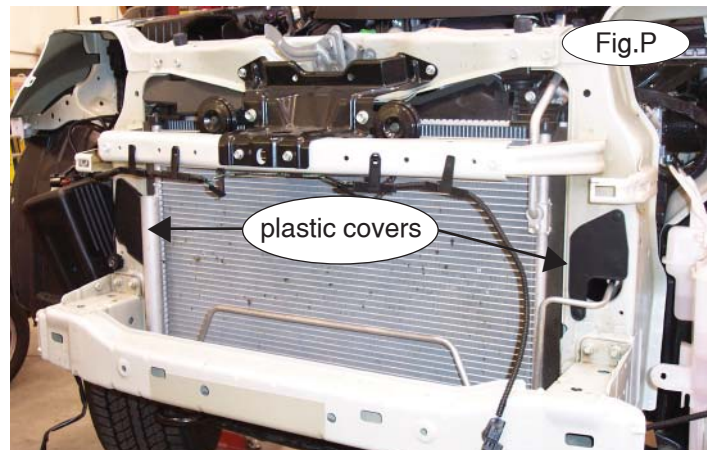
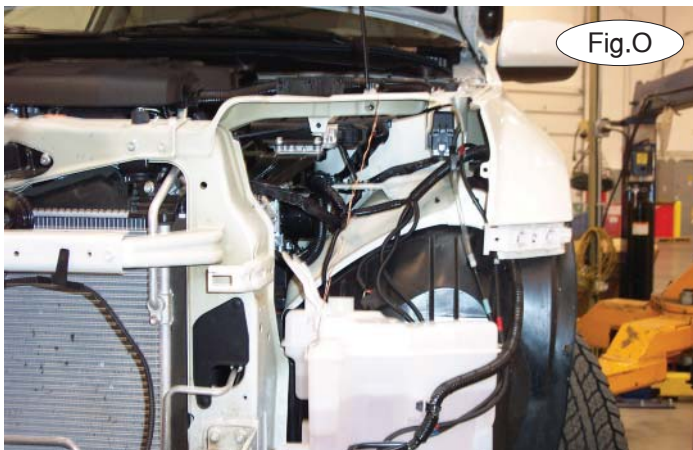

11. Use wire or zip ties to suspend the washer bottle (Fig.O). *Note:* the washer bottle can also be removed, but make certain to mark all hoses and lines for replacement.

12. Remove two plastic covers located on the front of the core support (Fig.P). *Note:* the covers will not be replaced. Retain the covers so that they can be replaced if the bracket is ever removed.

13. Set the main receiver brace over the top of the bumper core, aligning it with the pre-existing holes in the core support (Fig.Q).





MOUNTING BRACKET KIT INSTALLATION INSTRUCTIONS

KIT# 521020-1

04/20/09
KS

ROADMASTER, Inc. 6110 NE 127th Ave. Vancouver, WA 98682 1-800-669-9690 fax 360-735-9300 www.roadmasterinc.com



14. Working on the driver's side only, place one of the supplied $\frac{1}{2}$ " x $4\frac{1}{2}$ " bolts through the pre-existing hole in the main receiver brace and the bumper core (Fig.R).

15. Remove a 19mm (head) subframe bolt (Fig.S). *Note:* the bolt will not be replaced. Retain the bolt so that it can be replaced if the bracket is ever removed.

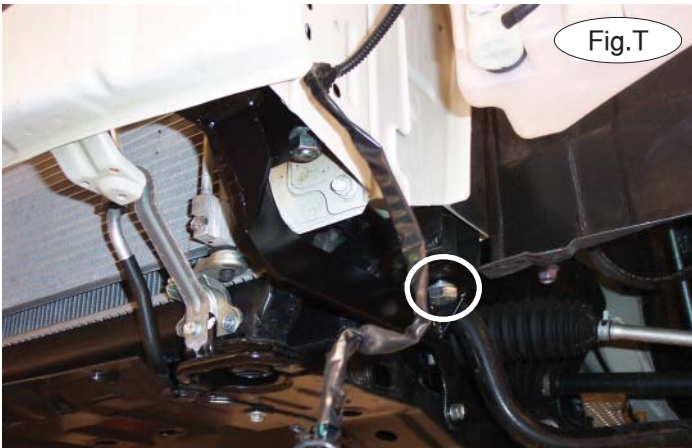

16. Place the driver's side rear brace over the hole you exposed in the previous step, and using a supplied 14mm x 1.5 x 80mm bolt with thread lock, bolt through the rear mounting point and subframe and lock washer.

Place a $\frac{1}{2}$ " lock washer and nut over the $\frac{1}{2}$ " front bolt you installed in step 14 (Fig.T). Tighten all bolts to the bolt torque requirements found at the end of this document.

17. Repeat steps 14 and 16 for the passenger side of the vehicle.

18. Working on the driver's side, place a 10mm x 1.5 x 40mm carriage bolt through the upper support of the main receiver brace and the core support.

Reaching around the backside of the frame, place a $\frac{1}{4}$ " x $1\frac{1}{2}$ " x $1\frac{1}{2}$ " backing plate over the carriage bolt and bolt it into place using a 10mm lock washer and nut (Fig.U).

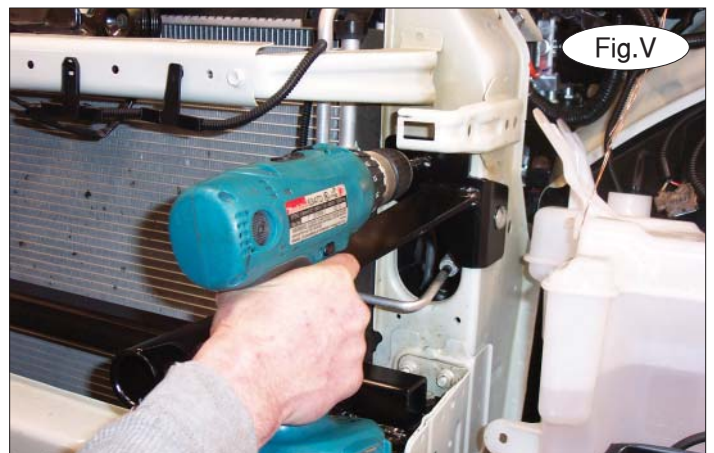

19. Using a 10mm drill bit and the side mounting point on the upper support as a template, drill a 10mm hole through the core support (Fig.V).



MOUNTING BRACKET KIT INSTALLATION INSTRUCTIONS

KIT# 521020-1

04/20/09
KS

ROADMASTER, Inc. 6110 NE 127th Ave. Vancouver, WA 98682 1-800-669-9690 fax 360-735-9300 www.roadmasterinc.com

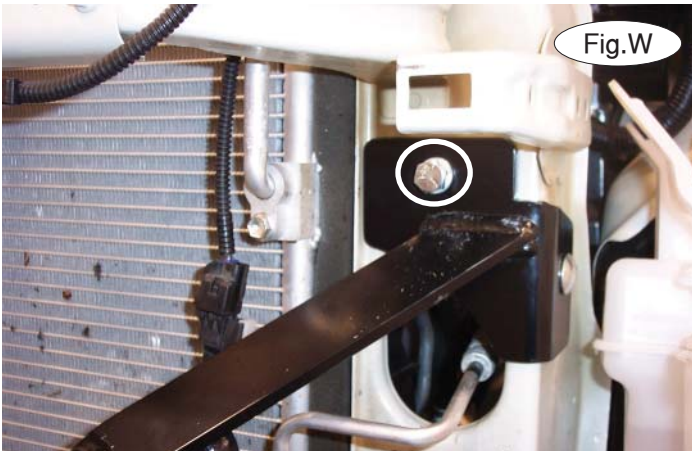

20. Place a 10mm lock washer over a 10mm x 1.5 x 30mm bolt. Place a 1/4" x 1 1/2" x 1 1/2" nutted backing plate into the core support. Bolt through the main receiver brace, core support and into the backing plate (Fig.W).

21. Repeat steps 18 through 20 for the passenger side of the vehicle.

22. On each side, use the front mounting point of the main receiver brace as a template, drill through the top and bottom of the bumper core (Fig.X).



23. On each side, use a 1/2" x 4 1/2" bolt to bolt through the main receiver brace, top and bottom of the bumper core and into the rear support brace. Finish with a 1/2" lock washer and nut (Fig.Y).

24. Tighten all the bolts to the bolt torque requirements found at the end of this document.

25. Trim the fascia using the yellow lines in Figure Z as a guide for trimming.

26. Reassemble the fascia, reversing steps 1 through 6.

27. Insert the removable front bracket arms into the front receiver braces, and twist each one 90 degrees to lock.

28. Attach the 8" safety cables with the cable connectors (Q-Links) to bottom cross bar of the main brace.

29. Attach the ends of the safety cables to the tow vehicle's safety cables.

30. Install the tow bar to the mounting bracket according to the manufacturer's instructions.



MOUNTING BRACKET KIT INSTALLATION INSTRUCTIONS

KIT# 521020-1

04/20/09
KS

ROADMASTER, Inc. 6110 NE 127th Ave. Vancouver, WA 98682 1-800-669-9690 fax 360-735-9300 www.roadmasterinc.com

BOLT TORQUE REQUIREMENTS

Note: The torque values represented below are intended as general guidelines. Torque requirements for specific applications may vary. Roadmaster does not warrant this information to be accurate for all applications and disclaims all liability for any claims or damages which may result from its use.

STANDARD BOLTS

Thread Size	Grade	Torque
5/16.....	5.....	13 ft./lb.
3/8.....	5.....	23 ft./lb.
7/16.....	5.....	37 ft./lb.
1/2.....	5.....	56 ft./lb.
5/8.....	5.....	150 ft./lb.

METRIC BOLTS

Thread Size	Grade	Plated / Unplated
8mm-1.0.....	8.8.....	20 ft./lb. 18 ft./lb.
8mm-1.25.....	8.8.....	19 ft./lb. 18 ft./lb.
10mm-1.25.....	8.8.....	38 ft./lb. 36 ft./lb.
10mm-1.5.....	8.8.....	37 ft./lb. 35 ft./lb.

METRIC BOLTS

Thread Size	Grade	Plated / Unplated
12mm-1.25.....	8.8.....	70 ft./lb. 65 ft./lb.
12mm-1.5.....	8.8.....	66 ft./lb. 61 ft./lb.
12mm-1.75.....	8.8.....	65 ft./lb. 60 ft./lb.
14mm-2.0.....	8.8.....	104 ft./lb. 97 ft./lb.

All illustrations and specifications contained herein are based on the latest information available at the time of publication approval. ROADMASTER, INC. reserves the right to make changes at any time without notice in material, specification and models or to discontinue models.