



BASEPLATE KIT INSTALLATION INSTRUCTIONS

ROADMASTER, Inc. 6110 NE 127th Ave. Vancouver, WA 98682 360-896-0407 fax 360-735-9300 www.roadmasterinc.com

PARTS LIST:

- 1- FRONT BRACE (A) - Passenger side
- 1- FRONT BRACE (B) - Driver side
- 1- MAIN BRACE (C) - Passenger side
- 1- MAIN BRACE (D) - Driver side

KIT NO. 521157-3

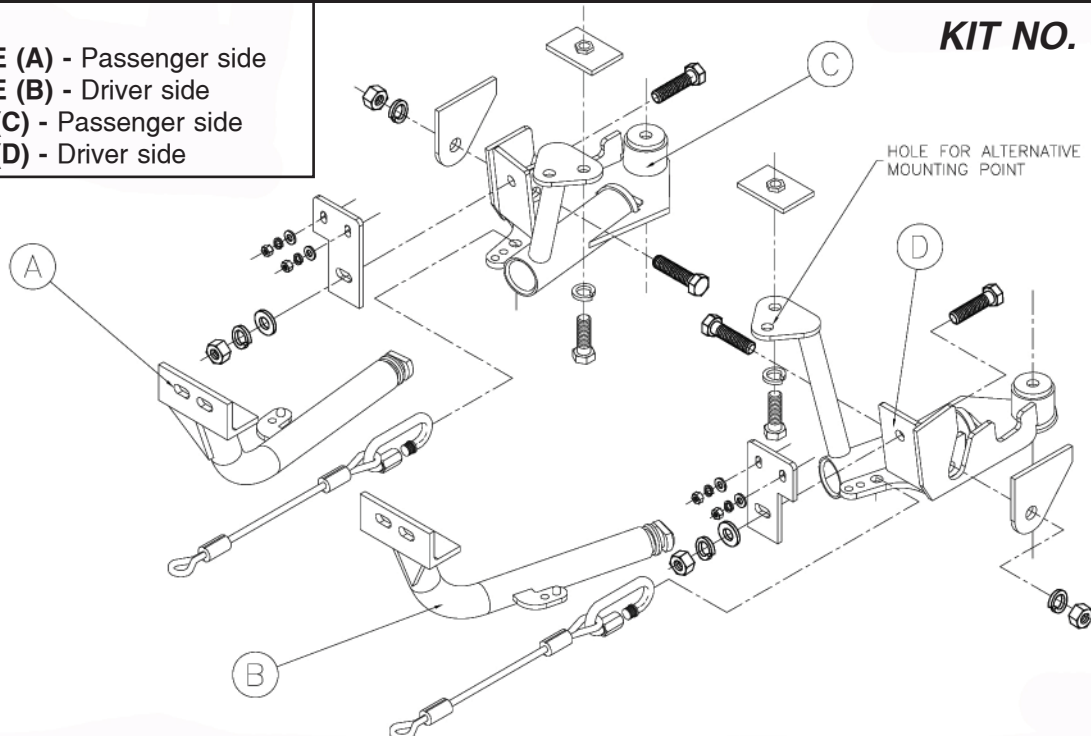

IMPORTANT: All baseplates **must** be assembled with all the bolts left loose for final adjustment and positioning (before tightening) unless otherwise instructed. All bolts **must** be torqued for proper strength. If more than one bolt is used per fastening point, the diagram may only show one. Use flat washers over all slotted holes and lock washers on all fasteners.

WARNING

Failure to heed these warnings or follow the installation instructions may result in a voided warranty, loss of towed vehicle, personal injury or death.

- Do not weld or modify this baseplate or its components. Welding or modification will void the warranty.
- Do not use this document as a basis to design/fabricate a baseplate, as it may not show all parts or structural components.
- We strongly recommend professional installation.
- If the towed vehicle has been in an accident, it must be properly repaired before attaching the baseplate. **Do not install the baseplate if any structural frame damage is found.**
- The installer must use all bolts and parts supplied. If running changes were made by the vehicle manufacturer after this kit was designed, some bolts or other fasteners may no longer be the correct size. **It is the installer's responsibility to verify this kit is securely fastened to the vehicle.**
- Use **Loctite® Red on all bolts used to secure this baseplate.** Torque all bolts to the specifications found at the end of these instructions. **Do not over-torque the bolts or failure may occur.**
- The installer must inspect the baseplate to ensure adequate clearance, particularly around hoses, air conditioner lines, radiators, etc. or non-warranty failure may result.
- Roadmaster manufactures many styles of baseplates. **If your baseplate has removable arms, they must be removed before driving the vehicle, unless the arms can be pinned or padlocked in place.** If not secured, the arms could vibrate out.
- Some motorhome chassis have such a tight turning radius that you can damage your motorhome, towed vehicle, tow bar or baseplate while turning sharply. **Before getting on the road, test your turning radius in an empty parking lot.** Turning too sharply could result in non-warranty damage to your towing system, motorhome and/or towed vehicle.
- Do not back up with the towed vehicle attached or non-warranty damage will occur to your towing system or vehicles.
- The safety cables must connect the towing vehicle to the towed vehicle frame to frame, with the cables crossed, with enough slack for sharp turns. See cable instructions for proper routing. Failure to do so will result in non-warranty damage and/or the loss of the towed vehicle.
- This kit is designed for use with ROADMASTER tow bars and ROADMASTER adapters only. **Using this kit with other brands, without an approved ROADMASTER adapter, may result in non-warranty damage or injury.**
- Receiver extensions and out-of-level towing situations of 3 inches or more. This can cause the system to swing much higher and lower, causing excessive strain on the tow bar, baseplate and frame. That can cause the towing system to fail, causing property damage, personal injury or even death. **If you must use a receiver extension or drop hitch to tow, it will reduce your receiver's weight capacity by 1/3 to avoid damaging your system. Never use more than one extension and/or drop hitch, as this will void your warranty.**
- Every 3,000 miles, the owner must inspect all mounting points for cracks or fatigue, and check the fasteners for proper torque, according to the bolt torque requirements chart on the last page of these instructions.
- The owner must follow the vehicle manufacturer's instructions to prepare the vehicle for towing. Failure to do so may cause severe damage to the vehicle.
- This baseplate is only warranted for the original installation. Installing a used baseplate on another vehicle is not recommended and will void the warranty.



BASEPLATE KIT INSTALLATION INSTRUCTIONS

ROADMASTER, Inc. 6110 NE 127th Ave. Vancouver, WA 98682 360-896-0407 fax 360-735-9300 www.roadmasterinc.com

KIT NO. 521157-3

- Important:** please use all supplied bolts and parts and read all instructions carefully before beginning this installation. The majority of questions you may have can be answered within the text, and proper installation will ensure safe and secure travel. Now, begin the installation. This is one of our EZ lock bracket series, which allows the visible front portion of the brackets to be easily removed from the front of the car by rotating the front braces. The bracket kit consists of two main receiver braces, two tubular front braces and a hardware pack. The rear receiver braces mount to the bottom and side of the sub frame and protrude below the lower grill and the bumper fascia. The front tubular braces insert into the rear braces and rotate 90 degrees to lock in place. The back of the lower bumper fascia will have to be trimmed to fit in front of the main receiver brace. The lower splash shields will be loosened in front then trimmed to fit later. Before starting the installation, lay out the kit components as it is illustrated. This will give you a visual idea of how the components work and also confirm that everything is present and accounted for.
- Begin by removing eight 10mm head bolts holding the two lower splash panels to the sub frame and lower fascia. This will provide access to the sub frame mounting area.
- Starting with the driver side, hold the driver side receiver brace inside the front tie down plate with the rear mounting hole over the rear sub frame mounting bolt. Mark the lower bumper fascia and trim to allow the receiver brace to go up in position.
- Remove the large 19mm head sub frame mounting bolt and bolt through the rear of the receiver brace. Now bolt through the side of the brace with a 5/8" x 1 3/4" bolt, 1/4" x 2" x 3" backing plate, lock washer and nut.
- Install the upper brace over the small studs located behind the bumper fascia and bolt in place using the supplied 8mm fender washers, lock washers and nuts. Bolt through the lower mounting hole and receiver brace with a 1/2" x 1 1/4" bolt, flat washer, lock washer and nut.
- At this point check the receiver brace alignment and tighten all bolts to the torque specifications below. Make sure the bumper core mounting pad is located beneath the bumper core, then locate which mounting hole lines up with the center of the bumper core and drill a 17/32" hole through the lower portion of the bumper core using the brace as a drill guide. Now bolt through the receiver brace mounting plate and bumper core with a 1/2" x 2 1/2" bolt and lock washer, using the threaded backing plate on the top lower channel of the bumper core. Tighten to the torque specifications below.
- Repeat steps 3 through 6 for the passenger side receiver brace.
- Install the front braces by inserting with front braces vertical to the ground, push in and twist down 90 degrees to lock in place.
- Trim the lower splash shields to fit, then replace fasteners removed in step 2. Note: one front fastener on each side will not be used.
- Mount the tow bar according to the tow bar manufacturer's instructions. Install the 12" safety cables to the side of the main receiver portion of the bracket with quick links provided. Attach the other end to the tow vehicle's safety cables and the tow bar.

BOLT TORQUE REQUIREMENTS

Note: The torque values represented below are intended as general guidelines. Torque requirements for specific applications may vary. Roadmaster does not warrant this information to be accurate for all applications and disclaims all liability for any claims or damages which may result from its use.

STANDARD BOLTS

Thread Size	Grade	Torque
5/16.....	5.....	13 ft./lb.
3/8.....	5.....	23 ft./lb.
7/16.....	5.....	37 ft./lb.
1/2.....	5.....	56 ft./lb.
5/8.....	5.....	150 ft./lb.

METRIC BOLTS

Thread Size	Grade	Plated / Unplated
8mm-1.0.....	8.8.....	20 ft./lb. 18 ft./lb.
8mm-1.25.....	8.8.....	19 ft./lb. 18 ft./lb.
10mm-1.25.....	8.8.....	38 ft./lb. 36 ft./lb.
10mm-1.5.....	8.8.....	37 ft./lb. 35 ft./lb.

METRIC BOLTS

Thread Size	Grade	Plated / Unplated
12mm-1.25.....	8.8.....	70 ft./lb. 65 ft./lb.
12mm-1.5.....	8.8.....	66 ft./lb. 61 ft./lb.
12mm-1.75.....	8.8.....	65 ft./lb. 60 ft./lb.
14mm-2.0.....	8.8.....	104 ft./lb. 97 ft./lb.



BASEPLATE KIT INSTALLATION INSTRUCTIONS

ROADMASTER, Inc. 6110 NE 127th Ave. Vancouver, WA 98682 360-896-0407 fax 360-735-9300 www.roadmasterinc.com

KIT NO. 521157-3

Hardware list

- 4- 8mm x 1.25 nuts
- 4- 8mm fender washers
- 4- 8mm lock washers
- 2- 5/8" x 1 3/4" bolts
- 2- 5/8" nuts
- 2- 5/8" lock washers
- 2- 1/2" x 1 1/4" bolts
- 2- 1/2" x 2 1/2" bolts
- 2- 1/2" nuts
- 4- 1/2" lock washers
- 2- 1/2" flat washers
- 2- 1/4" backing plates
- 2- 1/4" x 2" x 3" threaded backing plates
- 2- bumper braces
- 2-12" safety cables
- 2-quick links

08/08/13

BOLT TORQUE REQUIREMENTS

Note: The torque values represented below are intended as general guidelines. Torque requirements for specific applications may vary. Roadmaster does not warrant this information to be accurate for all applications and disclaims all liability for any claims or damages which may result from its use.

STANDARD BOLTS

Thread Size	Grade	Torque
5/16.....	5.....	13 ft./lb.
3/8.....	5.....	23 ft./lb.
7/16.....	5.....	37 ft./lb.
1/2.....	5.....	56 ft./lb.
5/8.....	5.....	150 ft./lb.

METRIC BOLTS

Thread Size	Grade	Plated / Unplated
8mm-1.0.....	8.8.....	20 ft./lb. 18 ft./lb.
8mm-1.25.....	8.8.....	19 ft./lb. 18 ft./lb.
10mm-1.25.....	8.8.....	38 ft./lb. 36 ft./lb.
10mm-1.5.....	8.8.....	37 ft./lb. 35 ft./lb.

METRIC BOLTS

Thread Size	Grade	Plated / Unplated
12mm-1.25.....	8.8.....	70 ft./lb. 65 ft./lb.
12mm-1.5.....	8.8.....	66 ft./lb. 61 ft./lb.
12mm-1.75.....	8.8.....	65 ft./lb. 60 ft./lb.
14mm-2.0.....	8.8.....	104 ft./lb. 97 ft./lb.

All illustrations and specifications contained herein are based on the latest information available at the time of publication approval. ROADMASTER, INC. reserves the right to make changes at any time without notice in material, specification and models or to discontinue models.