



MOUNTING BRACKET KIT INSTALLATION INSTRUCTIONS

KIT# 521423-1

07/09/09
KS

ROADMASTER, Inc. 6110 NE 127th Ave. Vancouver, WA 98682 1-800-669-9690 fax 360-735-9300 www.roadmasterinc.com

ROADMASTER, INC.

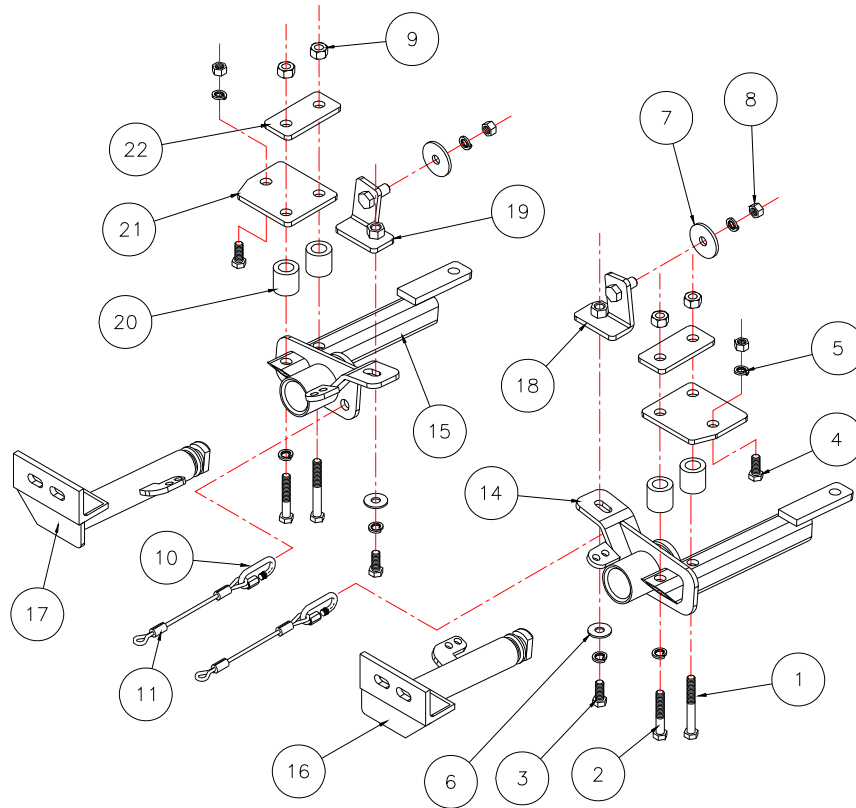

Item	Qty.	Description	Part No.
1	2	1/2" x 4 1/2" BOLT	350106-00
2	2	1/2" x 3" BOLT	350101-00
3	2	1/2" x 1 1/4" BOLT	350094-00
4	2	1/2" x 1 1/2" BOLT	350095-00
5	8	1/2" LOCK WASHER	350309-00
6	2	1/2" FLAT WASHER	350308-00
7	2	1/2" PLATE WASHER	350351-00
8	4	1/2" NC NUT	350258-00
9	4	1/2" NYLOCK NUT	350259-00
10	2	CABLE CONNECTOR	200008-00
11	2	8" SAFETY CABLE	500646-08
12	1	LOCK-TITE #262	200544-00
13	8	3/16" x 1" PLASTIC PULL RIVET	350431-00
14	1	DRIVER SIDE RECEIVER BRACE	C-000419
15	1	PASSENGER SIDE RECEIVER BRACE	C-000420
16	1	DRIVER SIDE ARM BRACE	C-000421
17	1	PASSENGER SIDE ARM BRACE	C-000422
18	1	DRIVER SIDE BUMPER CORE BRACE	C-000208
19	1	PASSENGER SIDE BUMPER CORE BRACE	C-000209
20	4	1 1/4" O.D. x 1 1/4" ROUND TUBE	A-000964
21	2	BACKING PLATE - 3 HOLES	A-000965
22	2	BACKING PLATE - 2 HOLES	A-000966



MOUNTING BRACKET KIT INSTALLATION INSTRUCTIONS

KIT# 521423-1

07/09/09
KS

ROADMASTER, Inc. 6110 NE 127th Ave. Vancouver, WA 98682 1-800-669-9690 fax 360-735-9300 www.roadmasterinc.com

This is one of our EZ series brackets, which allows the visible front portion of the bracket to be easily removed from the front of the vehicle (Fig.A and Fig.B). The bracket consists of two main receiver braces, two removable front braces and a hardware pack.

The main receiver brace mounts below the bumper core behind the front bumper fascia and through existing openings in the bumper fascia. The front grille and bumper fascia have to be removed to install the receiver braces. Fascia fender rivets will have to be removed and replaced with new rivets included in the hardware kit. The removable front braces install in the receiver braces by inserting and twisting 90 degrees to lock.

Before starting the installation, lay out the kit components in order, as they will be used. This will give you a visual idea of how the components work, and will also confirm that everything is present and accounted for.



Fig.A



Fig.B

IMPORTANT: All brackets **must** be assembled with all the bolts left loose for final adjustment and positioning (before tightening) unless otherwise instructed. All bolts **must** be torqued for proper strength. If more than one bolt is used per fastening point, the diagram may only show one.

- Use flat washers over all slotted holes
- Use lock washers on all fasteners

ROADMASTER Limited Warranty, including One-Year Conditional Warranty Text and Product Registration Card, in Carton.

WARNING

- Do not use this document for custom fabrication, as it may not show all parts or structural components. Custom fabrication or an attempt to copy this bracket design could result in loss of the towed vehicle.
- The owner must inspect all mounts and brackets before each use for cracks or other signs of fatigue. Also, inspect the fasteners for proper torque, according to the bolt torque requirements chart on the last page. Failure to do so could result in loss of the towed vehicle.
- The owner must check the manufacturer's instructions for the proper procedure(s) to prepare the vehicle for towing. Some vehicles must be equipped with a transmission lube pump, an axle disconnect, driveline disconnect or free-wheeling hubs before they can be towed. Failure to properly equip the vehicle will cause severe damage to the transmission.
- The installer must read the instructions and use all bolts and parts supplied. Failure to securely fasten the bracket could result in loss of the towed vehicle.
- If running changes were made by the vehicle manufacturer after this bracket was designed, some bolts or other fasteners in the included hardware pack may no longer be the correct size. It is the installer's responsibility to verify that the bracket is securely fastened to the vehicle, and fitted with the correct hardware, to account for these changes. Failure to securely fasten the bracket could result in loss of the towed vehicle.
- If the towed vehicle has been in an accident, it must be properly repaired before attaching the bracket. Do not install the bracket if any structural frame damage is found. Failure to repair the damage may result in the loss of the towed vehicle.

- Some motorhome chassis have such a tight turning radius that you can damage your motorhome, towed vehicle, tow bar or bracket while turning sharply. Before getting on the road, test your turning radius in an empty parking lot. Turning too sharply could result in non-warranty damage to towing system, motorhome and/or towed vehicle.
- Do not back up with the towed vehicle attached or non-warranty damage will occur to your towing system, motorhome and/or towed vehicle.
- The safety cables must connect the towing vehicle to the towed vehicle frame to frame, with the cables crossed, with enough slack for sharp turns. Refer to the cable instructions for proper routing. Failure to leave enough slack in the safety cables, or failure to connect the safety cables frame to frame, will result in the loss of the towed vehicle.
- This bracket is designed for use with ROADMASTER tow bars and ROADMASTER adaptors only. Using this bracket with other brands, without an approved ROADMASTER adaptor, may result in non-warranty damage or injury.
- Upon final installation, the installer must inspect the bracket to ensure adequate clearance, particularly around hoses, air conditioner lines, radiators, etc., or non-warranty damage to the towed vehicle will result.
- This bracket is only warranted for the original installation. Installing a used bracket on another vehicle is not recommended and will void the warranty.

WARNING

Failure to follow these instructions can result in property damage, personal injury or even death.



MOUNTING BRACKET KIT INSTALLATION INSTRUCTIONS

KIT# 521423-1

07/09/09
KS

ROADMASTER, Inc. 6110 NE 127th Ave. Vancouver, WA 98682 1-800-669-9690 fax 360-735-9300 www.roadmasterinc.com

Notice – 2005-07 Jeep Liberty installation supplement

To remove the fascia on 2005-2007 Jeep Liberty installations, proceed to the supplement on the last two pages of these instructions. The supplement supersedes steps 1 through 5 below.



1. Start by removing four bolts (10mm head) from the middle of the lower fascia (Fig.C).
2. Go to the top of the vehicle between the headlights and remove four grill fasteners (*20 torx). Pull forward and down to remove the grill (Fig.D, E).



3. Remove four plastic fasteners holding the top of the fascia between the headlights (Fig.F).
4. Drill four rivets in each fender well lip holding the fascia to the fender well lip and remove (Fig.G).
5. Pull out on the fascia lip while simultaneously squeezing the side clips to release, starting with the bottom clip on each side (Fig.H) then lift up to unhook the fascia, pull forward and off (Fig.I).



6. Remove four nuts (17mm or 18mm) holding the stabilizer bar to the bottom of the frame (two per side) then remove the stabilizer bar mounts and pull down on the stabilizer bar (Fig.J).
7. Remove the black covers over the frame openings on each side (two 10mm head bolts) (Fig.K).



MOUNTING BRACKET KIT INSTALLATION INSTRUCTIONS

KIT# 521423-1

07/09/09
KS

ROADMASTER, Inc. 6110 NE 127th Ave. Vancouver, WA 98682 1-800-669-9690 fax 360-735-9300 www.roadmasterinc.com



8. If tow hooks are present, remove at this time, (three 15mm nuts per hook) and the mounting u-bolt and spring nut (Fig.L, M, N). Keep them for replacement if the towing system is ever removed from the vehicle.
9. Enlarge the tow hook mounting holes to 17/32" (two holes per side under the frame) (Fig.L).



10. Insert the two hole backing plates in the frame on each side over the tow hook mounting holes (Fig.O).
11. Look under the bumper core and locate the large square holes in the bottom of the bumper core on each side (Fig.P). Put the driver side backing plate weldment through these holes on each side over the existing holes located approximately 1½" inboard from the large access holes. Put the bolts in the braces through existing holes in the back of the bumper core. If they don't line up you may have the drivers side in the passenger side. Try switching them around (Fig.Q). Bolt the braces to the rear of the bumper core into the upper braces with ½" nuts, plate washers and lock washers. The bottom of the braces should be in line with the existing holes in the bottom of the bumper core at this time.

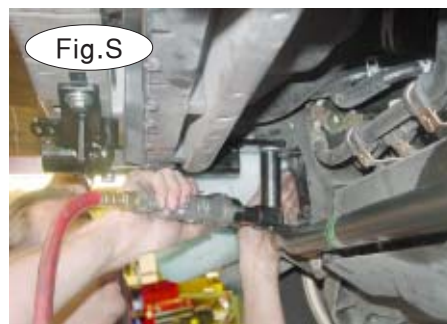

12. Starting with the driver side, remove a large sub frame bolt (19mm or 21mm head) located above the sway bar mounting area (Fig.R). Take the driver side receiver brace and bolt through the rear-mounting hole with this bolt (Fig.S). *Note:* use the included Lock-Tite on the bolt before reinstalling (Fig.T).



MOUNTING BRACKET KIT INSTALLATION INSTRUCTIONS

KIT# 521423-1

07/09/09
KS

ROADMASTER, Inc. 6110 NE 127th Ave. Vancouver, WA 98682 1-800-669-9690 fax 360-735-9300 www.roadmasterinc.com

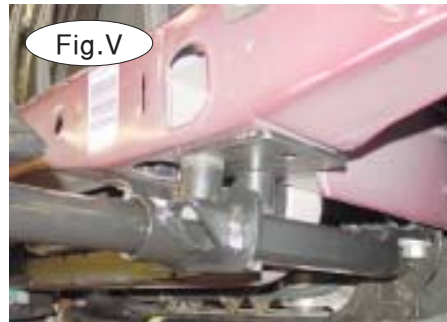

13. There are two holes located in the front outside of the receiver braces. Using one of the supplied 1/2" x 4" bolts and nylock nuts, bolt through the second hole back in the driver side receiver brace, one of the supplied three-hole lower backing plates, the frame, and one of the supplied two-hole backing plates and 1 1/4" spacers (Fig.U).

14. Bolt through the front mounting hole in the receiver brace, three hole backing plate, frame and two hole backing plate and 1 1/4" spacer with a 1/2" x 3" bolt, and Nylock nut (Fig.V).

15. Bolt through the lower side of the receiver brace into the bottom of the bumper core and top brace installed in step 11, with a 1/2" x 1 1/2" lock washer and flat washer.

16. Torque all mounting bolts to the specifications listed at the bottom of these instructions. Then, using the three hole plates as drill templates, drill two 17/32" holes into the frame (Fig.W).



17. Bolt through these holes with 1/2" x 1 1/2" bolts, lock washers and nuts (Fig.X). *Note:* loosen the water bottle on the passenger side (two 10mm head bolts) to gain access to the rear of the frame, then remount (Fig.X).

18. Reinstall the sway bar, reversing step 6 (Fig.Y).

19. Reinstall the bumper fascia and grille, reversing steps 3 through 6. *Note:* new rivets are supplied in the hardware pack.

20. Insert the removable front braces into the main receiver braces, and twist each one 90 degrees to lock (Fig.Z). Attach the 8" safety cables with the cable connectors (Q-links) to the front of the receiver braces.

21. Attach the ends of the safety cables to the tow vehicle's safety cables and tow bar.

22. Install the tow bar to the mounting bracket according to the manufacturer's instructions.

BOLT TORQUE REQUIREMENTS

Note: The torque values represented below are intended as general guidelines. Torque requirements for specific applications may vary. Roadmaster does not warrant this information to be accurate for all applications and disclaims all liability for any claims or damages which may result from its use.

STANDARD BOLTS			METRIC BOLTS			METRIC BOLTS		
Thread Size	Grade	Torque	Thread Size	Grade	Plated / Unplated	Thread Size	Grade	Plated / Unplated
5/16	5	13 ft./lb.	8mm-1.0	8.8	20 ft./lb. 18 ft./lb.	12mm-1.25	8.8	70 ft./lb. 65 ft./lb.
3/8	5	23 ft./lb.	8mm-1.25	8.8	19 ft./lb. 18 ft./lb.	12mm-1.5	8.8	66 ft./lb. 61 ft./lb.
7/16	5	37 ft./lb.	10mm-1.25	8.8	38 ft./lb. 36 ft./lb.	12mm-1.75	8.8	65 ft./lb. 60 ft./lb.
1/2	5	56 ft./lb.	10mm-1.5	8.8	37 ft./lb. 35 ft./lb.	14mm-2.0	8.8	104 ft./lb. 97 ft./lb.
5/8	5	150 ft./lb.						

All illustrations and specifications contained herein are based on the latest information available at the time of publication approval. ROADMASTER, INC. reserves the right to make changes at any time without notice in material, specification and models or to discontinue models.



MOUNTING BRACKET KIT INSTALLATION INSTRUCTIONS

KIT# 521423-1

07/09/09
KS

ROADMASTER, Inc. 6110 NE 127th Ave. Vancouver, WA 98682 1-800-669-9690 fax 360-735-9300 www.roadmasterinc.com

Fascia Removal Supplement – 2005-07 Jeep Liberty

This supplement supersedes steps 1 through 5 in the mounting bracket installation instructions.



1. Unsnap the six plastic tabs on the top of the grille (Fig.A) and remove the grille. (Some models may have two T25 Torx bolts on the grille. If this is the case, remove them as well.)
2. If the vehicle is equipped with fog lights, use a T30 Torx to remove the fog light mounting bolt (Fig.B).
3. Unplug the wiring harness. Lift the plastic and pull the harness through to remove the fog light (Fig.C).

4. Remove the two 10mm bolts on the fascia. There is one on each side (Fig.D).

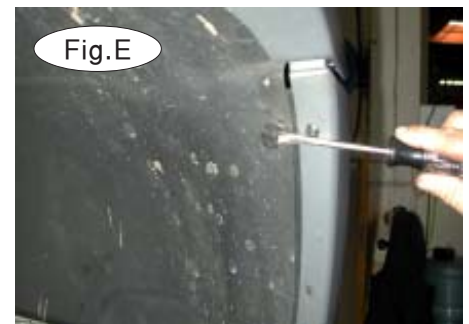

5. On each fender well, remove the two plastic fasteners that connect the fascia to the fender liner (Fig.E).

6. On the underside of the fascia, remove the two 10mm bolts (Fig.F) and the two plastic fasteners (Fig.G).



7. Pull down and away on each side of the front fascia (Fig.H), and remove the marker lights (Fig.I) and the turn signal plugs (Fig.J). Remove the fascia.

**Fascia Removal Supplement
continues on next page.**





MOUNTING BRACKET KIT INSTALLATION INSTRUCTIONS

KIT# 521423-1

07/09/09
KS

ROADMASTER, Inc. 6110 NE 127th Ave. Vancouver, WA 98682 1-800-669-9690 fax 360-735-9300 www.roadmasterinc.com

Fascia Removal Supplement – 2005-07 Jeep Liberty

continued from preceding page

This supplement supersedes steps 1 through 5 in the mounting bracket installation instructions.

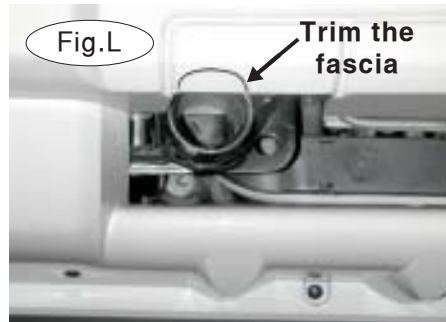

8. After installing the tow bar bracket, a small portion of the air deflector will need to be trimmed before re-installing the fascia. Refer to the white mark in Figure K.

9. After trimming the air deflector, reinstall the fascia by reversing steps 1 through 7 in this supplement.

10. Some models do not have tow hook openings in the fascia. If this is the case, a small portion of the fascia (on each side) will have to be trimmed to accommodate the removable front bracket arms. Use the black line in Figure L as a reference. Figure M shows the fascia trimmed, and Figure N shows the removable front bracket arm in place.



**Proceed to step 6 In the mounting bracket kit
installation instructions.**