



BASEPLATE KIT INSTALLATION INSTRUCTIONS

KIT# 521558-1

03/04/08
KS

ROADMASTER, Inc. 6110 NE 127th Ave. Vancouver, WA 98682 1-800-669-9690 fax 360-735-9300 www.roadmasterinc.com

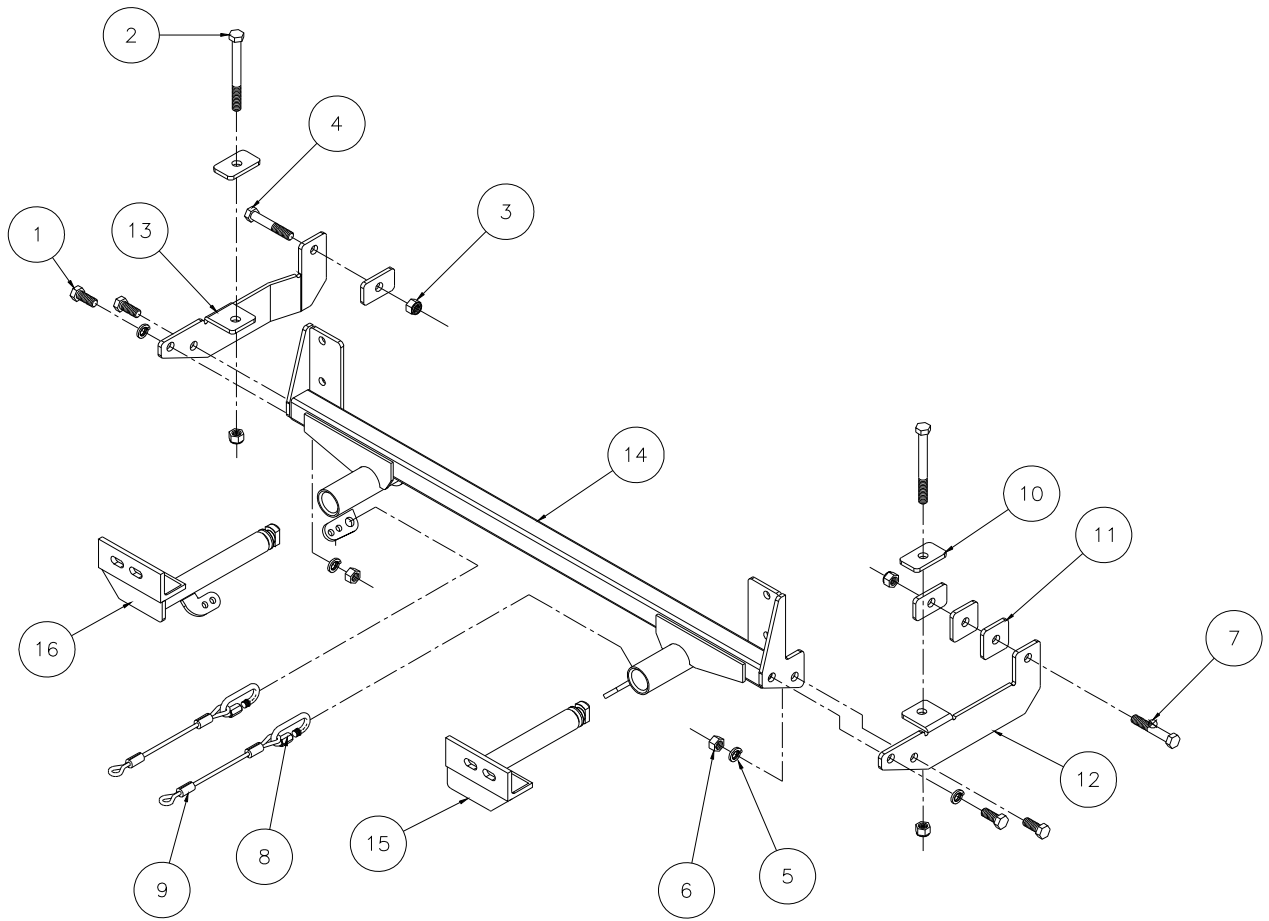

ITEM	QTY	NAME	MATERIAL
1	4	1/2" x 1 1/4" BOLT	350094-00
2	2	1/2" x 5 1/2" BOLT	350108-00
3	4	1/2" NYLON LOCK NUT	350259-00
4	1	1/2" x 2 3/4" BOLT	350100-00
5	4	1/2" LOCK WASHER	350309-00
6	2	1/2" NUT	350258-00
7	1	1/2" x 3 1/2" BOLT	350103-00
8	2	QUICK LINK	200008-00
9	2	SAFETY CABLE 8"	500646-08
10	4	1/4" x 1 1/2" x 2 1/2" BACKING PLATE	A-000134
11	2	1/4" x 2" x 2" BACKING PLATE	A-000188
12	1	DRIVER SIDE BRACE	B-000969
13	1	PASSENGER SIDE BRACE	B-000970
14	1	MAIN RECEIVER	C-001421
15	1	DRIVER SIDE ARM	C-001419
16	1	PASSENGER SIDE ARM	C-001420



BASEPLATE KIT INSTALLATION INSTRUCTIONS

KIT# 521558-1

03/04/08
KS

ROADMASTER, Inc. 6110 NE 127th Ave. Vancouver, WA 98682 1-800-669-9690 fax 360-735-9300 www.roadmasterinc.com

This is one of our EZ2 series brackets, which allows the visible front portion of the bracket to be easily removed from the front of the vehicle (Fig.A and Fig.B). The bracket kit consists of a main receiver brace, two side braces, two removable front braces and a hardware pack. The main receiver brace mounts to the frame rails. The side braces mount to the main receiver brace and the frame rails. The removable front braces install in the main receiver brace. Before starting the installation, lay out the kit components in order, as they will be used. This will give you a visual idea of how the components work, and will also confirm that everything is present and accounted for.



IMPORTANT: All baseplates **must** be assembled with all the bolts left loose for final adjustment and positioning (before tightening) unless otherwise instructed. All bolts **must** be torqued for proper strength. If more than one bolt is used per fastening point, the diagram may only show one. Use flat washers over all slotted holes and lock washers on all fasteners.

WARNING

Failure to heed these warnings or follow the installation instructions may result in a voided warranty, loss of towed vehicle, personal injury or death.

- Do not weld or modify this baseplate or its components. Welding or modification will void the warranty.
- Do not use this document as a basis to design/fabricate a baseplate, as it may not show all parts or structural components.
- We strongly recommend professional installation.
- If the towed vehicle has been in an accident, it must be properly repaired before attaching the baseplate. Do not install the baseplate if any structural frame damage is found.
- The installer must use all bolts and parts supplied. If running changes were made by the vehicle manufacturer after this kit was designed, some bolts or other fasteners may no longer be the correct size. It is the installer's responsibility to verify this kit is securely fastened to the vehicle.
- Use Loctite® Red on all bolts used to secure this baseplate. Torque all bolts to the specifications found at the end of these instructions. Do not over-torque the bolts or failure may occur.
- The installer must inspect the baseplate to ensure adequate clearance, particularly around hoses, air conditioner lines, radiators, etc. or non-warranty failure may result.
- Roadmaster manufactures many styles of baseplates. If your baseplate has removable arms, they must be removed before driving the vehicle, unless the arms can be pinned or padlocked in place. If not secured, the arms could vibrate out.
- Some motorhome chassis have such a tight turning radius that you can damage your motorhome, towed vehicle, tow bar or baseplate while turning sharply. Before getting on the road, test your turning radius in an empty parking lot. Turning too sharply could result in non-warranty damage to your towing system, motorhome and/or towed vehicle.
- Do not back up with the towed vehicle attached or non-warranty damage will occur to your towing system or vehicles.
- The safety cables must connect the towing vehicle to the towed vehicle frame to frame, with the cables crossed, with enough slack for sharp turns. See cable instructions for proper routing. Failure to do so will result in non-warranty damage and/or the loss of the towed vehicle.
- This kit is designed for use with ROADMASTER tow bars and ROADMASTER adapters only. Using this kit with other brands, without an approved ROADMASTER adapter, may result in non-warranty damage or injury.
- Receiver extensions and out-of-level towing situations of 3 inches or more. This can cause the system to swing much higher and lower, causing excessive strain on the tow bar, baseplate and frame. That can cause the towing system to fail, causing property damage, personal injury or even death. If you must use a receiver extension or drop hitch to tow, it will reduce your receiver's weight capacity by 1/3 to avoid damaging your system. Never use more than one extension and/or drop hitch, as this will void your warranty.
- Every 3,000 miles, the owner must inspect all mounting points for cracks or fatigue, and check the fasteners for proper torque, according to the bolt torque requirements chart on the last page of these instructions.
- The owner must follow the vehicle manufacturer's instructions to prepare the vehicle for towing. Failure to do so may cause severe damage to the vehicle.
- This baseplate is only warranted for the original installation. Installing a used baseplate on another vehicle is not recommended and will void the warranty.



BASEPLATE KIT INSTALLATION INSTRUCTIONS

KIT# 521558-1

03/04/08
KS

ROADMASTER, Inc. 6110 NE 127th Ave. Vancouver, WA 98682 1-800-669-9690 fax 360-735-9300 www.roadmasterinc.com

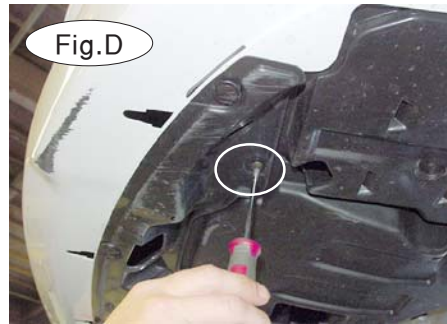
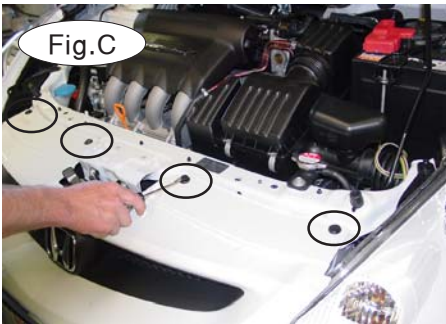

1. **Important:** please use all supplied bolts and parts and read all instructions carefully before beginning this installation. The majority of questions you may have can be answered within the text, and proper installation will ensure safe and secure travel. Now, begin the installation. Start by removing the four plastic fasteners that attach the fascia to the core support (Fig.C).

2. On each side, remove one Phillips head screw attaching the splash shield to the fascia (Fig.D).

3. On each side, remove one plastic fastener attaching the splash shield to the corner of the fascia (Fig.E).



4. Remove two more plastic fasteners attaching the splash shield to the radiator support (Fig.F).

5. One each side, remove one Phillips head screw attaching the fascia to the corner of the fender (Fig.G).

6. Now, remove the fascia by pulling out and forward on both corners of the fascia (Fig.H). Disconnect the fog lights, if the vehicle is so equipped.

7. Remove the plastic cover inside the engine compartment on the driver side, next to the headlight (Fig.I).



8. For both sides, remove the headlights by removing four 10mm (head) bolts per side. Three are located along the inside edge of the engine compartment (Fig.J). The fourth one is located on the outside rear corner (Fig.K). Remove both headlights and disconnect three electrical plugs per side.



BASEPLATE KIT INSTALLATION INSTRUCTIONS

KIT# 521558-1

03/04/08
KS

ROADMASTER, Inc. 6110 NE 127th Ave. Vancouver, WA 98682 1-800-669-9690 fax 360-735-9300 www.roadmasterinc.com



Fig.K

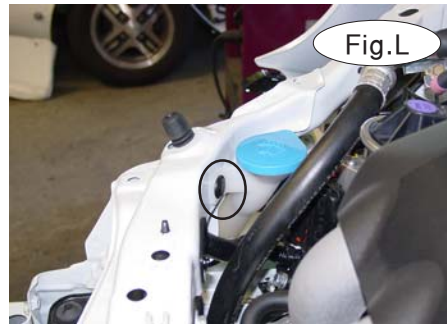

Fig.L

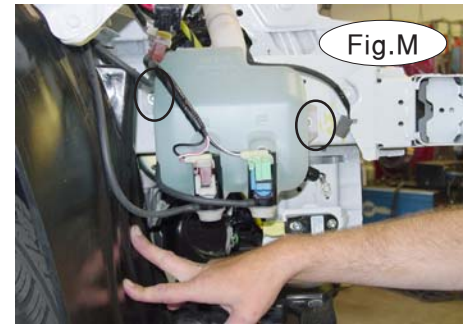

Fig.M

9. Temporarily remove the washer bottle by removing one plastic fastener from inside the engine compartment (Fig.L) and two 10mm bolts on the side of the frame rail (Fig.M).



Fig.N

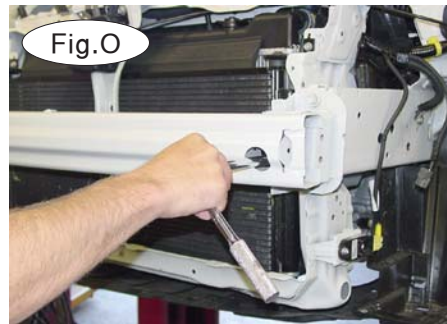

Fig.O

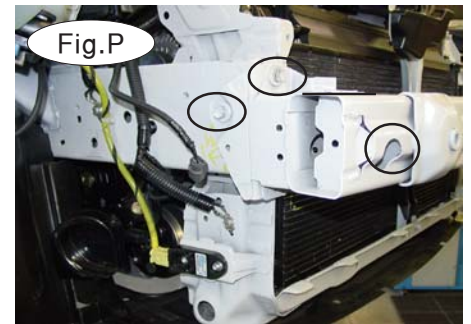

Fig.P

10. Using a wire or zip tie, attach the washer bottle to the side of the vehicle (Fig.N).

11. Remove the foam shock absorption pad from the bumper core by pulling forward on it. This will not be reinstalled.

12. Next, remove the bumper core by removing two 12mm bolts from the driver side (Fig.O) and three 12mm bolts from the passenger side (Fig.P). The bumper core will not be reinstalled. *Note:* retain the bumper core and attachment hardware in case the bracket is ever removed from the vehicle.

13. Place the main receiver brace over the ends of both frame rails (Fig.Q). Bolt into place using the bumper core bolts you removed in the previous step (Fig.R). *Note:* use thread lock on these bolts.

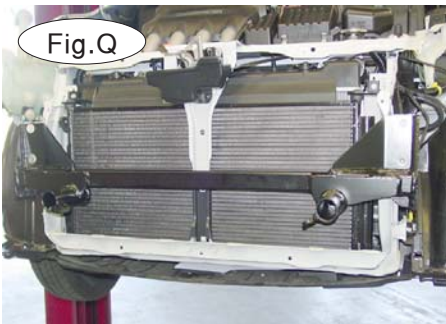

Fig.Q

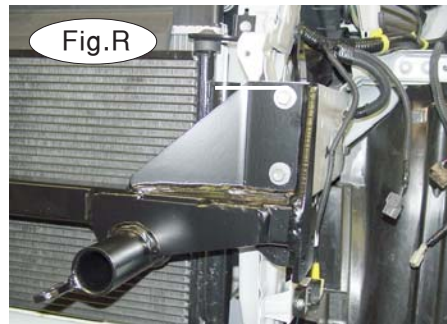

Fig.R



Fig.S

14. Starting on the driver side, measure 2 $\frac{3}{4}$ " from the end of the frame rail towards the rear of the vehicle and mark the location. Now, drill a hole direct center in the top of the frame rail at the 2 $\frac{3}{4}$ " mark (Fig.S).

15. Insert the supplied $\frac{1}{2}$ " x 5 $\frac{1}{2}$ " bolt through the $\frac{1}{4}$ " x 1 $\frac{1}{2}$ " x 2 $\frac{1}{2}$ " backing plate. Insert the bolt and backing plate through the hole you drilled in the frame rail in the previous step and into the existing hole in the bottom of the frame rail (Fig.T,U).



BASEPLATE KIT INSTALLATION INSTRUCTIONS

KIT# 521558-1

03/04/08
KS

ROADMASTER, Inc. 6110 NE 127th Ave. Vancouver, WA 98682 1-800-669-9690 fax 360-735-9300 www.roadmasterinc.com

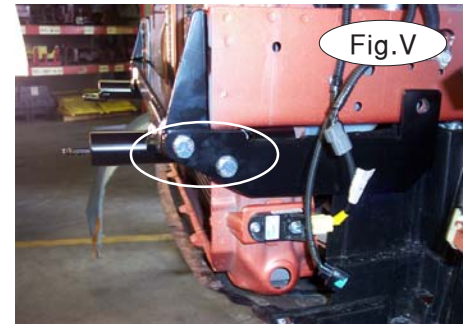

16. Set the side brace in place over the bolt from step 15 (Fig.U). Bolt through the top hole using a ½" x 1¼" bolt and lock washer. Use a ½" x 1¼" bolt, lock washer and nut on the bottom hole (Fig.V). Do not tighten.

17. Now, place a ½" nylock nut on the bolt you installed in step 15.

18. Before you can install the passenger side brace, relocate the horn to allow clearance for the side brace: Loosen the 12mm (head) bolt and rotate the horn about 20 degrees toward the front of the vehicle and re-tighten the bolt (Fig.W).

19. The ground connector next to the horn (Fig.X) needs to be temporarily disconnected. This will make installing the ½" flat washer and nylock nut for the passenger side easier.

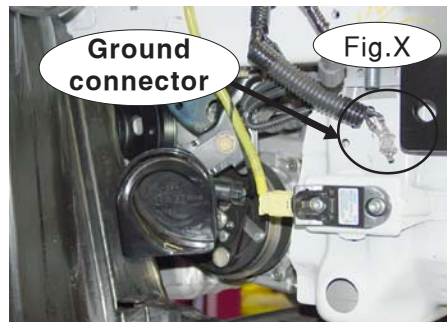
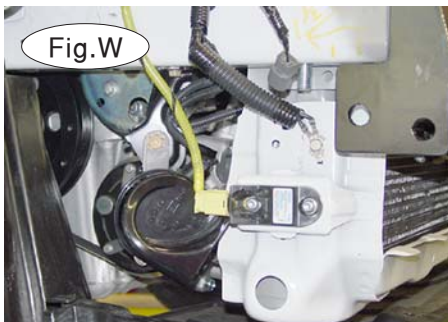

20. Repeat steps 14 through 18 for the passenger side of the vehicle. For step 16 on the passenger side, refer to Figure Y for correct placement.

21. Now, tighten all the bolts to the torque specifications listed at the end of these instructions.

22. Starting on the driver side, use the hole in the side brace as a template for drilling (Fig.Z). Before drilling, check to make certain you will not drill into any engine components on the other side. For the driver's side only, drill through the side of the frame rail and bolt through the main receiver brace, two spacer plates and the frame rail using the ½" x 3½" bolt, place the ¼" x 2" x 2½" backing plate on the inside of the frame rail and finish with a ½" nylock nut (Fig.AA). For the passenger side, drill through the side of the frame rail and bolt into place using a ½" x 2¾" bolt, ¼" x 1½" x 2½" backing plate and a ½" nyloc nut on the inside of the frame. Tighten to the torque specifications listed at the end of these instructions.





BASEPLATE KIT INSTALLATION INSTRUCTIONS

KIT# 521558-1

03/04/08
KS

ROADMASTER, Inc. 6110 NE 127th Ave. Vancouver, WA 98682 1-800-669-9690 fax 360-735-9300 www.roadmasterinc.com

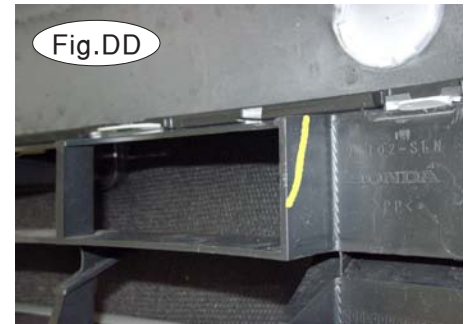
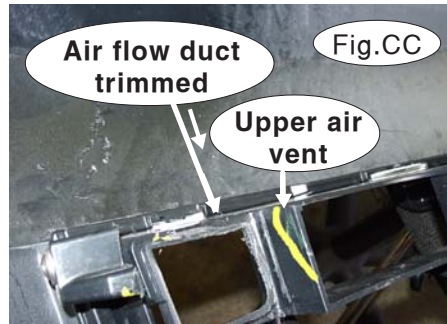
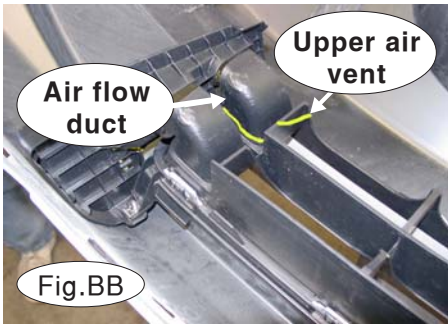

23. The back side of the fascia will need to be trimmed to allow clearance for the main receiver brace. On the driver's side, trim off the upper air flow duct (Fig.BB) and trim the upper air vent next to it (Fig.BB, CC). Use the yellow marker lines as guides for correct trimming.

24. For the passenger side trimming of the fascia, trim the upper air vent. Use the yellow marker line in Figure DD as a guide for correct trimming.

25. Reinstall the fascia, headlights and washer bottle, reversing steps 1 through 9

26. Insert the removable front braces into the main receiver brace, and twist them 90 degrees to lock. Attach the safety cables with the cable connectors (Q-Links) to the front of the receiver brace (Fig.EE). Attach the ends of the safety cables to the tow vehicle's safety cables and tow bar.



27. Install the tow bar to the mounting bracket according to the manufacturer's instructions.

BOLT TORQUE REQUIREMENTS

Note: The torque values represented below are intended as general guidelines. Torque requirements for specific applications may vary. Roadmaster does not warrant this information to be accurate for all applications and disclaims all liability for any claims or damages which may result from its use.

STANDARD BOLTS

Thread Size	Grade	Torque
5/16	5	13 ft./lb.
3/8	5	23 ft./lb.
7/16	5	37 ft./lb.
1/2	5	56 ft./lb.
5/8	5	150 ft./lb.

METRIC BOLTS

Thread Size	Grade	Plated / Unplated
8mm-1.0	8.8	20 ft./lb. 18 ft./lb.
8mm-1.25	8.8	19 ft./lb. 18 ft./lb.
10mm-1.25	8.8	38 ft./lb. 36 ft./lb.
10mm-1.5	8.8	37 ft./lb. 35 ft./lb.

METRIC BOLTS

Thread Size	Grade	Plated / Unplated
12mm-1.25	8.8	70 ft./lb. 65 ft./lb.
12mm-1.5	8.8	66 ft./lb. 61 ft./lb.
12mm-1.75	8.8	65 ft./lb. 60 ft./lb.
14mm-2.0	8.8	104 ft./lb. 97 ft./lb.

All illustrations and specifications contained herein are based on the latest information available at the time of publication approval. ROADMASTER, INC. reserves the right to make changes at any time without notice in material, specification and models or to discontinue models.