



BASEPLATE KIT INSTALLATION INSTRUCTIONS

KIT# 521629-1

08/20/10
KS

ROADMASTER, Inc. 6110 NE 127th Ave. Vancouver, WA 98682 1-800-669-9690 fax 360-735-9300 www.roadmasterinc.com

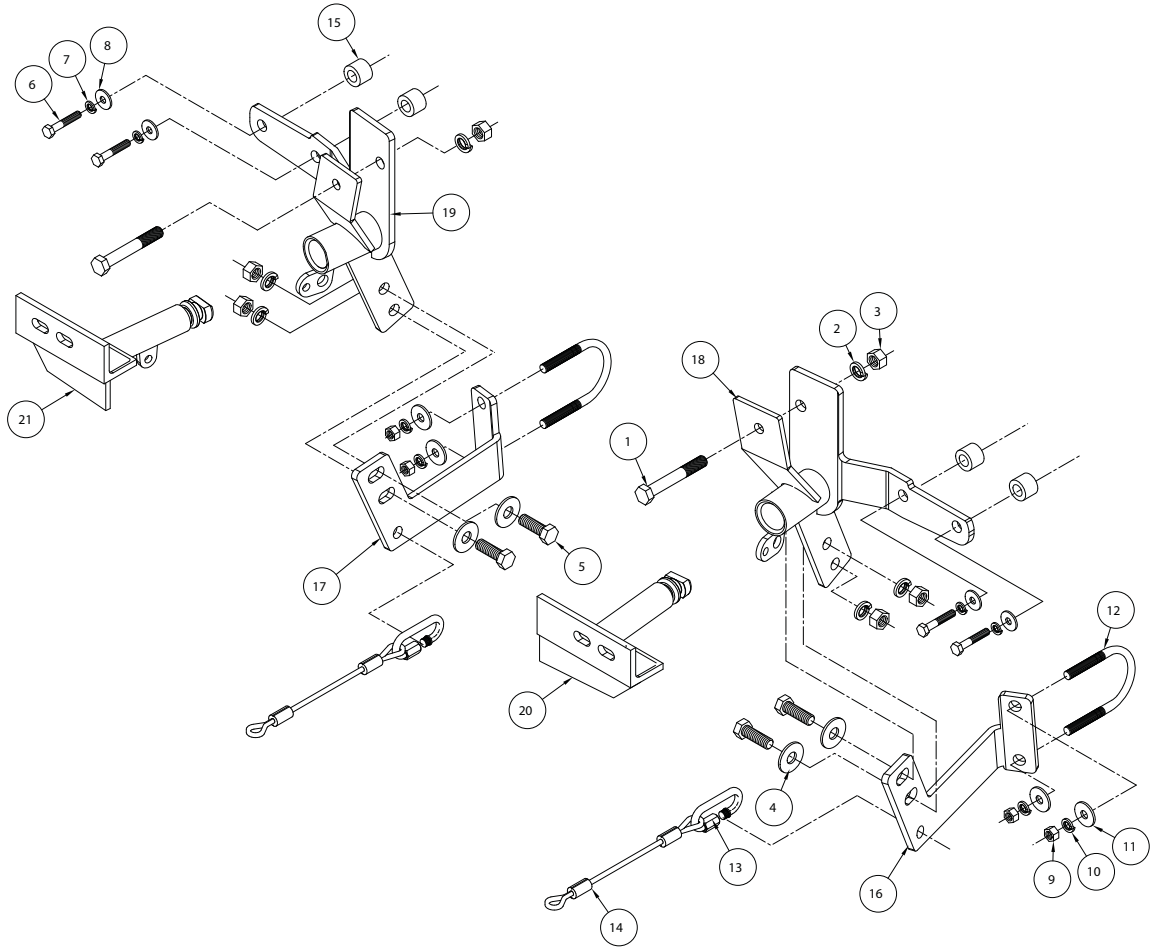

ITEM	QTY	NAME	MATERIAL
1	2	1/2" x 4" BOLT	350105-00
2	6	1/2" LOCK WASHER	350309-00
3	6	1/2" HEX NUT	350258-00
4	4	1/2" FLAT WASHER	350308-20
5	4	1/2" X 1 1/2" BOLT	350095-00
6	4	M8 X 1.25MM X 55MM BOLT	356006-00
7	4	8MM LOCK WASHER	355705-00
8	4	8MM FENDER WASHER	355702-00
9	4	3/8" HEX NUT	350254-00
10	4	3/8" LOCK WASHER	350305-00
11	4	3/8" FLAT WASHER	350304-00
12	2	3 5/8" X 2 1/2" X 3/8" U BOLT	357310-50
13	2	QUICK LINK	200008-00
14	2	8" SAFETY CABLE	650646-08
15	4	1" O.D. x 0.219 WALL x 1" PIPE SPACER	A-000028
16	1	DRIVER SIDE BRACE	B-001503
17	1	PASSENGER SIDE BRACE	B-001504
18	1	DRIVER SIDE RECEIVER	C-002051
19	1	PASSENGER SIDE RECEIVER	C-002052
20	1	DRIVER SIDE ARM	C-002053
21	1	PASSENGER SIDE ARM	C-002054



BASEPLATE KIT INSTALLATION INSTRUCTIONS

KIT# 521629-1

08/20/10
KS

ROADMASTER, Inc. 6110 NE 127th Ave. Vancouver, WA 98682 1-800-669-9690 fax 360-735-9300 www.roadmasterinc.com

This is one of our EZ2 series brackets, which allows the visible front portion of the bracket to be easily removed from the front of the vehicle (Fig.A and Fig.B). The bracket consists of two main receiver braces, two lower braces, two removable front braces, and a hardware pack.

The main receiver braces mount to the frame rails and the bumper core. The lower braces mount to the frame cross bar and the main receiver braces. The removable front braces install in the main receiver braces.

Before starting the installation, lay out the kit components in order, as they will be used. This will give you a visual idea of how the components work, and will also confirm that everything is present and accounted for.



Fig.A



Fig.B

IMPORTANT: All baseplates **must** be assembled with all the bolts left loose for final adjustment and positioning (before tightening) unless otherwise instructed. All bolts **must** be torqued for proper strength. If more than one bolt is used per fastening point, the diagram may only show one. Use flat washers over all slotted holes and lock washers on all fasteners.

WARNING

Failure to heed these warnings or follow the installation instructions may result in a voided warranty, loss of towed vehicle, personal injury or death.

- Do not weld or modify this baseplate or its components. Welding or modification will void the warranty.
- Do not use this document as a basis to design/fabricate a baseplate, as it may not show all parts or structural components.
- We strongly recommend professional installation.
- If the towed vehicle has been in an accident, it must be properly repaired before attaching the baseplate. Do not install the baseplate if any structural frame damage is found.
- The installer must use all bolts and parts supplied. If running changes were made by the vehicle manufacturer after this kit was designed, some bolts or other fasteners may no longer be the correct size. It is the installer's responsibility to verify this kit is securely fastened to the vehicle.
- Use Loctite® Red on all bolts used to secure this baseplate. Torque all bolts to the specifications found at the end of these instructions. Do not over-torque the bolts or failure may occur.
- The installer must inspect the baseplate to ensure adequate clearance, particularly around hoses, air conditioner lines, radiators, etc. or non-warranty failure may result.
- Roadmaster manufactures many styles of baseplates. If your baseplate has removable arms, they must be removed before driving the vehicle, unless the arms can be pinned or padlocked in place. If not secured, the arms could vibrate out.
- Some motorhome chassis have such a tight turning radius that you can damage your motorhome, towed vehicle, tow bar or baseplate while turning sharply. Before getting on the road, test your turning radius in an empty parking lot. Turning too sharply could result in non-warranty damage to your towing system, motorhome and/or towed vehicle.
- Do not back up with the towed vehicle attached or non-warranty damage will occur to your towing system or vehicles.
- The safety cables must connect the towing vehicle to the towed vehicle frame to frame, with the cables crossed, with enough slack for sharp turns. See cable instructions for proper routing. Failure to do so will result in non-warranty damage and/or the loss of the towed vehicle.
- This kit is designed for use with ROADMASTER tow bars and ROADMASTER adapters only. Using this kit with other brands, without an approved ROADMASTER adapter, may result in non-warranty damage or injury.
- Receiver extensions and out-of-level towing situations of 3 inches or more. This can cause the system to swing much higher and lower, causing excessive strain on the tow bar, baseplate and frame. That can cause the towing system to fail, causing property damage, personal injury or even death. If you must use a receiver extension or drop hitch to tow, it will reduce your receiver's weight capacity by 1/3 to avoid damaging your system. Never use more than one extension and/or drop hitch, as this will void your warranty.
- Every 3,000 miles, the owner must inspect all mounting points for cracks or fatigue, and check the fasteners for proper torque, according to the bolt torque requirements chart on the last page of these instructions.
- The owner must follow the vehicle manufacturer's instructions to prepare the vehicle for towing. Failure to do so may cause severe damage to the vehicle.
- This baseplate is only warranted for the original installation. Installing a used baseplate on another vehicle is not recommended and will void the warranty.



BASEPLATE KIT INSTALLATION INSTRUCTIONS

KIT# 521629-1

08/20/10
KS

ROADMASTER, Inc. 6110 NE 127th Ave. Vancouver, WA 98682 1-800-669-9690 fax 360-735-9300 www.roadmasterinc.com



1. **Important:** please use all supplied bolts and parts and read all instructions carefully before beginning this installation. The majority of questions you may have can be answered within the text, and proper installation will ensure safe and secure travel. Now, begin the installation by removing four plastic fasteners attaching the top of the fascia to the core support (Fig.C).

2. On each side, remove one Phillips screw attaching the corner of the fascia to the fender (Fig.D).



3. On each side, remove three plastic fasteners attaching the fender line and splash shield to the bottom of the fascia (Fig.E).

4. Remove ten 10mm (head) screws attaching the three lower splash shields to the subframe and core support (Fig.F).

5. Disconnect the fog lights, if the vehicle is so equipped.

6. Pull out and forward on the corners of the fascia to remove it (Fig.G).

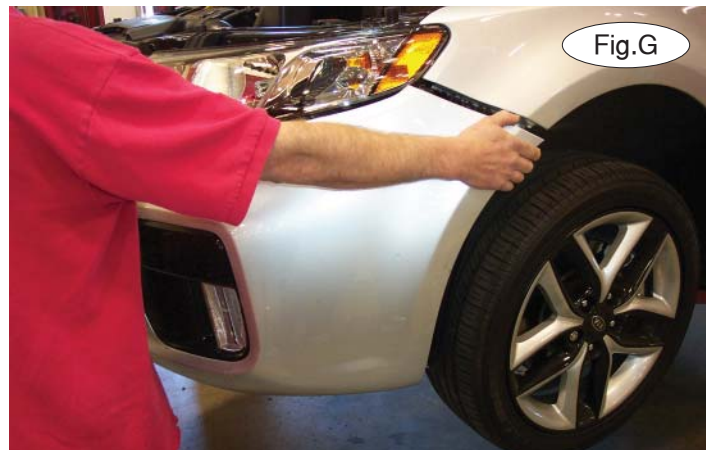



BASEPLATE KIT INSTALLATION INSTRUCTIONS

KIT# 521629-1

08/20/10
KS

ROADMASTER, Inc. 6110 NE 127th Ave. Vancouver, WA 98682 1-800-669-9690 fax 360-735-9300 www.roadmasterinc.com



7. On each side, trim the air deflector using the white line in Figure H (passenger side) as a guide.
8. On each side, remove the two lower 12mm (head) bolts attaching the bumper core to the frame rails (Fig.I).

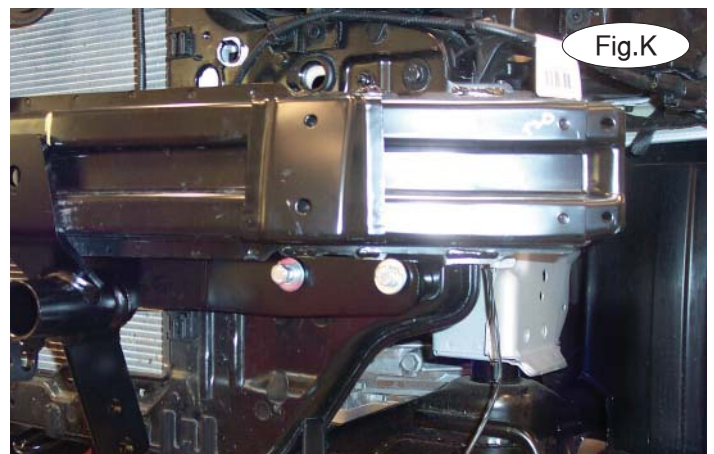

9. Working on the driver's side, place one of the supplied 8mm lock washers and 8mm fender washers over one of the supplied 8mm x 1.25 x 55mm bolts. Bolt through the inside mounting point of the side brace, then place a 1" x 1" spacer over the back side of the bolt. Rotate the brace up over the bumper core (Fig.J).

10. Now, place another 1" x 1" spacer between the outer mounting point and the outside bumper core mounting point. Using one of the supplied 8mm x 1.25 x 55mm bolts, an 8mm lock washer and 8mm fender washer, bolt through the main receiver brace, pipe spacer and into the end of the frame rail (Fig.K).

11. Adjust the height of the main receiver brace so there is a $\frac{3}{4}$ " gap between the main receiver brace and the bumper core (Fig.L).

12. Now, torque the bumper core mounting bolts to the bolt torque requirements found at the end of these instructions.

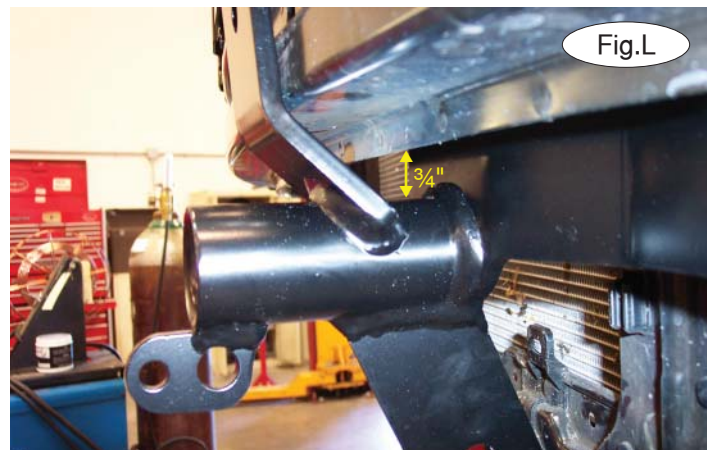



BASEPLATE KIT INSTALLATION INSTRUCTIONS

KIT# 521629-1

08/20/10
KS

ROADMASTER, Inc. 6110 NE 127th Ave. Vancouver, WA 98682 1-800-669-9690 fax 360-735-9300 www.roadmasterinc.com

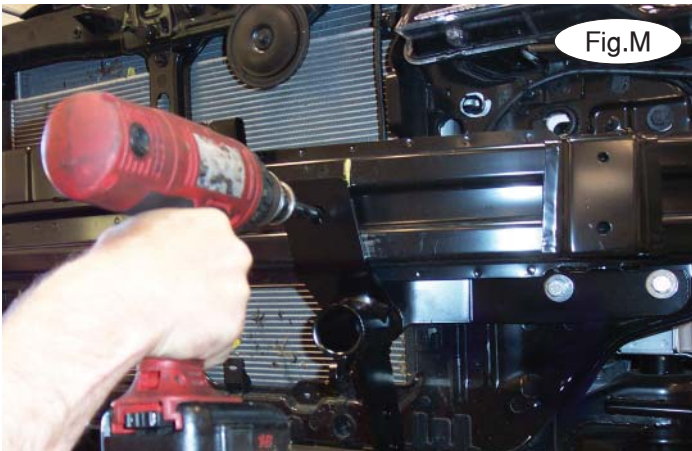

Fig.M



Fig.N

13. Using the upper mounting point of the main receiver brace as a template, drill a $\frac{1}{2}$ " hole through the face of the bumper core (Fig.M). *Note:* use a piece of metal as a buffer between the drill bit and the engine components.

14. Place a $\frac{1}{2}$ " x 4" bolt through the upper mounting point, bumper core and the rear of the main receiver brace. Finish with a $\frac{1}{2}$ " lock washer and nut (Fig.N).

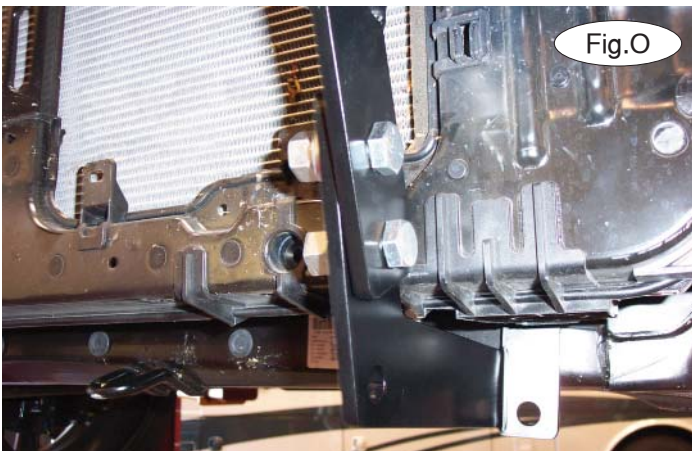

Fig.O

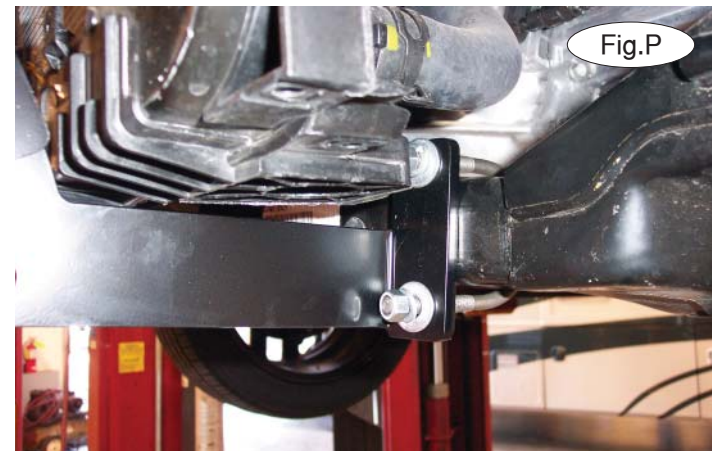

Fig.P

15. Repeat steps 9 through 13 for the passenger side. Torque the bolts to the bolt torque requirements found at the end of these instructions.

16. Working on the driver's side, and using two of the supplied $\frac{1}{2}$ " x $1\frac{1}{2}$ " bolts, bolt through the lower brace and main receiver brace, and finish with a $\frac{1}{2}$ " flat washer, lock washer and nut (Fig.O). *Note:* the flat washer should be over the slotted hole.

17. Place one of the supplied $3\text{-}5/8$ " x $2\frac{1}{2}$ " x $3/8$ " U bolts over the back of the subframe and through the rear of the lower brace (Fig.P). Finish with two $3/8$ " lock washers, flat washers and nuts.

18. Tighten the bolts to the bolt torque requirements found at the end of these instructions.

19. Repeat steps 16 through 18 for the passenger side. *Note:* due to the shape of the subframe on the passenger side, it may be necessary to put the flat washer and nut on the U-bolt and tighten it to allow enough threads for the lock washer to fit.



BASEPLATE KIT INSTALLATION INSTRUCTIONS

KIT# 521629-1

08/20/10
KS

ROADMASTER, Inc. 6110 NE 127th Ave. Vancouver, WA 98682 1-800-669-9690 fax 360-735-9300 www.roadmasterinc.com

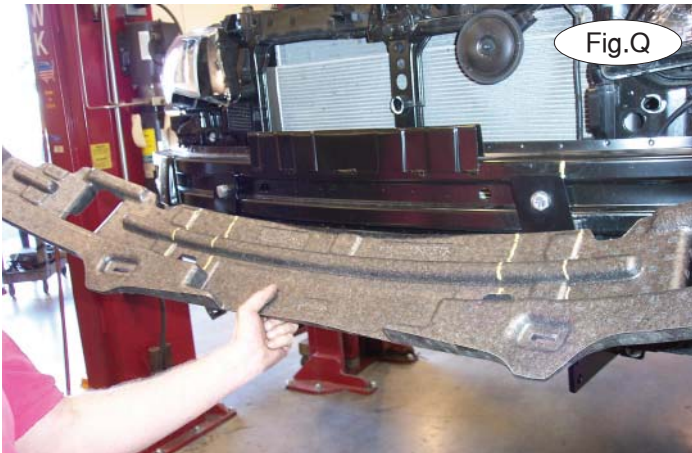

20. Remove the two metal clips attaching the shock absorption pad to the back of the fascia. Hold it in place over the bumper core and mark it for trimming to allow clearance for the main receiver braces. Use the yellow lines in Figure Q as a guide for trimming. Now, reinstall the shock absorption pad.

21. Hold the fascia in place over the main receiver braces and mark it for trimming. Use a 2" hole saw to trim the fascia so it fits over the receiver (Fig.R).



22. Reinstall the fascia by reversing steps 4 through 6.

23. Trim the rear splash shields to allow clearance for the U bolts, then reinstall the splash shield. Figure S shows the reinstalled splash shield after trimming.

22. Finish reinstalling the fascia by reversing steps 1 through 3.

23. Trim the center splash shield into three pieces to allow clearance for the rear braces. Reinstall the pieces to the outside and inside of the rear braces. Figure T shows the completed trimming and reinstallation.



BASEPLATE KIT INSTALLATION INSTRUCTIONS

KIT# 521629-1

08/20/10
KS

ROADMASTER, Inc. 6110 NE 127th Ave. Vancouver, WA 98682 1-800-669-9690 fax 360-735-9300 www.roadmasterinc.com

24. Insert the removable front bracket arms into the front receiver braces, and twist each one 90 degrees to lock.
25. Attach the 8" safety cables with the cable connectors (Q-Links) to the front of the receiver braces (Fig.U).
26. Attach the ends of the safety cables to the tow vehicle's safety cables.
27. Install the tow bar to the mounting bracket according to the manufacturer's instructions.



Fig.U

BOLT TORQUE REQUIREMENTS

Note: The torque values represented below are intended as general guidelines. Torque requirements for specific applications may vary. Roadmaster does not warrant this information to be accurate for all applications and disclaims all liability for any claims or damages which may result from its use.

STANDARD BOLTS

Thread Size	Grade	Torque
5/16.....	5.....	13 ft./lb.
3/8.....	5.....	23 ft./lb.
7/16.....	5.....	37 ft./lb.
1/2.....	5.....	56 ft./lb.
5/8.....	5.....	150 ft./lb.

METRIC BOLTS

Thread Size	Grade	Plated / Unplated
8mm-1.0	8.8	20 ft./lb. 18 ft./lb.
8mm-1.25	8.8	19 ft./lb. 18 ft./lb.
10mm-1.25	8.8	38 ft./lb. 36 ft./lb.
10mm-1.5	8.8	37 ft./lb. 35 ft./lb.

METRIC BOLTS

Thread Size	Grade	Plated / Unplated
12mm-1.25	8.8	70 ft./lb. 65 ft./lb.
12mm-1.5	8.8	66 ft./lb. 61 ft./lb.
12mm-1.75	8.8	65 ft./lb. 60 ft./lb.
14mm-2.0	8.8	104 ft./lb. 97 ft./lb.

All illustrations and specifications contained herein are based on the latest information available at the time of publication approval. ROADMASTER, INC. reserves the right to make changes at any time without notice in material, specification and models or to discontinue models.