



BASEPLATE KIT INSTALLATION INSTRUCTIONS

KIT# 52345-1

06/17/05
RV

ROADMASTER, Inc. 6110 NE 127th Ave. Vancouver, WA 98682 1-800-669-9690 fax 360-735-9300 www.roadmasterinc.com

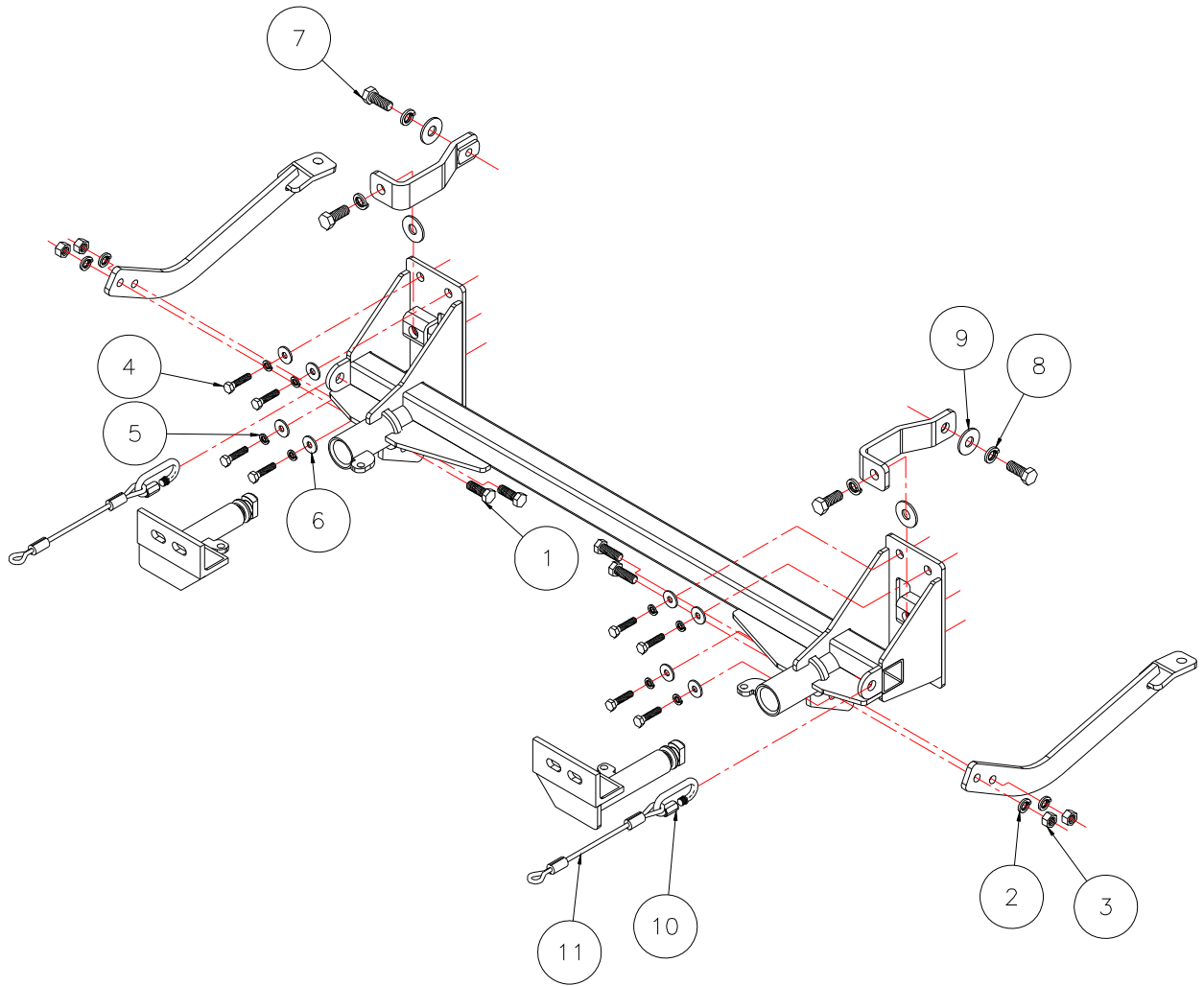

Item	Qty	Length	Width	Name	Material
1	4	1 1/4"	7/16"	7/16" x 1 1/4" BOLT	350073-00
2	4		7/16"	LOCK WASHER	350307-00
3	4		7/16"	NUT	350256-00
4	8	35mm	8mm	8mm x 1.25 x 35mm BOLT	356002-00
5	8		8mm	LOCK WASHER	355705-00
6	8		8mm	FENDER WASHER	355702-00
7	4	1 1/4"	1/2"	1/2" x 1 1/4" BOLT	350094-10
8	4		1/2"	LOCK WASHER	350309-00
9	4		1/2"	FLAT WASHER	350308-20
10	2			CABLE CONNECTOR	200008-00
11	2	8"		SAFETY CABLE	500646-08



BASEPLATE KIT INSTALLATION INSTRUCTIONS

KIT# 52345-1

06/17/05
RV

ROADMASTER, Inc. 6110 NE 127th Ave. Vancouver, WA 98682 1-800-669-9690 fax 360-735-9300 www.roadmasterinc.com

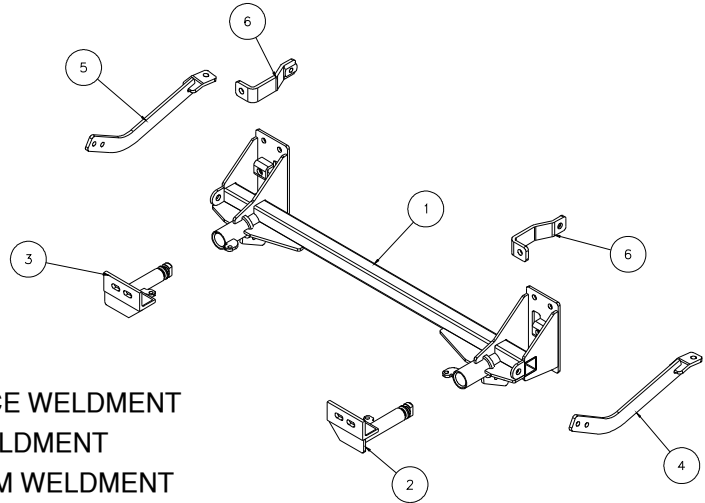

Item	Qty.	Part #	Description
1	1	C-001264	MAIN RECEIVER BRACE WELDMENT
2	1	C-001265	DRIVER SIDE ARM WELDMENT
3	1	C-001266	PASSENGER SIDE ARM WELDMENT
4	1	C-001267	DRIVER SIDE REAR BRACE WELDMENT
5	1	C-001268	PASSENGER SIDE REAR BRACE WELDMENT
6	2	C-001269	UPPER REAR BRACE WELDMENT

IMPORTANT: All baseplates **must** be assembled with all the bolts left loose for final adjustment and positioning (before tightening) unless otherwise instructed. All bolts **must** be torqued for proper strength. If more than one bolt is used per fastening point, the diagram may only show one. Use flat washers over all slotted holes and lock washers on all fasteners.

WARNING

Failure to heed these warnings or follow the installation instructions may result in a voided warranty, loss of towed vehicle, personal injury or death.

- Do not weld or modify this baseplate or its components. Welding or modification will void the warranty.
- Do not use this document as a basis to design/fabricate a baseplate, as it may not show all parts or structural components.
- We strongly recommend professional installation.
- If the towed vehicle has been in an accident, it must be properly repaired before attaching the baseplate. Do not install the baseplate if any structural frame damage is found.
- The installer must use all bolts and parts supplied. If running changes were made by the vehicle manufacturer after this kit was designed, some bolts or other fasteners may no longer be the correct size. It is the installer's responsibility to verify this kit is securely fastened to the vehicle.
- Use Loctite® Red on all bolts used to secure this baseplate. Torque all bolts to the specifications found at the end of these instructions. Do not over-torque the bolts or failure may occur.
- The installer must inspect the baseplate to ensure adequate clearance, particularly around hoses, air conditioner lines, radiators, etc. or non-warranty failure may result.
- Roadmaster manufactures many styles of baseplates. If your baseplate has removable arms, they must be removed before driving the vehicle, unless the arms can be pinned or padlocked in place. If not secured, the arms could vibrate out.
- Some motorhome chassis have such a tight turning radius that you can damage your motorhome, towed vehicle, tow bar or baseplate while turning sharply. Before getting on the road, test your turning radius in an empty parking lot. Turning too sharply could

result in non-warranty damage to your towing system, motorhome and/or towed vehicle.

- Do not back up with the towed vehicle attached or non-warranty damage will occur to your towing system or vehicles.
- The safety cables must connect the towing vehicle to the towed vehicle frame to frame, with the cables crossed, with enough slack for sharp turns. See cable instructions for proper routing. Failure to do so will result in non-warranty damage and/or the loss of the towed vehicle.
- This kit is designed for use with ROADMASTER tow bars and ROADMASTER adapters only. Using this kit with other brands, without an approved ROADMASTER adapter, may result in non-warranty damage or injury.
- Receiver extensions and out-of-level towing situations of 3 inches or more. This can cause the system to swing much higher and lower, causing excessive strain on the tow bar, baseplate and frame. That can cause the towing system to fail, causing property damage, personal injury or even death. If you must use a receiver extension or drop hitch to tow, it will reduce your receiver's weight capacity by 1/3 to avoid damaging your system. Never use more than one extension and/or drop hitch, as this will void your warranty.
- Every 3,000 miles, the owner must inspect all mounting points for cracks or fatigue, and check the fasteners for proper torque, according to the bolt torque requirements chart on the last page of these instructions.
- The owner must follow the vehicle manufacturer's instructions to prepare the vehicle for towing. Failure to do so may cause severe damage to the vehicle.
- This baseplate is only warranted for the original installation. Installing a used baseplate on another vehicle is not recommended and will void the warranty.



BASEPLATE KIT INSTALLATION INSTRUCTIONS

KIT# 52345-1

06/17/05
RV

ROADMASTER, Inc. 6110 NE 127th Ave. Vancouver, WA 98682 1-800-669-9690 fax 360-735-9300 www.roadmasterinc.com

This is one of our EZ series brackets, which allows the visible front portion of the brackets to be easily removed from the front of the vehicle (Fig.A and Fig.B). The bracket consists of a main receiver brace, two center braces, two rear braces, two removable front braces and a hardware pack.

The main receiver brace mounts to the frame rails; the center and rear braces mount to the main receiver brace and the frame rails; and the removable front braces install in the main receiver brace.

Before starting the installation, lay out the kit components in order, as they will be used. This will give you a visual idea of how the components work, and will also confirm that everything is present and accounted for.

1. Important: please use all supplied bolts and parts and read all instructions carefully before beginning this installation. The majority of questions you may have can be answered within the text, and proper installation will ensure safe and secure travel. Now, begin the installation.

Start by removing six plastic fasteners across the top of the fascia, holding the fascia to the core support (Fig.C).

2. Next, on each side, remove three plastic fasteners holding the fender liner to the fascia (Fig.D).

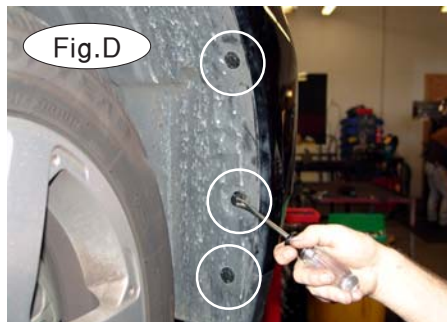

3. Now, remove (18) 10mm (head) screws and one plastic fastener (Fig.E) holding the splash shield and the fender liner to the fascia, the subframe, and the core support. Remove the splash shield (Fig.F).

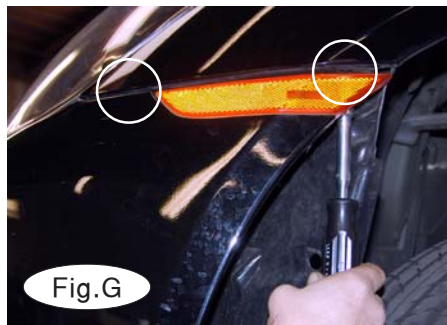

4. At both front wheel wells, pull back on the fender liner to gain access to the two 10mm bolts holding the fascia to the fender liner (Fig.G), and remove them.

5. On each side, unplug the side marker lights (Fig.H), as well as the fog lights, if the vehicle is so equipped.



BASEPLATE KIT INSTALLATION INSTRUCTIONS

KIT# 52345-1

06/17/05
RV

ROADMASTER, Inc. 6110 NE 127th Ave. Vancouver, WA 98682 1-800-669-9690 fax 360-735-9300 www.roadmasterinc.com



Fig.I



Fig.J

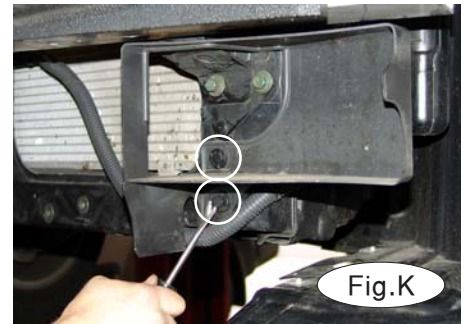

Fig.K

6. Pull forward on the fascia to remove it (Fig.I).

7. On each side, remove the upper air deflectors (Fig.J). The upper air deflectors are glued to the bumper core – pull up to remove them.

8. Remove the lower air deflectors on each side by removing three plastic fasteners (Fig.K) – two on the lower front, and one on the back.

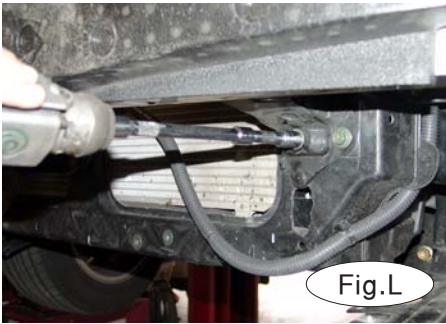

Fig.L



Fig.M



Fig.N

9. Remove eight 13mm (head) bolts across the bumper support, holding the bumper support to the core support (Fig.L).

10. On each side, remove two plastic fasteners holding the bumper to the core support (Fig.M). Then, remove the bumper core (Fig.N) and discard it – the main receiver brace will replace the bumper core.

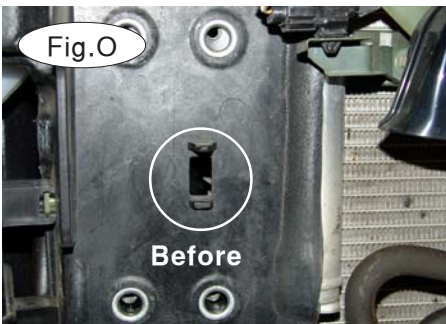

Fig.O

Before

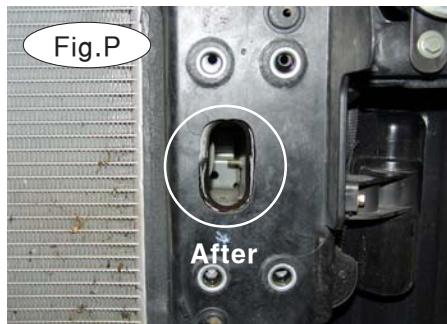

Fig.P

After

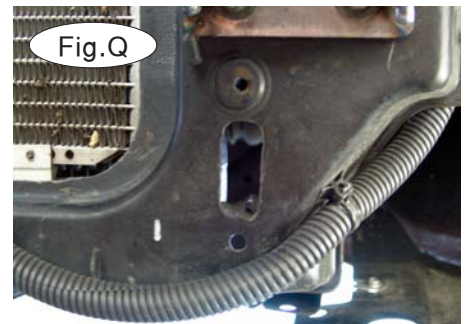

Fig.Q

11. On each side, enlarge the existing hole in the core support (Fig.O and Fig.P), and cut an additional hole in the core support (Fig.Q).



BASEPLATE KIT INSTALLATION INSTRUCTIONS

KIT# 52345-1

06/17/05
RV

ROADMASTER, Inc. 6110 NE 127th Ave. Vancouver, WA 98682 1-800-669-9690 fax 360-735-9300 www.roadmasterinc.com

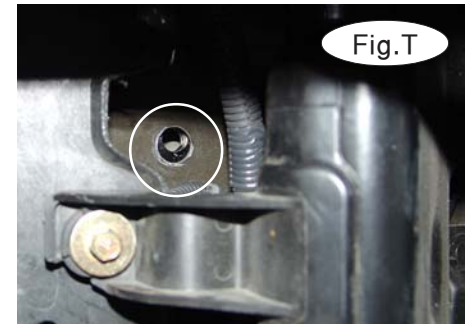
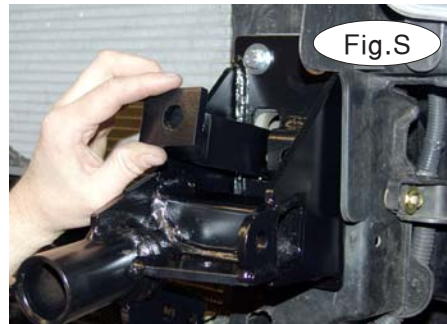
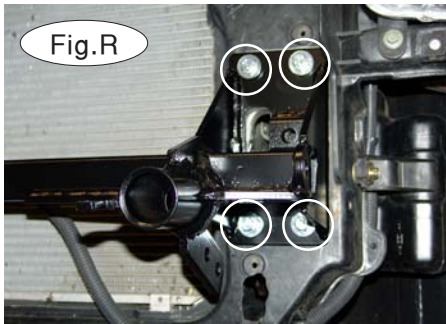

12. Position the main receiver brace over the bumper core so that the four pre-drilled holes at each end of the brace align over the existing bumper core weld nuts. Bolt into place (Fig.R) at each end with four of the supplied 8mm x 1.25 x 35mm bolts, fender washers and lock washers, into the existing bumper core weld nuts. Finger-tighten only at this time.

13. Now, attach one of the center braces to the frame rail – first, insert the center brace through the hole in the main receiver brace (Fig.S). Align the pre-drilled hole in the center brace to the existing hole in the frame rail (Fig.T).

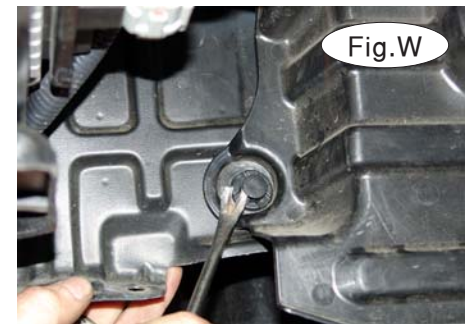
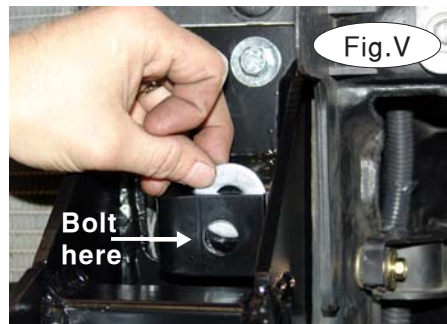

14. From the outside of the frame rail, bolt the center brace to the frame rail (Fig.U) with one of the supplied $\frac{1}{2}$ " x $1\frac{1}{4}$ " bolts, lock washers and flat washers, into the weld nut on the center brace. Finger-tighten only at this time.

15. Now, attach the center brace to the main receiver brace – the center brace must sit flush against the main receiver brace. If there is slack between the braces, insert one of the optional spacers between the main brace and the center brace (Fig.V). Then, bolt the center brace to the main brace (Fig.V), with one of the supplied $\frac{1}{2}$ " x $1\frac{1}{4}$ " bolts and lock washers, into the weld nut on the main brace. Finger-tighten only at this time. Repeat for the other side.

16. Remove a plastic fastener on the lower front passenger side splash shield (Fig.W), covering the sway bar mount, and move the splash shield to one side

17. Then, remove the front outside nut (13mm head) holding the sway bar mount to the frame rail (Fig.X).

18. On the driver side, remove the front outside bolt (13mm head) holding the sway bar mount to the frame rail.

19. From the rear, insert the driver side rear brace through the lower access hole in the core support (Fig.Y).

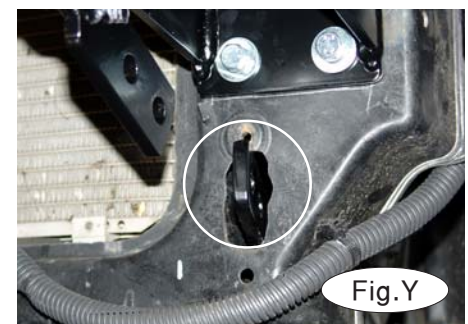
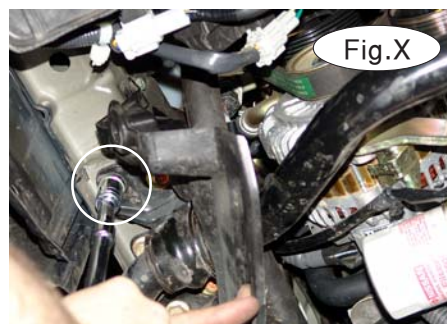



BASEPLATE KIT INSTALLATION INSTRUCTIONS

KIT# 52345-1

06/17/05
RV

ROADMASTER, Inc. 6110 NE 127th Ave. Vancouver, WA 98682 1-800-669-9690 fax 360-735-9300 www.roadmasterinc.com

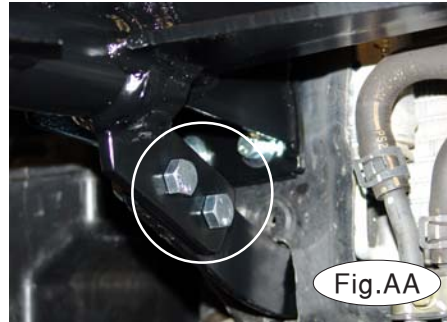
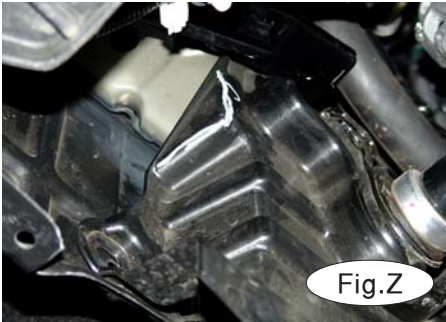

20. At the back, attach the driver side rear brace to the sway bar mount with the factory bolt you removed in step 18. Finger-tighten only at this time.
21. Before attaching the passenger side rear brace, trim a small portion of the passenger side splash shield covering the sway bar mount. Use the white marker line in Figure Z as a reference. Trim the splash shield and test-fit the rear brace, until you have trimmed enough to accommodate the rear brace.
22. At the back, attach the passenger side rear brace to the sway bar mount with the factory nut you removed in step 17. Finger-tighten only at this time.
23. Now, bolt both rear braces to the main receiver brace, using two of the supplied 7/16" x 1 1/4" bolts, lock washers and nuts on each side (Fig.AA).
24. Check to make sure the main receiver brace is level (Fig.BB), and then torque all bolts to the specifications at the bottom of these instructions.
25. Before reattaching the components you removed earlier, trim two sections from each lower air deflector. Use Figure CC as a reference. Trim a small portion and test fit each air deflector, until you have trimmed enough away to accommodate the rear braces.
26. Now, reattach the lower air deflectors, the upper air deflectors, the splash shield and the fascia, reversing steps 1 through 9. Note: the upper air deflectors can either be discarded, or glued to the side edge of the core support (Fig.DD).





BASEPLATE KIT INSTALLATION INSTRUCTIONS

KIT# 52345-1

06/17/05
RV

ROADMASTER, Inc. 6110 NE 127th Ave. Vancouver, WA 98682 1-800-669-9690 fax 360-735-9300 www.roadmasterinc.com

- 27. Insert the front braces into the main receiver braces and twist 90 degrees to lock. Attach the safety cables with the cable connectors (Q-Links) to the front of the receiver braces (Fig.EE). Attach the ends of the safety cables to the tow vehicle's safety cables and tow bar.
- 28. Install the tow bar to the mounting bracket according to the manufacturer's instructions.



BOLT TORQUE REQUIREMENTS

Note: The torque values represented below are intended as general guidelines. Torque requirements for specific applications may vary. Roadmaster does not warrant this information to be accurate for all applications and disclaims all liability for any claims or damages which may result from its use.

STANDARD BOLTS

Thread Size	Grade	Torque
5/16	5	13 ft./lb.
3/8	5	23 ft./lb.
7/16	5	37 ft./lb.
1/2	5	56 ft./lb.
5/8	5	150 ft./lb.

METRIC BOLTS

Thread Size	Grade	Plated / Unplated
8mm-1.0	8.8	20 ft./lb. 18 ft./lb.
8mm-1.25	8.8	19 ft./lb. 18 ft./lb.
10mm-1.25	8.8	38 ft./lb. 36 ft./lb.
10mm-1.5	8.8	37 ft./lb. 35 ft./lb.

METRIC BOLTS

Thread Size	Grade	Plated / Unplated
12mm-1.25	8.8	70 ft./lb. 65 ft./lb.
12mm-1.5	8.8	66 ft./lb. 61 ft./lb.
12mm-1.75	8.8	65 ft./lb. 60 ft./lb.
14mm-2.0	8.8	104 ft./lb. 97 ft./lb.

All illustrations and specifications contained herein are based on the latest information available at the time of publication approval. ROADMASTER, INC. reserves the right to make changes at any time without notice in material, specification and models or to discontinue models.