



BASEPLATE KIT INSTALLATION INSTRUCTIONS

KIT# 822-3

8/23/04

ROADMASTER, Inc. 6110 NE 127th Ave. Vancouver, WA 98682 360-896-0407 fax 360-735-9300 www.roadmasterinc.com

Important

Note: this bracket will not accommodate the Guardian rock shield, some models of the Tow Defender, Stowaway or the StowMaster and StowMaster All Terrain tow bars.

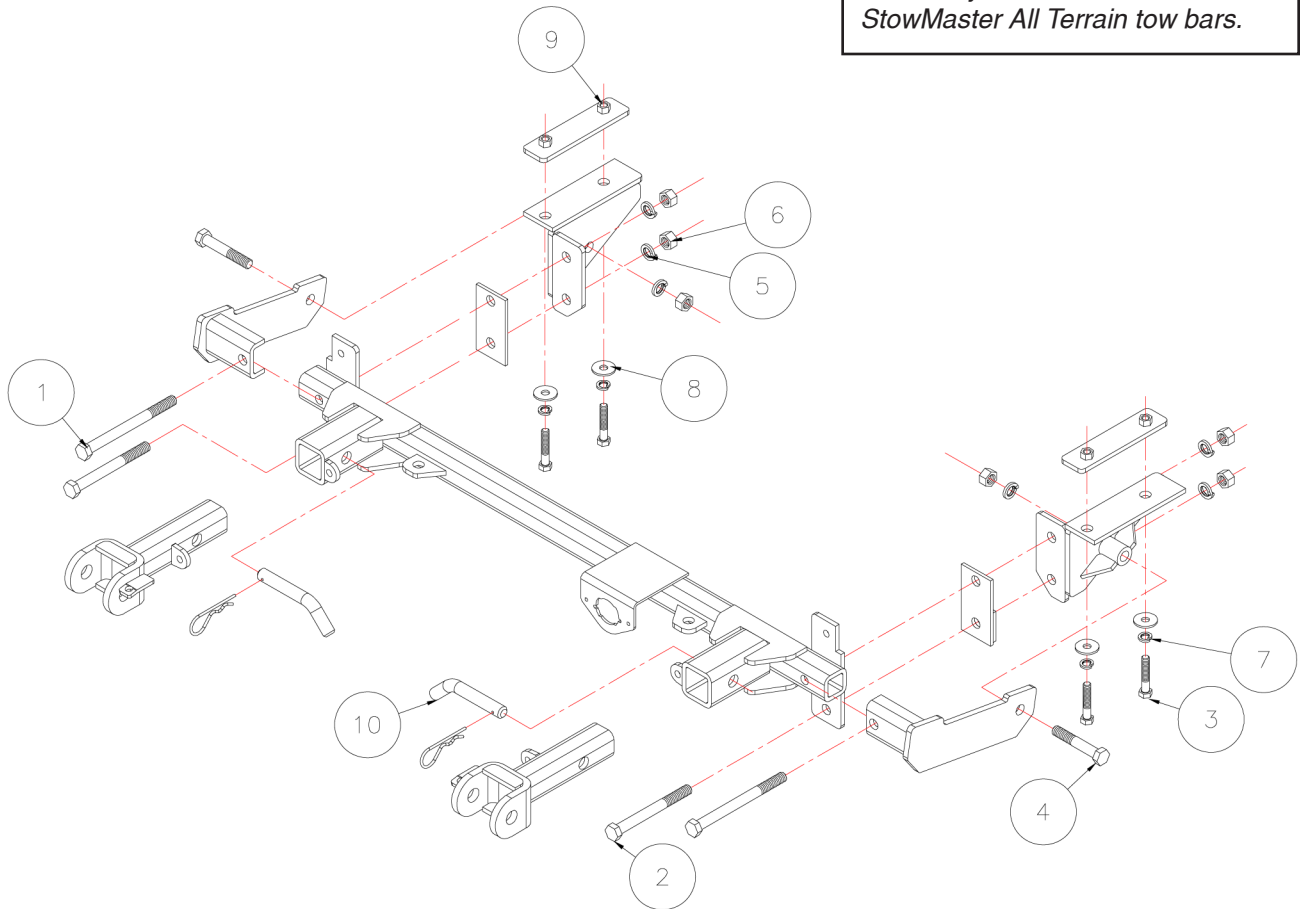

Item	Qty.	Length	Width	Description	Part #
1.....	2	6"	1/2"	1/2" x 6" BOLT	350109-00
2.....	2	4"	1/2"	1/2" x 4" BOLT	350105-00
3.....	4	2"	3/8"	3/8" x 2" BOLT	350059-00
4.....	2	3"	1/2"	1/2" x 3" BOLT	350123-00
5.....	6		1/2"	LOCK WASHER	350309-00
6.....	6		1/2"	NUT	350258-00
7.....	4		3/8"	LOCK WASHER	350305-00
8.....	4		3/8"	FLAT WASHER	350304-50
9.....	4		3/8"	NUT	350254-00
10.....	2		5/8"	DRAW PIN / SPRING PIN	357035-00

ROADMASTER, INC.



BASEPLATE KIT INSTALLATION INSTRUCTIONS

KIT# 822-3

8/23/04

ROADMASTER, Inc. 6110 NE 127th Ave. Vancouver, WA 98682 360-896-0407 fax 360-735-9300 www.roadmasterinc.com

Item	Qty.	Part #	Description
1	1	C-001040	MAIN RECEIVER BRACE WELDMENT
2	1	C-001043	DRIVER SIDE ARM TUBE
3	1	C-001044	PASSENGER SIDE ARM TUBE
4	2	C-001045	THREADED BACKING PLATE WITH WELD NUTS
5	1	C-001048	DRIVER SIDE SIDE BRACE
6	1	C-001049	PASSENGER SIDE SIDE BRACE
7	1	C-001050	DRIVER SIDE REAR BRACE
8	1	C-001051	PASSENGER SIDE REAR BRACE
9	1	C-001052	DRIVER SIDE BACK PLATE
10	1	A-001708	3/16" x 2" x 3 7/8" PLATE

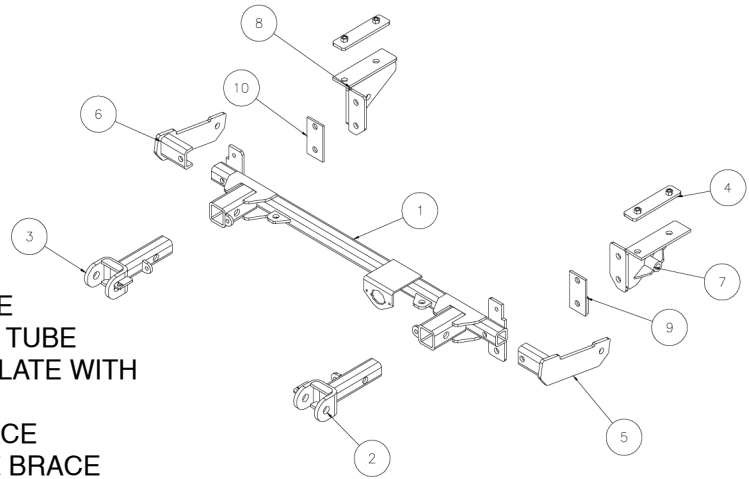

IMPORTANT: All baseplates **must** be assembled with all the bolts left loose for final adjustment and positioning (before tightening) unless otherwise instructed. All bolts **must** be torqued for proper strength. If more than one bolt is used per fastening point, the diagram may only show one. Use flat washers over all slotted holes and lock washers on all fasteners.

WARNING

Failure to heed these warnings or follow the installation instructions may result in a voided warranty, loss of towed vehicle, personal injury or death.

- Do not weld or modify this baseplate or its components. Welding or modification will void the warranty.
- Do not use this document as a basis to design/fabricate a baseplate, as it may not show all parts or structural components.
- We strongly recommend professional installation.
- If the towed vehicle has been in an accident, it must be properly repaired before attaching the baseplate. Do not install the baseplate if any structural frame damage is found.
- The installer must use all bolts and parts supplied. If running changes were made by the vehicle manufacturer after this kit was designed, some bolts or other fasteners may no longer be the correct size. It is the installer's responsibility to verify this kit is securely fastened to the vehicle.
- Use Loctite® Red on all bolts used to secure this baseplate. Torque all bolts to the specifications found at the end of these instructions. Do not over-torque the bolts or failure may occur.
- The installer must inspect the baseplate to ensure adequate clearance, particularly around hoses, air conditioner lines, radiators, etc. or non-warranty failure may result.
- Roadmaster manufactures many styles of baseplates. If your baseplate has removable arms, they must be removed before driving the vehicle, unless the arms can be pinned or padlocked in place. If not secured, the arms could vibrate out.
- Some motorhome chassis have such a tight turning radius that you can damage your motorhome, towed vehicle, tow bar or baseplate while turning sharply. Before getting on the road, test your turning radius in an empty parking lot. Turning too sharply could result in non-warranty damage to your towing system, motorhome and/or towed vehicle.
- Do not back up with the towed vehicle attached or non-warranty damage will occur to your towing system or vehicles.
- The safety cables must connect the towing vehicle to the towed vehicle frame to frame, with the cables crossed, with enough slack for sharp turns. See cable instructions for proper routing. Failure to do so will result in non-warranty damage and/or the loss of the towed vehicle.
- This kit is designed for use with ROADMASTER tow bars and ROADMASTER adapters only. Using this kit with other brands, without an approved ROADMASTER adapter, may result in non-warranty damage or injury.
- Receiver extensions and out-of-level towing situations of 3 inches or more. This can cause the system to swing much higher and lower, causing excessive strain on the tow bar, baseplate and frame. That can cause the towing system to fail, causing property damage, personal injury or even death. If you must use a receiver extension or drop hitch to tow, it will reduce your receiver's weight capacity by 1/3 to avoid damaging your system. Never use more than one extension and/or drop hitch, as this will void your warranty.
- Every 3,000 miles, the owner must inspect all mounting points for cracks or fatigue, and check the fasteners for proper torque, according to the bolt torque requirements chart on the last page of these instructions.
- The owner must follow the vehicle manufacturer's instructions to prepare the vehicle for towing. Failure to do so may cause severe damage to the vehicle.
- This baseplate is only warranted for the original installation. Installing a used baseplate on another vehicle is not recommended and will void the warranty.



BASEPLATE KIT INSTALLATION INSTRUCTIONS

KIT# 822-3

8/23/04

ROADMASTER, Inc. 6110 NE 127th Ave. Vancouver, WA 98682 360-896-0407 fax 360-735-9300 www.roadmasterinc.com

This bracket kit is one of our MX series (Fig.A). The kit consists of the main receiver brace, two front arm braces, two side braces, two rear braces and a hardware pack.

Start by laying the kit out according to the illustration. This will give you a visual idea of how the kit installs and also confirm that all the components are present and accounted for.



1. **Important:** please use all supplied bolts and parts and read all instructions carefully before beginning this installation. The majority of questions you may have can be answered within the text, and proper installation will ensure safe and secure travel. Now, begin the installation. Start by removing the 8 plastic fasteners on the top of the fascia between the headlights, then remove the grill inserts by pulling them forward (Fig.B,C).

2. Remove two 10mm head bolts located under the grille inserts, one on each side (Fig.D).

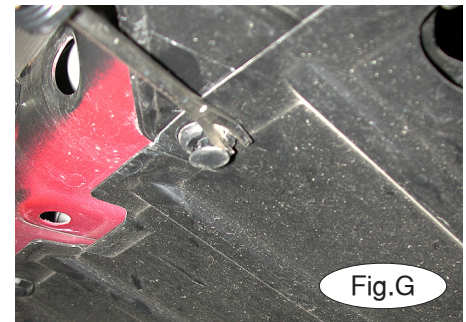
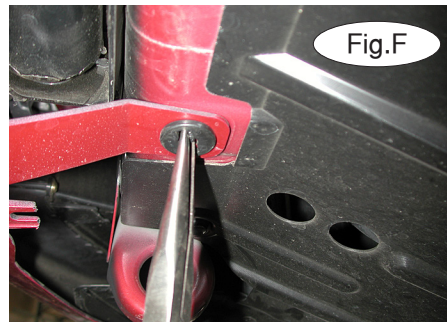

3. From each fender well remove one 10mm head screw and two plastic fasteners (Fig.E).

4. Using needle nose pliers, remove the two plastic fasteners from the bottom of the fascia which connects fascia to the core support (Fig.F).

5. Now remove the two splash panels by using a screwdriver to pry the 13 plastic fasteners out (Fig.G).

6. Remove the fascia by pulling down and then forward at each side. Note: If fog lights are present be sure while pulling the fascia to unplug the fog lights (Fig.H,I).

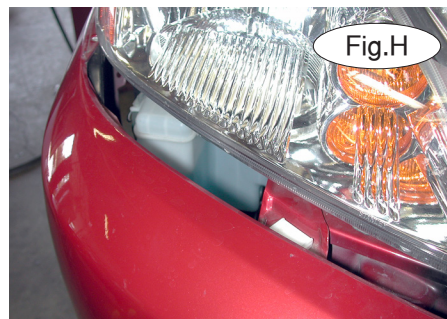



BASEPLATE KIT INSTALLATION INSTRUCTIONS

KIT# 822-3

8/23/04

ROADMASTER, Inc. 6110 NE 127th Ave. Vancouver, WA 98682 360-896-0407 fax 360-735-9300 www.roadmasterinc.com

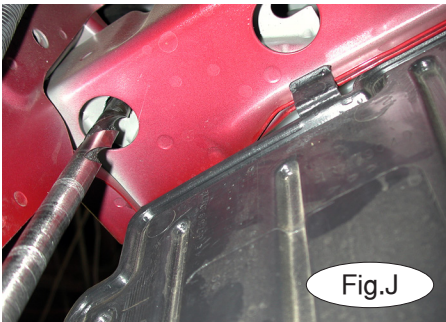

Fig.J

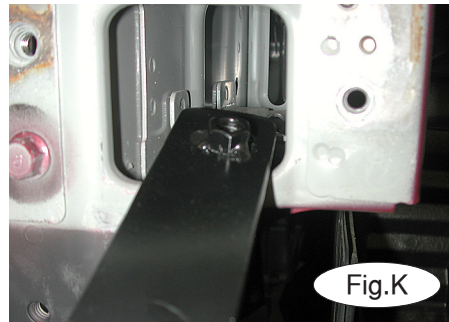

Fig.K



Fig.L

7. Remove two 12mm head bolts at each end of the bumper and remove the bumper core.
8. Locate the two factory holes on each side of the frame rail, enlarge the front hole to 1/2" diameter (Fig.J).
9. Insert the 1/4" X 1 1/2" X 6" nutted backing plate into the frame rail with the narrow side towards the outside of the car (Fig.K). Now bolt the rear brace to the backing plate using a 3/8" X 2" bolts, flat washers and lock washers and bolting up through the frame rail and into the backing plate (Fig.L). Repeat this for the other side.

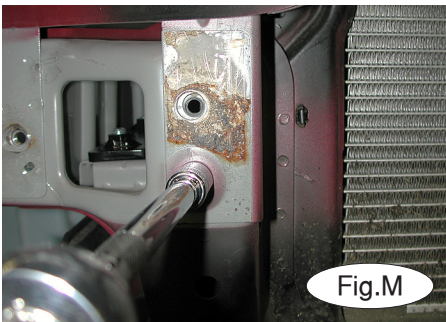

Fig.M

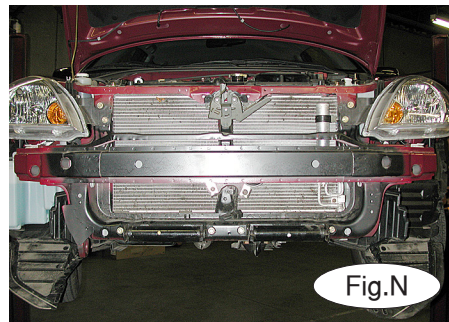

Fig.N

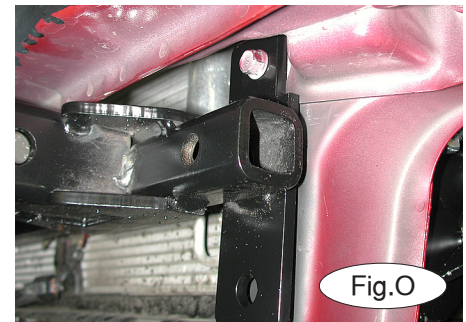

Fig.O

10. Remove two existing 12mm head bolts from the front of the radiator support, one on each side.(Fig.M)
11. Then replace the bumper core using the original bolts and securely tighten into place (Fig.N).
12. Using the two 12mm head bolts that were removed in step #10, bolt the main brace to the front of the radiator as shown in Figure O.

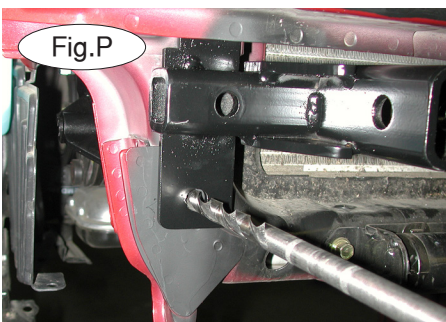

Fig.P

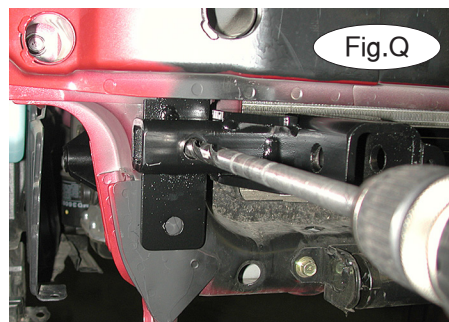

Fig.Q

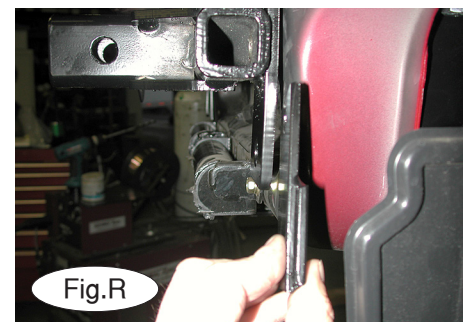

Fig.R

13. Using the remaining mounting holes in the main brace as a template drill through the radiator support with a 17/32" drill bit on both sides (Fig.P,Q). Now insert the flat backing plate between the main brace and the radiator support on the passenger side of the car and insert the raised backing between the main brace and the radiator support on the driver side of the car (Fig.R).



BASEPLATE KIT INSTALLATION INSTRUCTIONS

KIT# 822-3

8/23/04

ROADMASTER, Inc. 6110 NE 127th Ave. Vancouver, WA 98682 360-896-0407 fax 360-735-9300 www.roadmasterinc.com

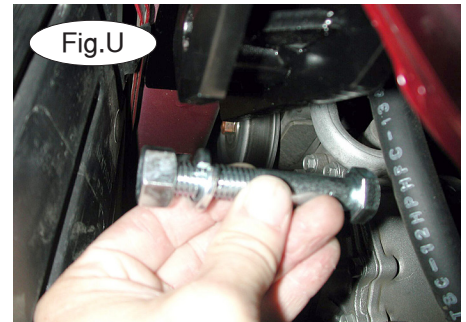
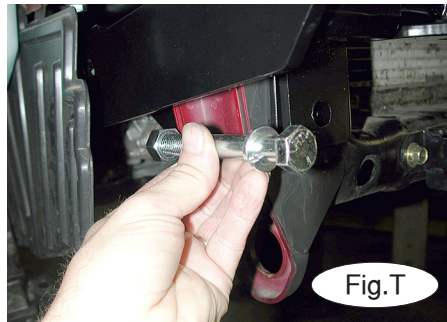
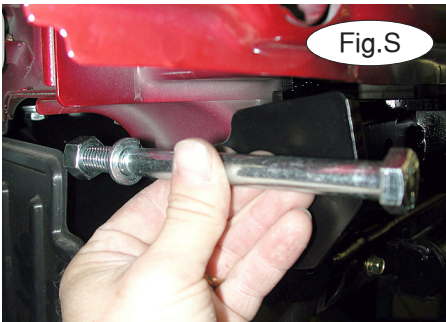

14. To mount the side braces start with the top hole on the main brace and bolt through with a 1/2" x 6" bolt and lock washer through the main bracket, radiator support, rear brace and nut on both sides. In the lower hole insert a 1/2" x 4" bolt, lock washer through the main bracket, radiator support and rear brace on both sides (Fig.S,T).
15. Bolt side brace to rear brace using a 1/2" x 3" bolt, lock washer and nut on each side (Fig.U).
16. Trim the lower grill insert as shown in Figure V.
17. Replace fascia by reversing steps 1 through 6.
18. Insert the front braces into receiver tubes and pin in place with a 5/8" draw pin and spring pin on each side.
19. Install the tow bar according to the manufacturer's instructions and torque all mounting bolts to the specifications below. Attach the safety cables to the main receiver brace.

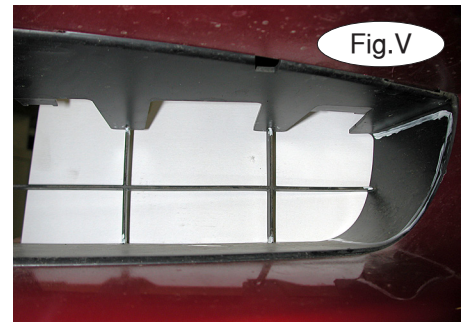

BOLT TORQUE REQUIREMENTS

Note: The torque values represented below are intended as general guidelines. Torque requirements for specific applications may vary. Roadmaster does not warrant this information to be accurate for all applications and disclaims all liability for any claims or damages which may result from its use.

STANDARD BOLTS

Thread Size	Grade	Torque
5/16.....	5.....	13 ft./lb.
3/8.....	5.....	23 ft./lb.
7/16.....	5.....	37 ft./lb.
1/2.....	5.....	56 ft./lb.
5/8.....	5.....	150 ft./lb.

METRIC BOLTS

Thread Size	Grade	Plated / Unplated
8mm-1.0	8.8	20 ft./lb. 18 ft./lb.
8mm-1.25	8.8	19 ft./lb. 18 ft./lb.
10mm-1.25	8.8	38 ft./lb. 36 ft./lb.
10mm-1.5	8.8	37 ft./lb. 35 ft./lb.

METRIC BOLTS

Thread Size	Grade	Plated / Unplated
12mm-1.25	8.8	70 ft./lb. 65 ft./lb.
12mm-1.5	8.8	66 ft./lb. 61 ft./lb.
12mm-1.75	8.8	65 ft./lb. 60 ft./lb.
14mm-2.0	8.8	104 ft./lb. 97 ft./lb.