



BASEPLATE KIT INSTALLATION INSTRUCTIONS

KIT# 919-1

04/1/19
KS

ROADMASTER, Inc. 6110 NE 127th Ave. Vancouver, WA 98682 360-896-0407 fax 360-735-9300 www.roadmasterinc.com

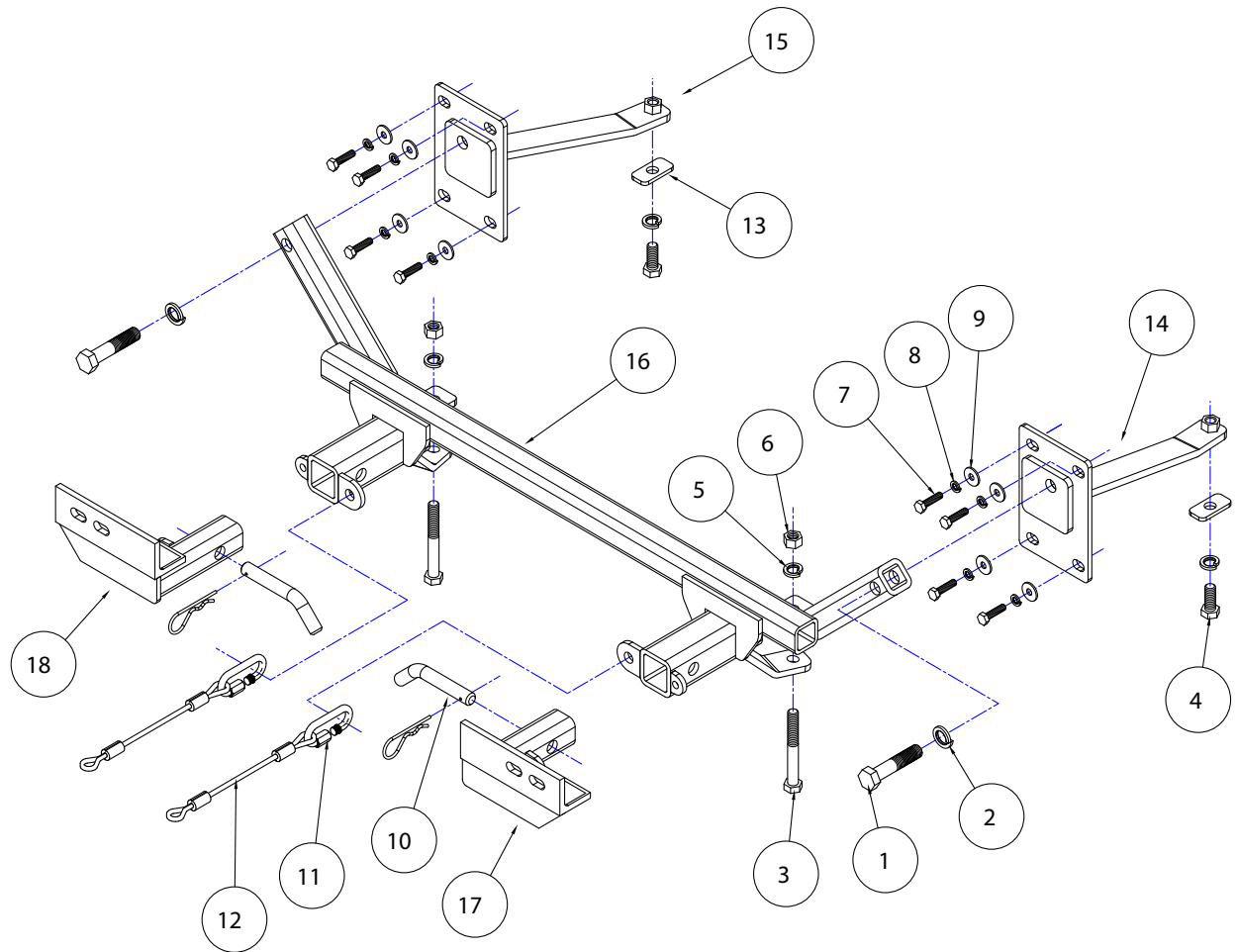

ITEM	QTY	NAME	MATERIAL
1.....	2.....	5/8" x 3" BOLT.....	350154-00
2.....	2.....	5/8" LOCK WASHER.....	350313-00
3.....	2.....	1/2" x 4" BOLTS.....	350105-00
4.....	2.....	1/2" x 1 1/2" BOLT.....	350095-00
5.....	4.....	1/2" LOCK WASHER.....	350309-00
6.....	2.....	1/2" HEX NUT.....	350258-00
7.....	8.....	M8 x 1.25 x 30 mm BOLT.....	356001-00
8.....	8.....	M8 LOCK WASHER.....	355705-00
9.....	8.....	M8 FENDER WASHER.....	355702-00
10.....	2.....	5/8" DRAW PIN W/ CLIP.....	357035-00
11.....	2.....	QUICK LINK.....	200008-00
12.....	2.....	8" SAFETY CABLE.....	650646-08
13.....	2.....	3/16" x 1" x 2" BACKING PLATE.....	A-000842
14.....	1.....	DRIVER SIDE BRACE.....	C-001602
15.....	1.....	PASSENGER SIDE BRACE.....	C-001603
16.....	1.....	MAIN RECEIVER.....	C-001599
17.....	1.....	DRIVER SIDE ARM.....	C-001600
18.....	1.....	PASSENGER SIDE ARM.....	C-001601



BASEPLATE KIT INSTALLATION INSTRUCTIONS

KIT# 919-1

04/1/19
KS

ROADMASTER, Inc. 6110 NE 127th Ave. Vancouver, WA 98682 360-896-0407 fax 360-735-9300 www.roadmasterinc.com

This bracket kit is one of our XL series, which allows the visible front portion of the brackets to be easily removed (Fig.A and Fig.B). The kit consists of the main receiver brace, two rear braces, removable front braces and a hardware pack.

The main receiver brace mounts to the frame rails and bumper core mounts on each side. The removable front braces insert into the receivers on each side and are secured with draw pins.

Before starting the installation, lay out the kit components in order, as they will be used. This will give you a visual idea of how the components work, and will also confirm that everything is present and accounted for.



IMPORTANT: All baseplates **must** be assembled with all the bolts left loose for final adjustment and positioning (before tightening) unless otherwise instructed. All bolts **must** be torqued for proper strength. If more than one bolt is used per fastening point, the diagram may only show one. Use flat washers over all slotted holes and lock washers on all fasteners.

WARNING

Failure to heed these warnings or follow the installation instructions may result in a voided warranty, loss of towed vehicle, personal injury or death.

- Do not weld or modify this baseplate or its components. Welding or modification will void the warranty.
- Do not use this document as a basis to design/fabricate a baseplate, as it may not show all parts or structural components.
- We strongly recommend professional installation.
- If the towed vehicle has been in an accident, it must be properly repaired before attaching the baseplate. Do not install the baseplate if any structural frame damage is found.
- The installer must use all bolts and parts supplied. If running changes were made by the vehicle manufacturer after this kit was designed, some bolts or other fasteners may no longer be the correct size. It is the installer's responsibility to verify this kit is securely fastened to the vehicle.
- Use Loctite® Red on all bolts used to secure this baseplate. Torque all bolts to the specifications found at the end of these instructions. Do not over-torque the bolts or failure may occur.
- The installer must inspect the baseplate to ensure adequate clearance, particularly around hoses, air conditioner lines, radiators, etc. or non-warranty failure may result.
- Roadmaster manufactures many styles of baseplates. If your baseplate has removable arms, they must be removed before driving the vehicle, unless the arms can be pinned or padlocked in place. If not secured, the arms could vibrate out.
- Some motorhome chassis have such a tight turning radius that you can damage your motorhome, towed vehicle, tow bar or baseplate while turning sharply. Before getting on the road, test your turning radius in an empty parking lot. Turning too sharply could result in non-warranty damage to your towing system, motorhome and/or towed vehicle.
- Do not back up with the towed vehicle attached or non-warranty damage will occur to your towing system or vehicles.
- The safety cables must connect the towing vehicle to the towed vehicle frame to frame, with the cables crossed, with enough slack for sharp turns. See cable instructions for proper routing. Failure to do so will result in non-warranty damage and/or the loss of the towed vehicle.
- This kit is designed for use with ROADMASTER tow bars and ROADMASTER adapters only. Using this kit with other brands, without an approved ROADMASTER adapter, may result in non-warranty damage or injury.
- Receiver extensions and out-of-level towing situations of 3 inches or more. This can cause the system to swing much higher and lower, causing excessive strain on the tow bar, baseplate and frame. That can cause the towing system to fail, causing property damage, personal injury or even death. If you must use a receiver extension or drop hitch to tow, it will reduce your receiver's weight capacity by 1/3 to avoid damaging your system. Never use more than one extension and/or drop hitch, as this will void your warranty.
- Every 3,000 miles, the owner must inspect all mounting points for cracks or fatigue, and check the fasteners for proper torque, according to the bolt torque requirements chart on the last page of these instructions.
- The owner must follow the vehicle manufacturer's instructions to prepare the vehicle for towing. Failure to do so may cause severe damage to the vehicle.
- This baseplate is only warranted for the original installation. Installing a used baseplate on another vehicle is not recommended and will void the warranty.



BASEPLATE KIT INSTALLATION INSTRUCTIONS

KIT# 919-1

04/1/19
KS

ROADMASTER, Inc. 6110 NE 127th Ave. Vancouver, WA 98682 360-896-0407 fax 360-735-9300 www.roadmasterinc.com

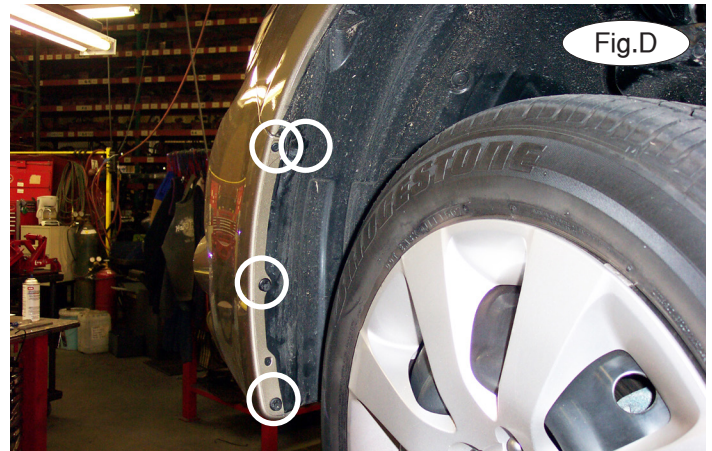

1. **Important:** please use all supplied bolts and parts and read all instructions carefully before beginning this installation. The majority of questions you may have can be answered within the text, and proper installation will ensure safe and secure travel. Now, begin the installation by removing four plastic fasteners attaching the top of the fascia to the radiator core (Fig.C).

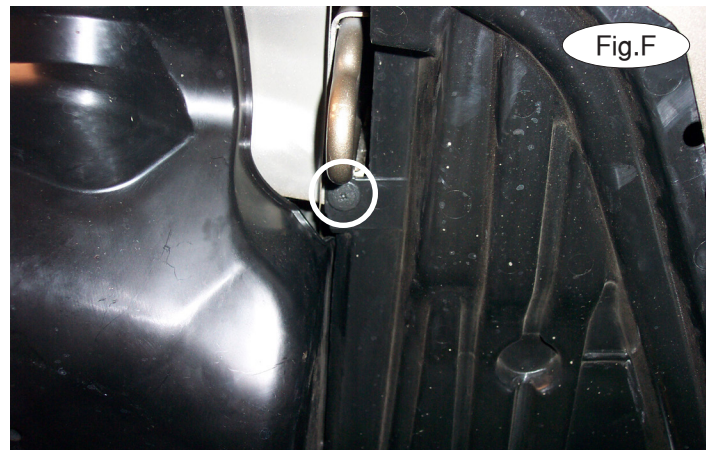

2. On each side, remove four plastic fasteners attaching the edge of the fascia to the fender liner (Fig.D).
3. Remove six plastic fasteners attaching the splash shield to the lower edge of the fascia (Fig.E).
4. On each side, remove one plastic fastener attaching the splash shield to the core support. *Note:* the fastener is located directly behind the tie down hooks (Fig.F).
5. On each side, remove one 12mm (head) bolt attaching the splash shield to the radiator support (Fig.G).

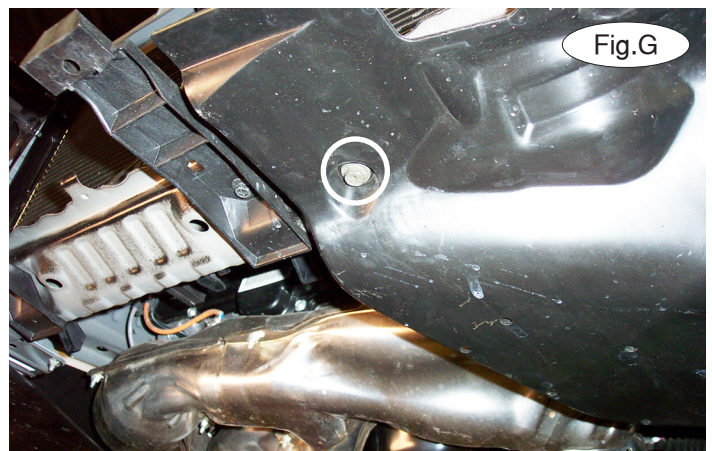



BASEPLATE KIT INSTALLATION INSTRUCTIONS

KIT# 919-1

04/1/19
KS

ROADMASTER, Inc. 6110 NE 127th Ave. Vancouver, WA 98682 360-896-0407 fax 360-735-9300 www.roadmasterinc.com

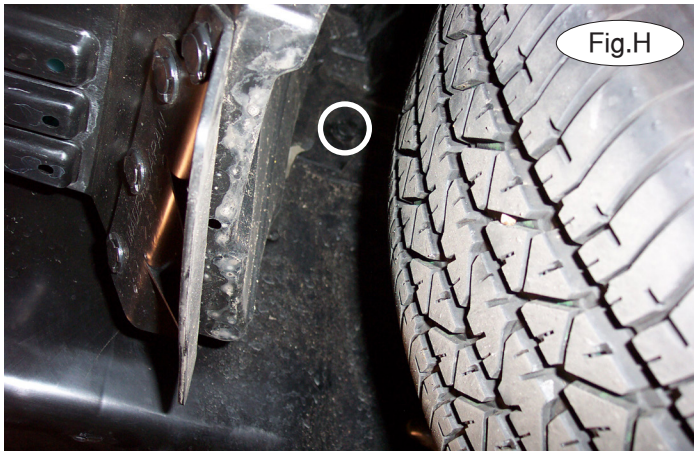

6. On each side, remove one plastic fastener attaching the splash shield to the frame rail (Fig.H).

7. Pull back the fender liner and remove two 8mm screws attaching the fascia to the fender. Their approximate location is noted in Figure I.

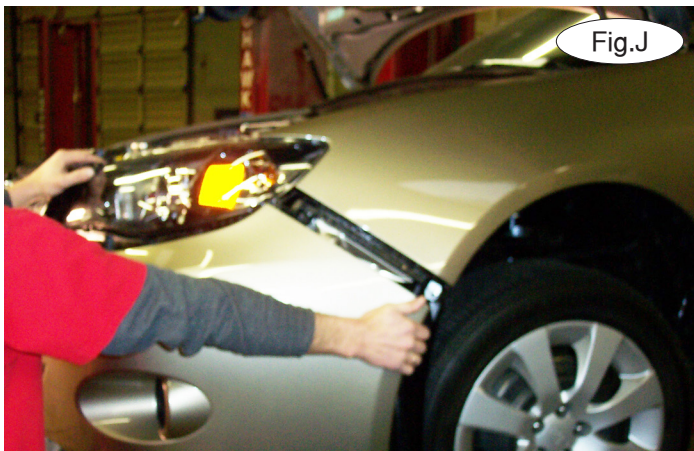

8. Disconnect the fog lights, if the vehicle is so equipped.

9. Pull out and forward on the corners of the fascia to remove it (Fig.J).

10. On each side, remove four 12mm (head) bolts attaching the bumper core to the frame rail. The bumper core will not be replaced. *Note:* retain the bumper core and attachment hardware so that it can be replaced if the bracket is ever removed.

11. On each side, insert the rear brace into the end of the frame rail (Fig.L). Bolt the brace into place using the four supplied 8mm x 1.25 x 30mm bolts and 8mm fender washers and lock washers. *Note:* use Loctite® Red on all bolts used for mounting this bracket.

12. On each side, position the main receiver brace over the core support and bolt it to the rear brace using the supplied 5/8" x 3" bolt and 5/8" lock washer.

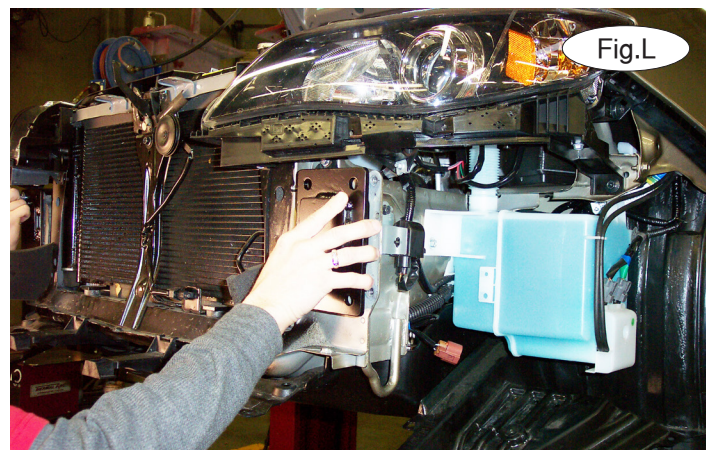



BASEPLATE KIT INSTALLATION INSTRUCTIONS

KIT# 919-1

04/1/19
KS

ROADMASTER, Inc. 6110 NE 127th Ave. Vancouver, WA 98682 360-896-0407 fax 360-735-9300 www.roadmasterinc.com

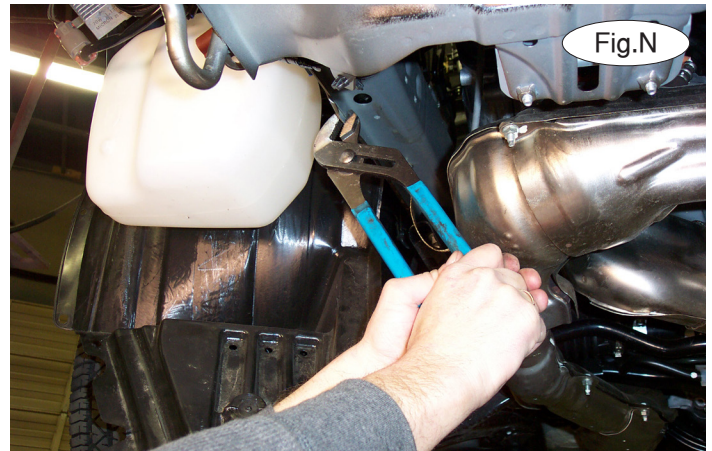
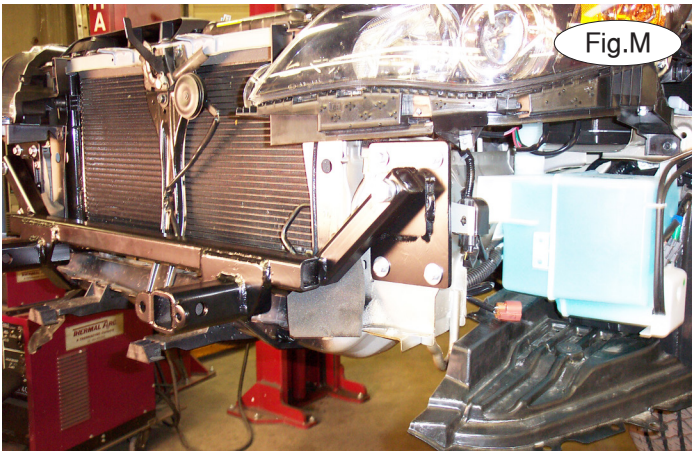

13. On each side, tighten the four 8mm (head) bolts you installed in step 11 (Fig.M) to the bolt torque requirements found at the end of these instructions.

14. Tighten the two 5/8" bolts you installed in step 12 to the bolt torque requirements found at the end of these instructions.

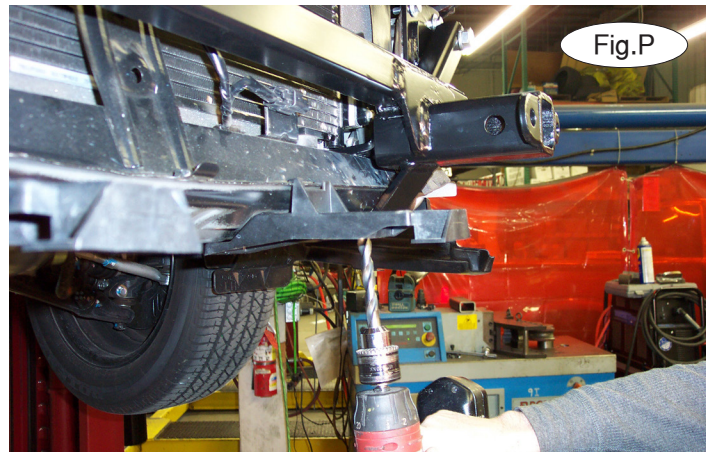

15. On each side, use a pair of pliers to bend the lip of the frame rail out slightly next to the pre-existing hole in the bottom of the frame (Fig.N). This will allow clearance for the head of an attachment bolt. *Note:* due to manufacturing variances, the hole may need to be slightly enlarged with a die grinder.

On each side, place one of the supplied 1/2" lock washers over a 1/2" x 1 1/2" bolt. Place the bolt over a 3/16" x 1" x 2" backing plate and bolt through the pre-existing hole in the frame and into the weld nut in the rear support brace (Fig.O).

16. On each side, using the lower outside mounting point as a template, drill a 1/2" hole through the bottom and top layers of the radiator support. *Note:* use a piece of metal as a buffer to protect the engine components (Fig.P).

Using one of the supplied 1/2" x 4 1/2" bolts and 1/2" lock washer and nut, bolt through the bottom of the lower support brace, the radiator support and the top of the lower support brace (Fig.Q).

17. Tighten all remaining bolts to the bolt torque requirements found at the end of these instructions.

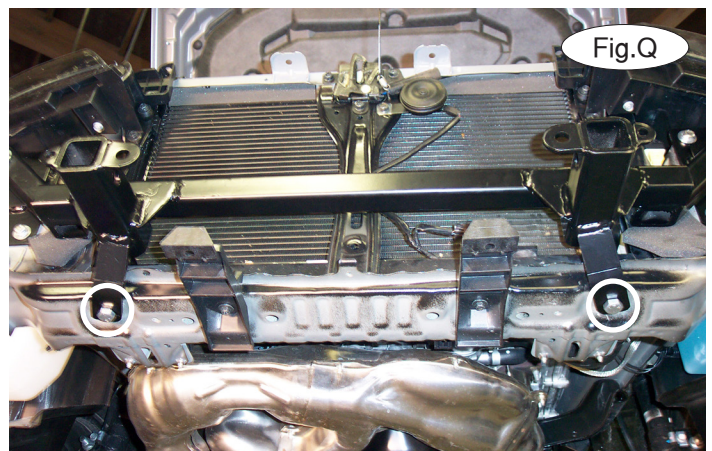



BASEPLATE KIT INSTALLATION INSTRUCTIONS

KIT# 919-1

04/1/19
KS

ROADMASTER, Inc. 6110 NE 127th Ave. Vancouver, WA 98682 360-896-0407 fax 360-735-9300 www.roadmasterinc.com

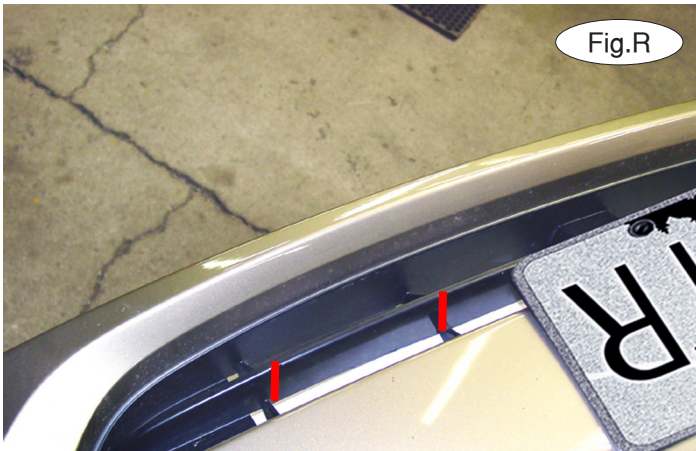

18. On each side, trim the outside horizontal center ribs of the fascia to allow clearance for the main receiver brace. Use the red lines in Figure R as a guide for trimming.
19. Reassemble the fascia, reversing steps 1 through 9. The red lines in Figure S denote the areas you trimmed in step 18.
20. Insert the removable front bracket arms into the front receiver braces, and secure them in place with the supplied 5/8" draw pins and spring pins.
21. Attach the 8" safety cables with the cable connectors (Q-Links) to the front of the receiver braces (Fig.T).
22. Attach the ends of the safety cables to the tow vehicle's safety cables and tow bar.
23. Install the tow bar to the mounting bracket according to the manufacturer's instructions.



BOLT TORQUE REQUIREMENTS

Note: The torque values represented below are intended as general guidelines. Torque requirements for specific applications may vary. Roadmaster does not warrant this information to be accurate for all applications and disclaims all liability for any claims or damages which may result from its use.

STANDARD BOLTS

Thread Size	Grade	Torque
5/16.....	5.....	13 ft./lb.
3/8.....	5.....	23 ft./lb.
7/16.....	5.....	37 ft./lb.
1/2.....	5.....	56 ft./lb.
5/8.....	5.....	150 ft./lb.

METRIC BOLTS

Thread Size	Grade	Plated / Unplated
8mm-1.0.....	8.8.....	20 ft./lb. 18 ft./lb.
8mm-1.25.....	8.8.....	19 ft./lb. 18 ft./lb.
10mm-1.25.....	8.8.....	38 ft./lb. 36 ft./lb.
10mm-1.5.....	8.8.....	37 ft./lb. 35 ft./lb.

METRIC BOLTS

Thread Size	Grade	Plated / Unplated
12mm-1.25.....	8.8.....	70 ft./lb. 65 ft./lb.
12mm-1.5.....	8.8.....	66 ft./lb. 61 ft./lb.
12mm-1.75.....	8.8.....	65 ft./lb. 60 ft./lb.
14mm-2.0.....	8.8.....	104 ft./lb. 97 ft./lb.

All illustrations and specifications contained herein are based on the latest information available at the time of publication approval. ROADMASTER, INC. reserves the right to make changes at any time without notice in material, specification and models or to discontinue models.