



STEERING STABILIZER INSTALLATION INSTRUCTIONS

KIT# RBK18

85-4245-08
01-24

ROADMASTER, Inc. 6110 NE 127th Ave. Vancouver, WA 98682 360-896-0407 fax 360-735-9300 www.roadmasterinc.com

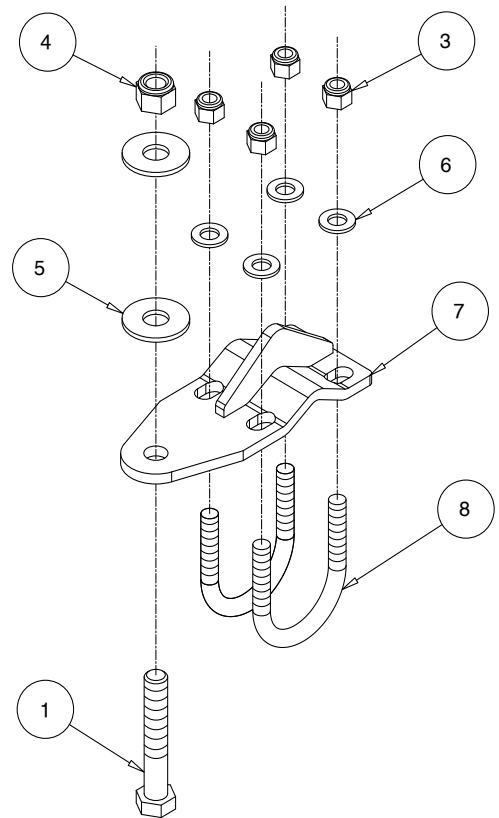
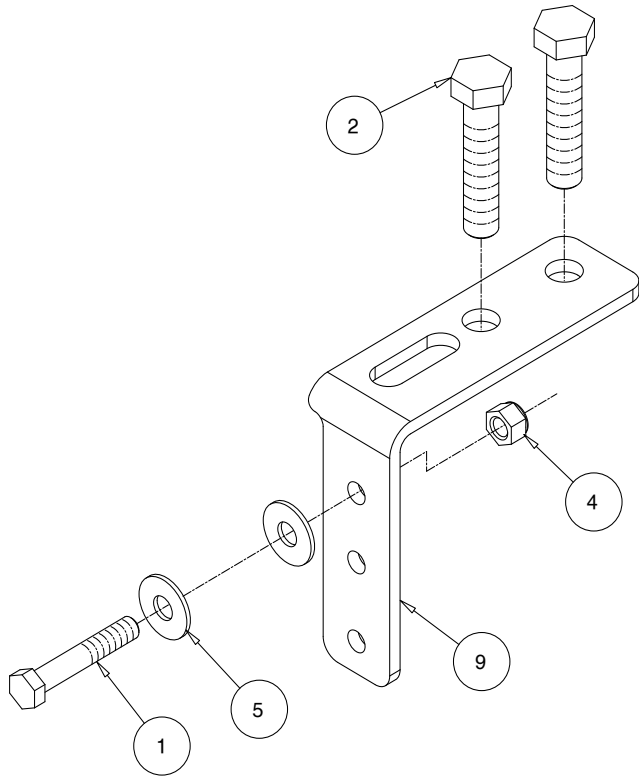

| ITEM | QTY | MATERIAL | NAME |
|------|-----|----------------------------|-----------|
| 1 | 2 | 1/2" x 3" BOLT | 350101-50 |
| 2 | 2 | 3/4" x 3 1/2" BOLT | 350182-10 |
| 3 | 4 | 3/8" NYLON INSERT LOCK NUT | 350255-00 |
| 4 | 2 | 1/2" NYLON INSERT LOCK NUT | 350259-01 |
| 5 | 4 | 1/2" FLAT WASHER | 350308-00 |
| 6 | 4 | M10 FLAT WASHER | 355710-00 |
| 7 | 1 | TIE ROD BRACKET | B802 |
| 8 | 3 | U-BOLT | LRG38 |
| 9 | 1 | AXLE BRACKET | B1023 |
| 10 | 1 | LOCTITE | 200544-00 |



STEERING STABILIZER INSTALLATION INSTRUCTIONS

KIT# RBK18

85-4245-08
01-24

ROADMASTER, Inc. 6110 NE 127th Ave. Vancouver, WA 98682 360-896-0407 fax 360-735-9300 www.roadmasterinc.com

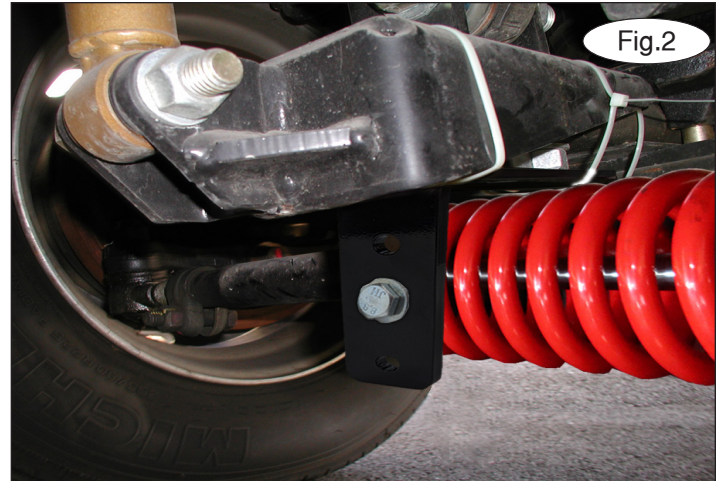

Note: Roadmaster makes multiple steering stabilizers. The unit depicted in these instructions may vary from your unit but all stabilizers will follow these instructions. If installing a Reflex, ensure that the spring is fully-seated in its track on the collar of the unit. If it is installed without the spring fully-seated in its track, the unit could malfunction or otherwise fail to operate properly (Fig.1).

1. **Note: The coach must be at normal ride height for proper installation. Center the steering wheel and lock it into place.**

2. Locate the shock mount bar from the front axle toward the rear on the driver's side. Remove the nuts from the bottom side of this bracket. They will be used later in the installation. Remove and discard the bolts. Replace them with the supplied $\frac{3}{4}$ " x $3\frac{1}{2}$ " bolts. Install the B1023 axle bracket on these bolts (Fig.2).

3. Install the B802 tie rod bracket by placing the indentation on the top of the tie rod with the $\frac{9}{16}$ " mounting hole facing the rear of the motorhome. The bracket will be parallel to the ground. Using the two supplied $\frac{3}{8}$ " U-bolts, washers, and lock nuts, loosely clamp the tie rod bracket to the tie rod (Fig.3). Torque the hardware to approximately 30 ft./lbs.

4. Install the Reflex stabilizer to the brackets. Place one mounting bolt through the chassis bracket with the threads of the bolt facing the ground. Choose the mounting hole that allows for optimal clearance. **Note: On units with 150-gallon fuel tanks, the hole closest to the axle will be necessary for clearance.** Then, place one $\frac{1}{2}$ " washer on both sides of the stabilizer mounting loop nearest to the aluminum casting, and place it on a mounting bolt. Secure the end with a lock nut. Finger-tighten only at this time.



continued on the next page



STEERING STABILIZER INSTALLATION INSTRUCTIONS

KIT# RBK18

85-4245-08
01-24

ROADMASTER, Inc. 6110 NE 127th Ave. Vancouver, WA 98682 360-896-0407 fax 360-735-9300 www.roadmasterinc.com

5. Adjust the tie rod bracket so that the Reflex stabilizer unit is in a level position and then tighten the U-bolt lock nuts. Then, tighten both of the stabilizer mounting lock nuts (Fig.4).

Note: When you unload the air in the system, ensure that it doesn't interfere with the suspension or the fuel tank.

7. Test drive the vehicle to make certain that the Reflex stabilizer is adjusted properly. If the steering pulls to either side, center it by loosening the bracket U-bolts at the tie rod, and then reposition it. Tighten the bolts and test drive it once again, repeating the process until the proper adjustment is achieved. **This concludes the installation of the Reflex.**



BOLT TORQUE REQUIREMENTS

| STANDARD BOLTS | | | U-BOLTS | |
|----------------|-------|--------------|---------|--------------|
| Thread | Grade | Torque | Thread | Torque |
| 3/8 | 5 | 30 ft./lbs. | 3/8-24 | 35 ft./lbs. |
| 7/16 | 5 | 50 ft./lbs. | 1/2-20 | 70 ft./lbs. |
| 1/2 | 5 | 75 ft./lbs. | 5/8-18 | 140 ft./lbs. |
| 5/8 | 5 | 140 ft./lbs. | 3/4-16 | 250 ft./lbs. |
| | | | 7/8-14 | 400 ft./lbs. |

Note: Endlink bolts use grommets and should NOT be torqued. Tighten these bolts by hand until the grommet starts to deform. Also, these torque values are intended as general guidelines. Roadmaster does not warrant his information to be accurate for all applications and disclaims all liability for any claims or damages which may result from its use.

WARNING

Failure to follow these instructions can result in property damage, personal injury or even death.

- The installer must read the instructions and use all bolts and parts supplied. Failure to securely fasten the stabilizer could result in loss of the stabilizer, damage to the vehicle, personal injury or even death.
- There must be adequate clearance between the Steering Stabilizer and all chassis and steering parts, and any other components, or non-warranty damage to the vehicle will result. After final installation, the installer must inspect the stabilizer to ensure adequate clearance. Some minor adjustments may be needed to achieve this; always verify that the steering wheel remains centered before and after these adjustments.
- Always test drive the vehicle to confirm the steering wheel settings. If the vehicle pulls to either side, the center positioning must be adjusted. If the steering wheel does not return to the center position, the tie rod bracket may require minor adjustments. Failure to adjust the center positioning may result in a loss of vehicular control.
- After installing this Steering Stabilizer, any technician who is performing alignment or suspension work on the motorhome must loosen the tie-rod bracket to adjust the toe; the technician must also re-adjust the steering damper. Failure to adjust the center positioning may result in a loss of vehicular control.
- Regardless of year, make and model, a wide range of options for specific applications may or may not interfere with the installation. It is the

installer's responsibility to make certain that equipment is not damaged once the suspension solution travels through the full range of motion. Failure to ensure adequate clearance could result in non-warranty property damage, personal injury or even death.

- If running changes were made by the vehicle manufacturer after this kit was designed, some bolts or other fasteners in the included hardware pack may no longer be the correct size. It is the installer's responsibility to verify that the stabilizer is securely fastened to the vehicle, and fitted with the correct hardware, to account for these changes. Failure to securely fasten the stabilizer could result in loss of the stabilizer, damage to the vehicle, personal injury or even death.
- Except to adjust for running changes to the vehicle, use only the parts supplied by ROADMASTER to install the stabilizer. Using substandard grade parts or parts of the wrong size may result in loss of the stabilizer, damage to the vehicle, personal injury or even death.
- Once a year, the owner must inspect the fasteners for proper tightness and/or torque, according to the bolt torque requirements chart in these instructions. Failure to securely fasten the stabilizer could result in loss of the stabilizer, damage to the vehicle, personal injury or even death.
- Do not use an air impact wrench when reinstalling bolts, as stripped threads may result.
- This stabilizer is only warranted for the original installation. Installing a used stabilizer on another vehicle is not recommended and will void the warranty.