

Alignment Instructions

All specifications are subject to change without notice.

ROADMASTER, Inc. 6110 NE 127th Ave. Vancouver, WA 98682 800-669-9690 Fax: 360-735-9300 www.roadmasterinc.com

Whenever the axles are changed – from narrow to wide, or from wide to narrow – the dolly must be realigned.

To realign the dolly, follow the two steps below.

Step 1

Square the hubs to the dolly

1. First make certain the steering pin (Figure 1) is in place.
2. With the coupler 18 inches off the ground, jack up the axle just enough to allow you to put blocks under it. Now remove the wheels and fenders.
3. Next you'll need two 24-inch long bars. Each bar may be a level, a square or any straight piece of iron bar. Clamp each of these bars tight to the face of each hub, centering them with the spindle.
4. As illustrated in Figure 2, first measure Line AD. Next measure Line BC. If these dimensions are equal, your hubs are square with the dolly, and you are ready to proceed with the toe-in adjustment (below).
5. If the dimensions are not equal, loosen the lock nuts on the end of Tube A and Tube B (Figure 1). Then, remove the six bolts in the center rod.
6. Rotate Tube A and Tube B as necessary to make Line AD the same length as Line BC. When these measurements are equal, the hubs are square with the dolly.

Step 2

Toe-in adjustment

1. The dolly is designed to operate with 0" - 1/16" toe-in.
2. To adjust the toe-in, turn Tube A and Tube B (Figure 1) **equally** until Line AC (Figure 2) is between 0" and 1/16" less than Line BD (Figure 2).
3. Re-insert the six bolts, washers, nuts, etc. to the center rod.
4. Re-tighten the lock nut at the end of each tie rod.
5. Now re-measure to ensure that the measurements have not changed.
6. Re-assemble the wheels and fenders.
7. Torque all bolts according to the Bolt torque chart (Figure 3). Tighten lug nuts as shown on the Torque pattern for wheel lug nuts chart (Figure 4).

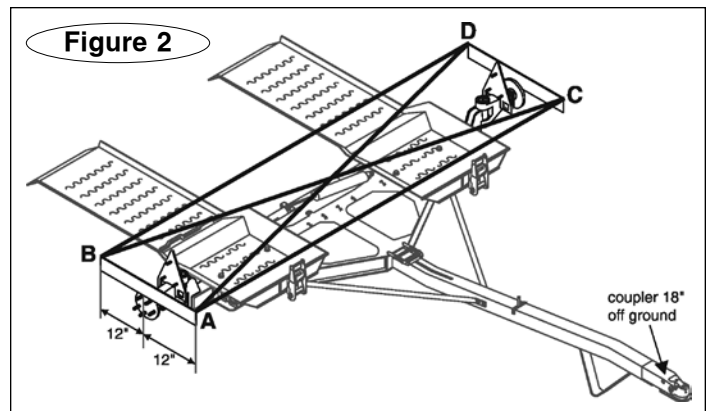
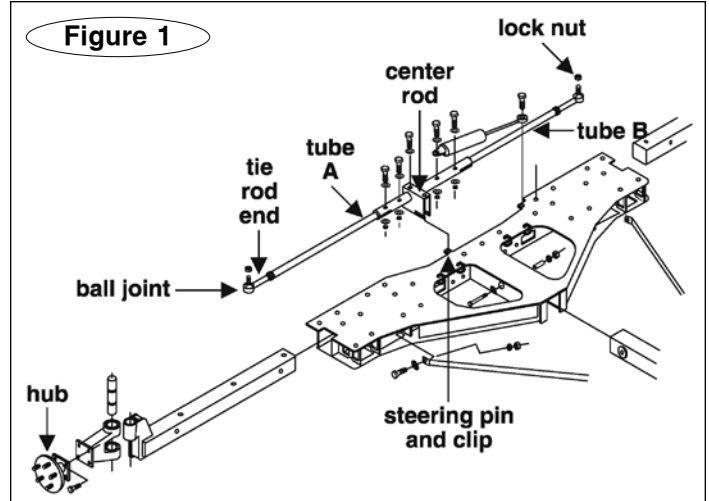

Figure 3

Bolt torque chart

Bolt size	Torque
1/4"	12 ft./lb.
3/8"	38 ft./lb.
1/2"	90 ft./lb.
12mm	63 ft./lb.
Lug nuts	90 ft./lb.

Figure 4

Torque pattern for wheel lug nuts

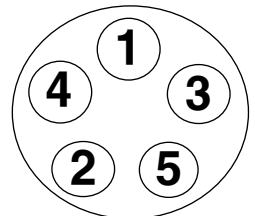

Use this crossing pattern when tightening the lug nuts on the wheels.

