

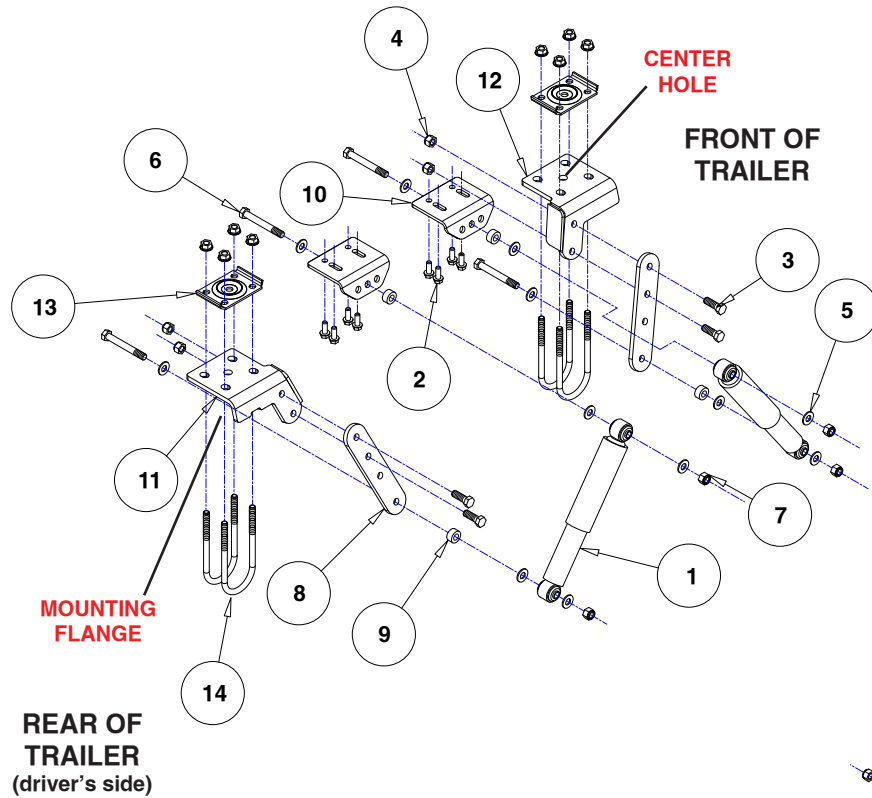

INSTALLATION INSTRUCTIONS

Comfort Ride

Shock absorber system part numbers 24238, 24300 and 24350



ITEM	QTY	DESCRIPTION	PART
1	4	SHOCK ABSORBER	204000-00
2	16	3/8-16 x 1" GRADE 8 SELF TAPPING SCREW - TYPE 23	350054-50
3	8	1/2-13 x 1 1/2" GRADE 8 BOLT - YELLOW	350701-00
4	8	1/2-13 GRADE 8 NYLON INSERT LOCK NUT - YELLOW	350735-00
5	24	M12 FENDER WASHER	355720-10
6	8	M12 x 1.75 x 100mm BOLT - CLASS 8.8	357211-100
7	8	M12 x 1.75 NYLON INSERT LOCK NUT - CLASS 8.8	357212-50
8	4	EXTENSION PLATE	A005494
9	8	1/2" SPACER	A005764
10	4	FRAME BRACKET	B003305
11	2	TIE PLATE FOR 2 3/8" AXLE - 24238	C003264
	2	TIE PLATE FOR 3" AXLE - 24300	C003169
	2	TIE PLATE FOR 3 1/2" AXLE-24350	C003294
12	2	TIE PLATE FOR 2 3/8" AXLE-24238	C003265
	2	TIE PLATE FOR 3" AXLE-24300	C003170
	2	TIE PLATE FOR 3 1/2" AXLE-24350	C003295
13	4	U-BOLT BACKING PLATE FOR 2 3/8" AXLE	B004231
	4	U-BOLT BACKING PLATE FOR 3" AXLE	B004229
	4	U-BOLT BACKING PLATE FOR 3 1/2" AXLE	B004230
14	8	9/16" X 2 3/8" U-BOLT WITH NUTS	357448-00
	8	9/16" X 3" U-BOLT WITH NUTS	357446-00
	8	9/16" X 3 1/2" U-BOLT WITH NUTS	357447-00

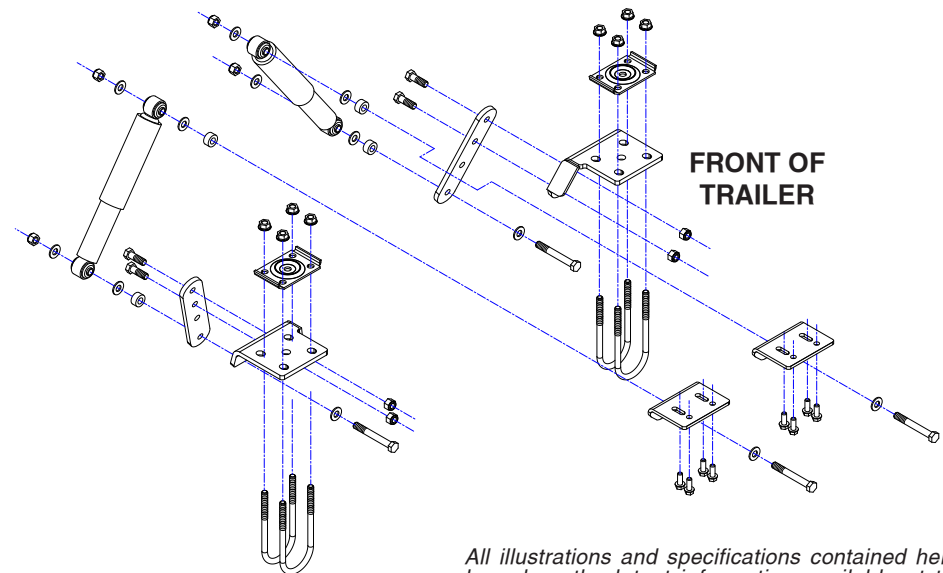

REAR OF TRAILER (passenger side)

All illustrations and specifications contained herein are based on the latest information available at the time of publication approval. ROADMASTER, INC. reserves the right to make changes at any time without notice in material, specification and models or to discontinue models.

Required tools

- General hand tools
- 12" long, 5/16" drill bit
- 9/16", 7/8" socket and wrench
- 3/4" socket and wrench
- Torque wrench
- Blue threadlocker

⚠ WARNING

For ease of installation, the shocks are shipped with restraining bands to hold them at a specific length. Don't remove the restraining bands until instructed to do so. Early removal could result in property damage, serious personal injury or even death.

Safety Definitions

These instructions contain information that is very important to know and understand. This information is provided for **safety** and to **prevent equipment problems**.

To help recognize this information, observe the following symbols:

WARNING

WARNING indicates a potentially hazardous situation which, if not avoided, could result in property damage, serious personal injury or even death.

CAUTION

CAUTION indicates a potentially hazardous situation which, if not avoided, may result in property damage, or minor or moderate personal injury.

ATTENTION

ATTENTION indicates a note of special importance regarding a potential fit issue of which you should be aware.

NOTE

Refers to important information and is placed in italic type. It is recommended that you take special notice of these items.



ROADMASTER, Inc. • 6110 N.E. 127th Ave.
Vancouver, WA 98682

Before you begin the installation...

Refer to the chart below to ensure that you have the correct shock kit for your application.

Shock Kit	Axle Diameter	Axle Circumference
24238	2 3/8"	Approx. 7.5"
24300	3"	Approx. 9.5"
24350	3.5"	Approx. 11"

WARNING

The first shock must be installed with the trailer suspension loaded, i.e., bearing the weight of the trailer. Do this with the trailer on level ground.

If the trailer's axles are above the leaf springs, support the frame with jackstands without taking any weight off the tires. Otherwise, the trailer could drop, which may cause property damage, personal injury or even death.



Figure 1

CAUTION

Don't lift the trailer by the axles. Doing so could adversely affect the alignment of the axles or result in a bent or otherwise damaged axle.

CAUTION

For ease of installation, the shock absorbers are shipped with restraining bands to hold them at a specific length (Figure 1). Don't remove the restraining bands until instructed to do so.

Prepare the Trailer

NOTE

If installing a Comfort Ride slipper leaf spring system with a Comfort Ride shock absorber system, don't follow these instructions. Instead, follow the instructions included with the Comfort Ride slipper leaf spring system.

If you're a professional installer, please give these instructions to the customer once the kit is installed.

- Park the trailer on level ground and chock the tires.
- Make sure that the trailer is at the correct ride height, with both of the equalizer spring shackles pointed in the correct direction (Figure 2).
- Check for any under-vehicle obstructions in and around the trailer's suspension (such as plumbing, wiring or other trailer components) that may prevent the installation of the product.

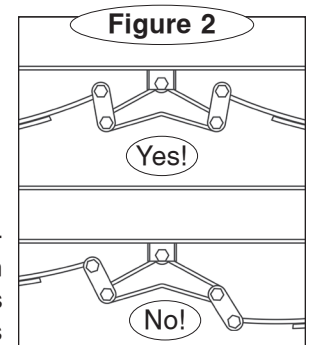

Figure 2

It may be necessary to modify or relocate components in order to install this product.

Install the Tie Plates

ATTENTION

In the following steps, you will be installing a single shock only, beginning on the driver's side rear. The final location of the shock will inform you on the positioning of the other three.

1. On the driver's side rear, remove the U-bolt and its nuts. If necessary, soak the nuts in a quality penetrating oil.

2. Remove the factory tie plate and place the supplied tie plate (#11) in its location on the leaf spring. Position the tie plate so that the alignment pin on the leaf spring engages the center hole in the tie plate (Figures 3 and 4). Ensure the shock mounting flange faces toward the center of the trailer and is positioned between the axles. Refer to the drawing on page 1 to better understand how the parts attach to each other.

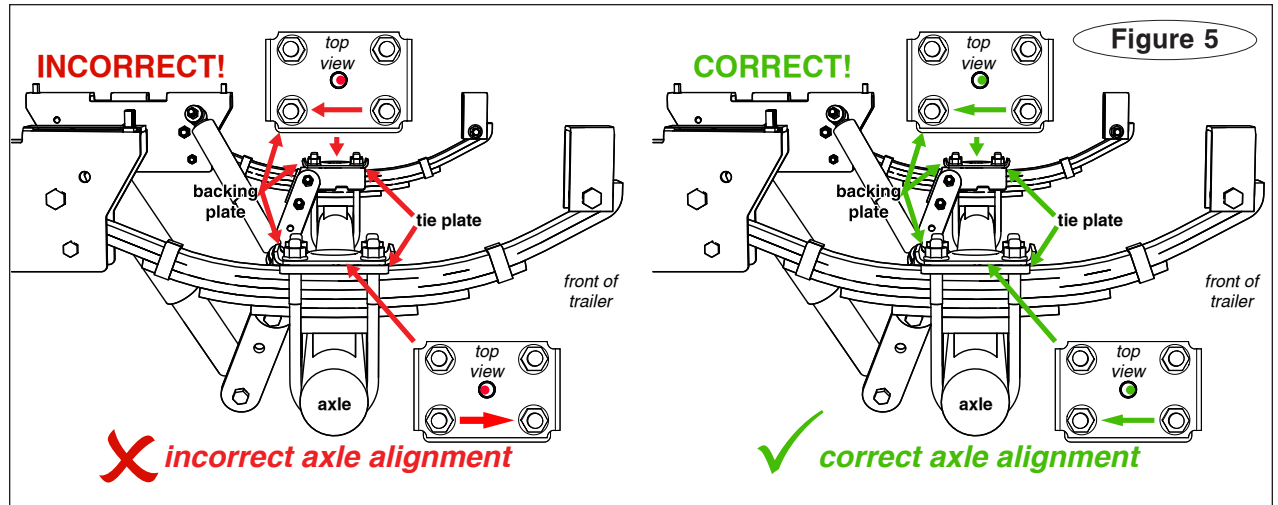
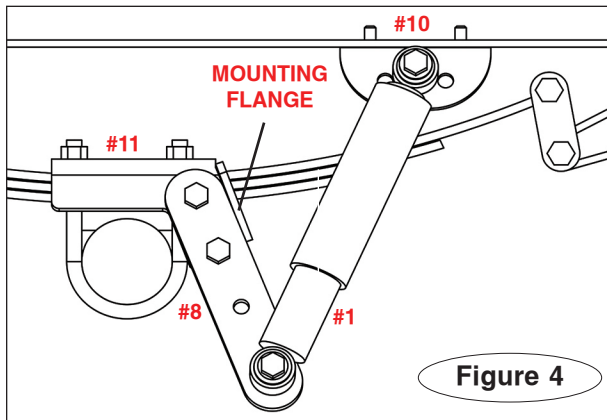
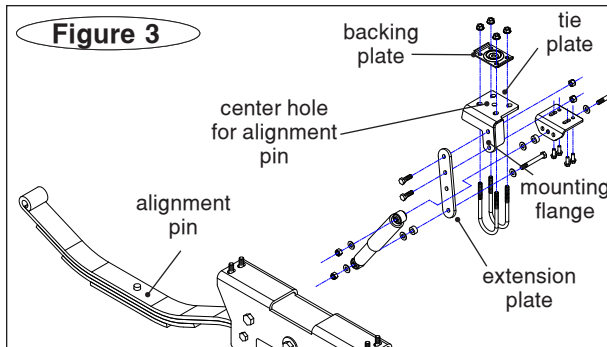

3a. Install the new U-bolts through the tie plate then through the backing plate (Figure 3 & 5). This will add additional strength to the assembly, finger tighten the U-bolt nuts.

IMPORTANT! When installing the tie plates, position the axle so that the alignment pins (shown in green, Figure 5) are seated against the tie plate (top view, Figure 5). Verify that it is the same on both sides AND on both axles. Failure to align the pins in this manner may result in an out-of-alignment axle, causing non-warranty tire wear.

3b. Repeat steps 1 through 3a for the other three tie plates. Once the axle is positioned as described above, torque all U-bolts to 130 lb-ft.

Install the Extension Plates

4. If the axle is underneath the leaf spring: Bolt the extension plate (#8) to the tie plate's mounting flange using the two hole in the extension plate (Figure 6A). Insert two bolts (#3) into the two holes in the extension plate, bolt through the mounting flange and finish with two nuts (#4). Torque to 57 ft-lb.

If the axle is on top of the leaf spring: use the same hardware but bolt through the two middle holes of the extension plate instead (Figure 6B).

CAUTION

Make sure the extension plate doesn't extend below the level of the wheel rim. If it does, the plate or the shock could be damaged in the event of a flat tire. Other consequential, non-warranty damage may also occur.

continued on next page

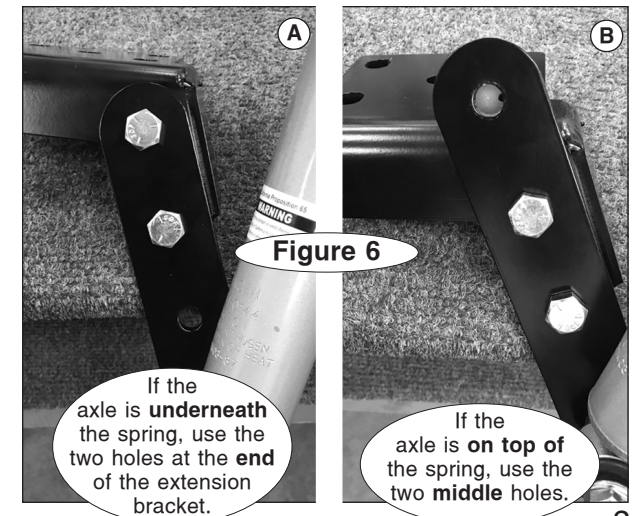



Figure 7

Mount the Shock to the Extension Plate

5. Place a washer (#5) over the bolt (#6) and then bolt through the extension plate (#8), spacer (#9), washer (#5) and the smaller end of the shock (#1). Finish with a washer (#5) and nut (#7). Finger-tighten.

Mount the Shock to the Frame Bracket

6. Position a washer (#5) over a bolt (#6) and bolt through the center hole of the frame bracket (#10), spacer (#9), washer (#5) and the top of the shock (Figure 7).

7. Finish with a washer (#5) and nut (#7). Finger-tighten for now.

Determine the Shock Angle

8. At this point, the restraining band on the shock should still be in place, retaining its fixed length of 14½” from eye-to-eye. Its length dictates where the frame bracket is to be positioned on the trailer’s frame.

CAUTION

The shocks must be restrained at a 14½” length, as described above, in order to position the frame brackets correctly. Otherwise the shocks will fail. Other consequential, non-warranty damage may also occur.

If the restraining bands on the shock absorbers have been damaged or cut, restrain the shock absorbers at a 14½” length.

9. Swing the shock and frame bracket up to the bottom of the frame and measure the angle at which the shock is now sitting.

Optimum trailer handling is achieved when the shock is at approximately a 30-degree angle. On some trailers, due to design characteristics, you may not be able to achieve this exact angle. Any angle between 20-40 degrees from vertical is acceptable (Figure 8).

If the angle is approximately 30 degrees, and the travel path of the shock is completely unobstructed: Proceed to step 10.

If not, continue to ‘Options to Attain Desired Shock Angle’ to ensure it is within 20-40 degrees.

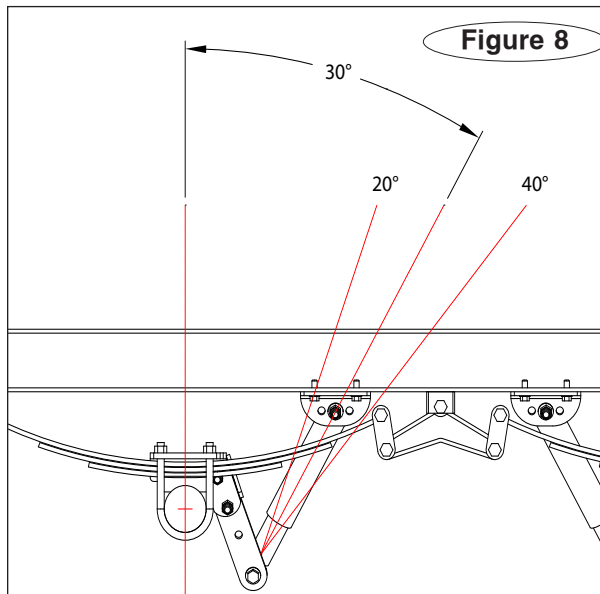

Figure 8

Options to Attain Desired Shock Angle

a. Bolt the shock to the frame bracket using the hole that best achieves the desired angle.

b. Remove the extension plate and attach the bottom of the shock to the mounting flange on the tie plate using the hole that best achieves the desired angle.

c. Drill a new hole in the extension plate to accommodate the bottom of the shock. Choose a location for this hole that will achieve the desired angle.

Mount the Frame Bracket

10. Position the frame bracket on the bottom of the frame and mark the four frame holes. Lower the shock and frame bracket and punch the center of the holes.

CAUTION

Before drilling, ensure that critical components on the top side of the frame are not in the drilling path. You must also ensure that no components underneath the trailer (such as piping, underbelly material or wiring) will prevent bolting the frame bracket flush to the frame.

11. Use a 5/16” drill bit that is 12” long to drill through the punched holes and the frame (Figure 9).

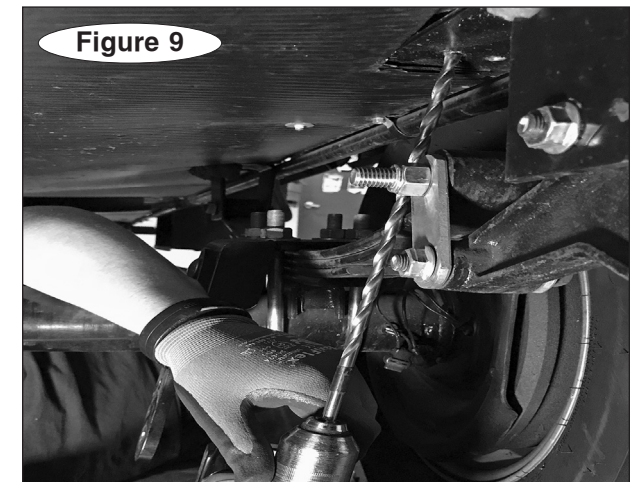

Figure 9

NOTE

If it is necessary to trim underbelly material, use a utility knife and apply repair tape or other sealing product approved by the trailer manufacturer to seal the cut.

12. Use Blue threadlocker on the four supplied self-tapping screws (#2) to secure the frame bracket to the frame. Torque the screws to 40 lb-ft.

CAUTION

Do not over torque the screws or they may fail, causing the frame bracket to separate from the frame. This may cause severe non-warranty damage if the trailer is being towed; other consequential, non-warranty damage may also occur.

The remaining bolts will be torqued in a later step.

Remove Shock Restraint

13. Cut the shock restraining strap to allow for full range of motion.

Remove the Wheels and Tires

14. At this point, removing the wheels and tires will simplify the rest of the installation.

CAUTION

Don't lift the trailer by the axles. Doing so could adversely affect the alignment of the axles or result in a bent or otherwise damaged axle.

Mount the Remaining Frame Brackets

15. The positioning of the frame bracket on the first corner of the vehicle informs us as to the location for the three remaining corners.

16. Measure the distance from the installed frame bracket to the equalizer hanger (Figure 10). Now, replicate those measurements on the other three corners. Install the remaining three frame brackets on the bottom of the frame by repeating steps 10 through 12 on each corner.

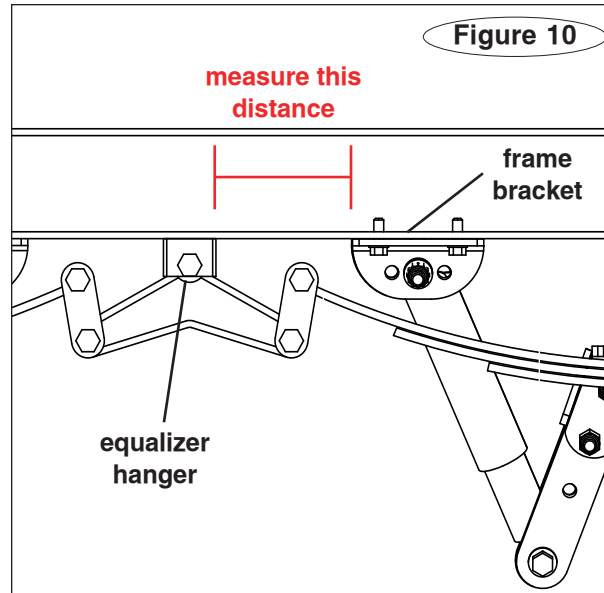

Mount the Remaining Tie Plates and Extension Plates

17. Repeat steps 1 through 4 to install the three remaining tie plates and extension plates on each corner.

Mount the Remaining Shocks

18. With the trailer suspended, the distance between the frame bracket and the tie plate will be significantly different. As such, it is necessary to cut the bands on the three remaining shocks now in order to adequately span the distance between the frame brackets and the extension plates.

19. Secure the bottom of each shock to its respective extension plates by repeating step 5.

20. Repeat steps 6 and 7 to secure the shock to the frame bracket on each corner.

Torque the Bolts

21. Now, make certain that all of the fasteners have been torqued. Refer to the torque chart below for each set of fasteners used in this installation.

Fastener Size	Torque Value
3/8" screws (#2)	40 lb-ft
1 1/2" bolts (#3)	57 lb-ft
100mm bolts (#6)	55 lb-ft
U-bolts	130 lb-ft

Reinstall the Wheels and Tires

22. Now, replace the wheels and tires and test drive the vehicle.

23. **IMPORTANT!** The U-bolts and leaf-spring stack will "settle" as the trailer is used. This settling slightly reduces clamping force, which can allow axle movement if not corrected. **Accordingly, after the trailer has been towed 100 miles, you must check and re-torque the U-bolts to 130 lb-ft.**