



Time Tested • Time Proven

856467-00 11-23

Stinger replacement kit

Part Number 910500 and 910510

Installation Instructions

All specifications are subject to change without notice.

ROADMASTER, Inc. 6110 NE 127th Ave. Vancouver, WA 98682 800-669-9690 Fax: 360-735-9300 www.roadmasterinc.com

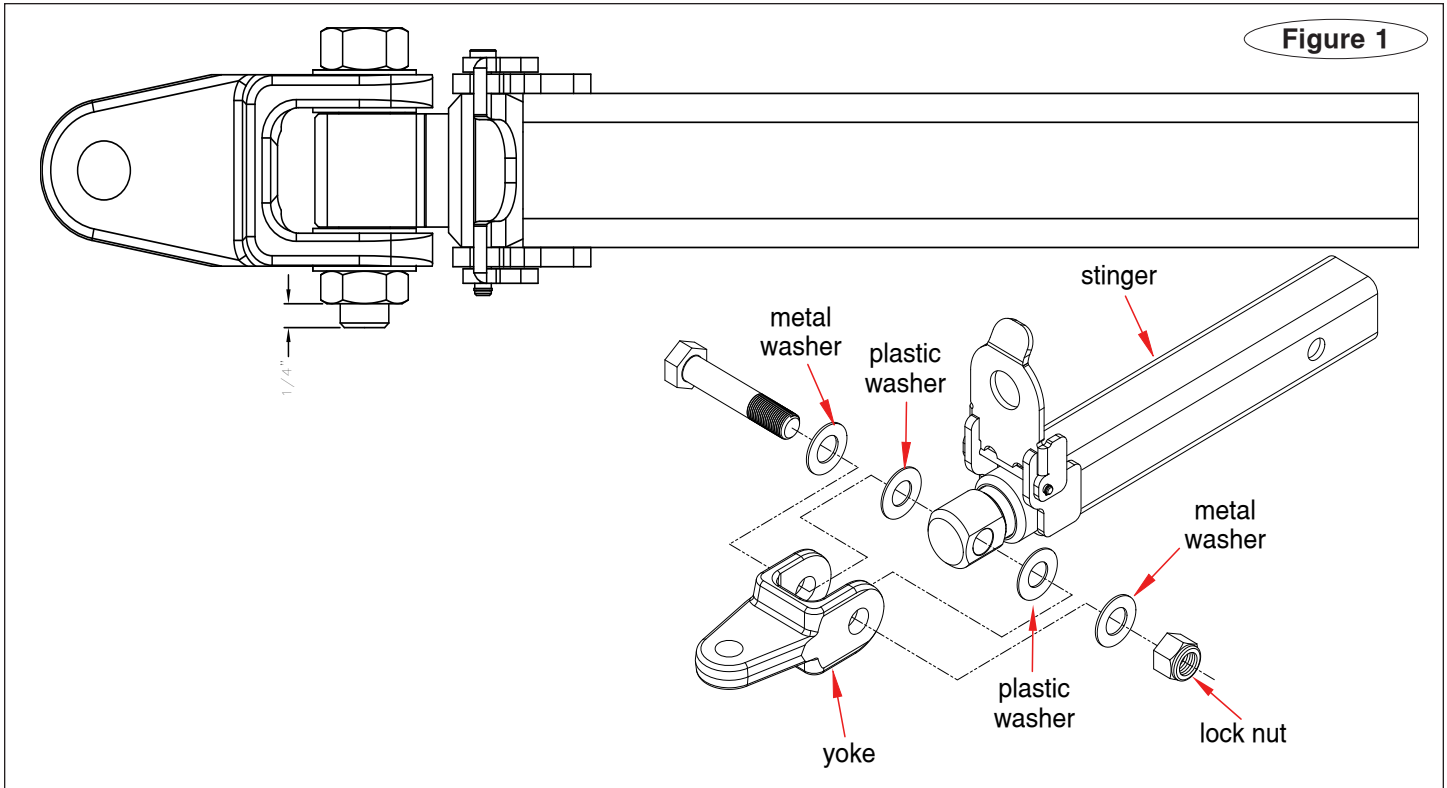

Figure 1

WARNING

Read the instructions before installing the kit components. Failure to follow these instructions may result in property damage, serious personal injury or even death.

Kit components

This kit contains the components to replace the stinger on your Falcon 2 or Falcon All Terrain tow bar.

- (2) plastic washers
- (1) stinger assembly
- (1) lock nut
- (1) Loctite 262

You will retain the 3/4" x 3" bolt and 3/4" metal flat washers from the existing stinger and yoke on the tow bar.

Required tools

- (2) 1-1/8" wrenches or sockets, OR
- (1) 5/8" Allen or hex wrench

Note: The tool you need will depend upon the existing bolt head in your tow bar.

Installation instructions

1. Remove the bolt that secures the stinger to the yoke. Retain the 3/4" metal flat washers and the 3/4" x 3" bolt, as they will be used to install the new stinger.

2. Loosely assemble the new parts (except the lock nut) using Figure 1 above as a reference. *Note: The plastic washers fit between the yoke and the stinger while the metal washers go on the outside of the yoke. Apply Loctite to the threads.*

Important! Make certain you use the new lock nut and the included Loctite when assembling the new stinger. Re-use of the old lock nut may result in failure.

3. Thread the lock nut onto the bolt and tighten the assembly. There should be approximately 1/4" of thread beyond the lock nut. The stinger should still pivot but with resistance.