

COMFORT RIDE
SUSPENSION
SYSTEM



INSTALLATION INSTRUCTIONS

Comfort Ride 2500-678

Slipper spring system (Springs Sold Separately)
required shock absorber system (sold separately)

Need Help? Call Toll-Free
 1-800-669-9690

REQUIRED TOOLS

- General hand tools
- 21/64" drill bit
- Torque wrench, 7/8" Wrench & Sockets
- Threadlocker Red
- Center punch

IMPORTANT!

Select the right springs to match the true load of your vehicle! Choosing the correct spring rating is critical. Either too light, or too heavy of springs, will negate the benefits of the Comfort Ride system. Ideally, choose a spring rating that just exceeds the actual weight on the axles. Don't jump to a heavier spring, if it isn't necessary. Doing so will create a harsh, uncomfortable ride like that of an unloaded one-ton truck. Conversely, springs rated too low for your loaded weight can fail causing non-warranty damage.

To determine the proper rating, visit a truck scale with your trailer fully loaded to verify how much weight is actually on the axles. Use springs rated just above your real-world axle loads. For example, if your trailer has two 8K axles (16k total) but the load on the axles is only 13,600 lbs, then use our 7k spring kit (designed to carry up to 14k total).

WARNING

IMPORTANT: DO NOT USE THIS KIT IF THE LOADED WEIGHT EXCEEDS:

- 10k LBS for the 5k Springs**
- 12K LBS for the 6k Springs**
- 14k LBS for the 7k Springs**
- 16k LBS for the 8k Springs**

Regardless of the axle capacity, using springs rated less than the loaded trailer weight will result in non-warranty damage to the springs.

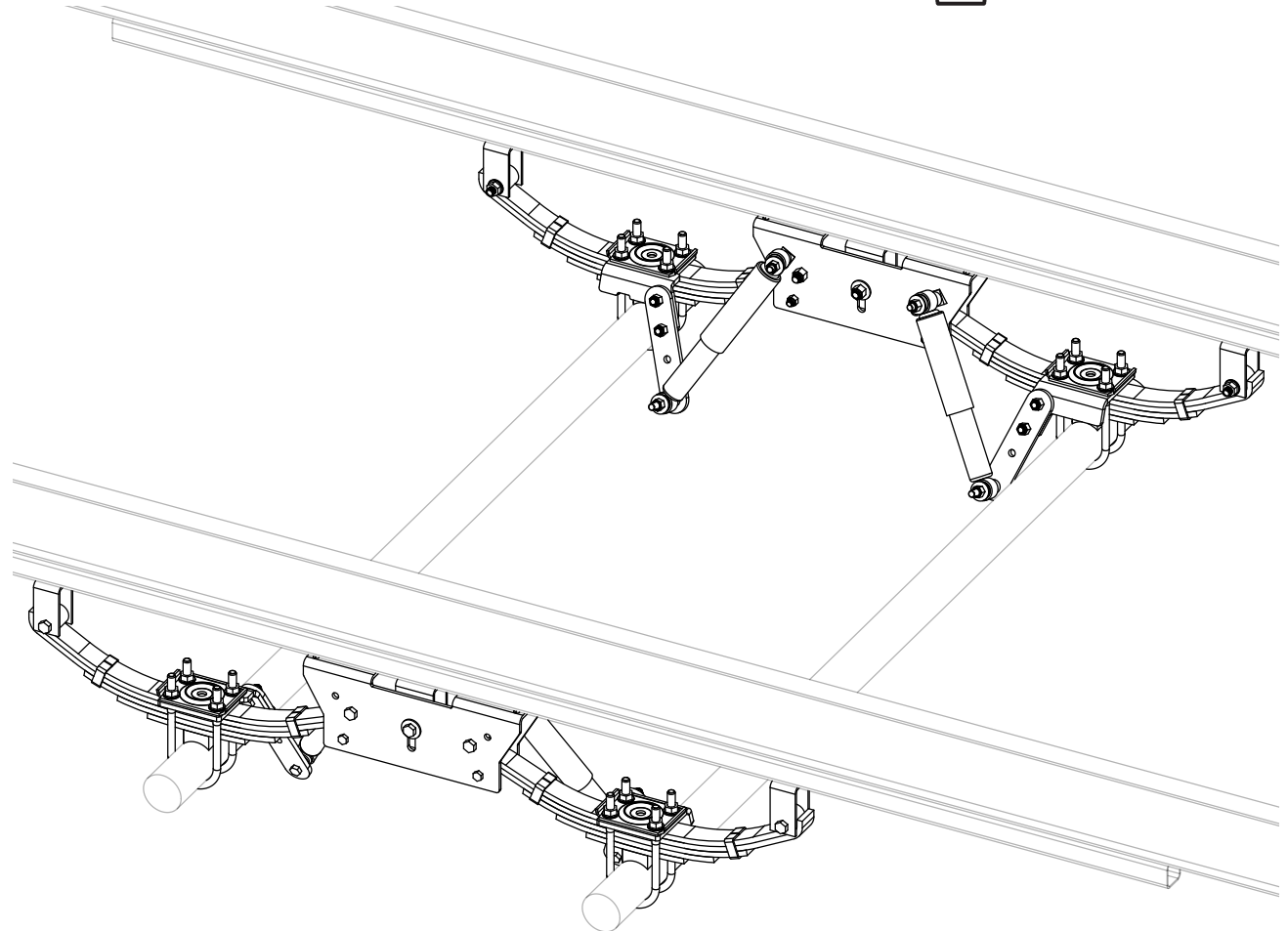

ROADMASTER, Inc. • 6110 N.E. 127th Ave.
Vancouver, WA 98682

⚠ WARNING



Read all instructions before you install this product. Failure to understand how to install this product could result in property damage, personal injury or even death.

Note: If you're a professional installer, please give these instructions to the customer once the kit is installed.

Note: For ease of installation, the shock absorbers (sold separately) are shipped with restraining bands to hold them at a specific length. Don't remove the restraining bands until instructed to do so.

All illustrations and specifications contained herein are based on the latest information available at the time of publication approval. ROADMASTER, INC. reserves the right to make changes at any time without notice in material, specification and models or to discontinue models.

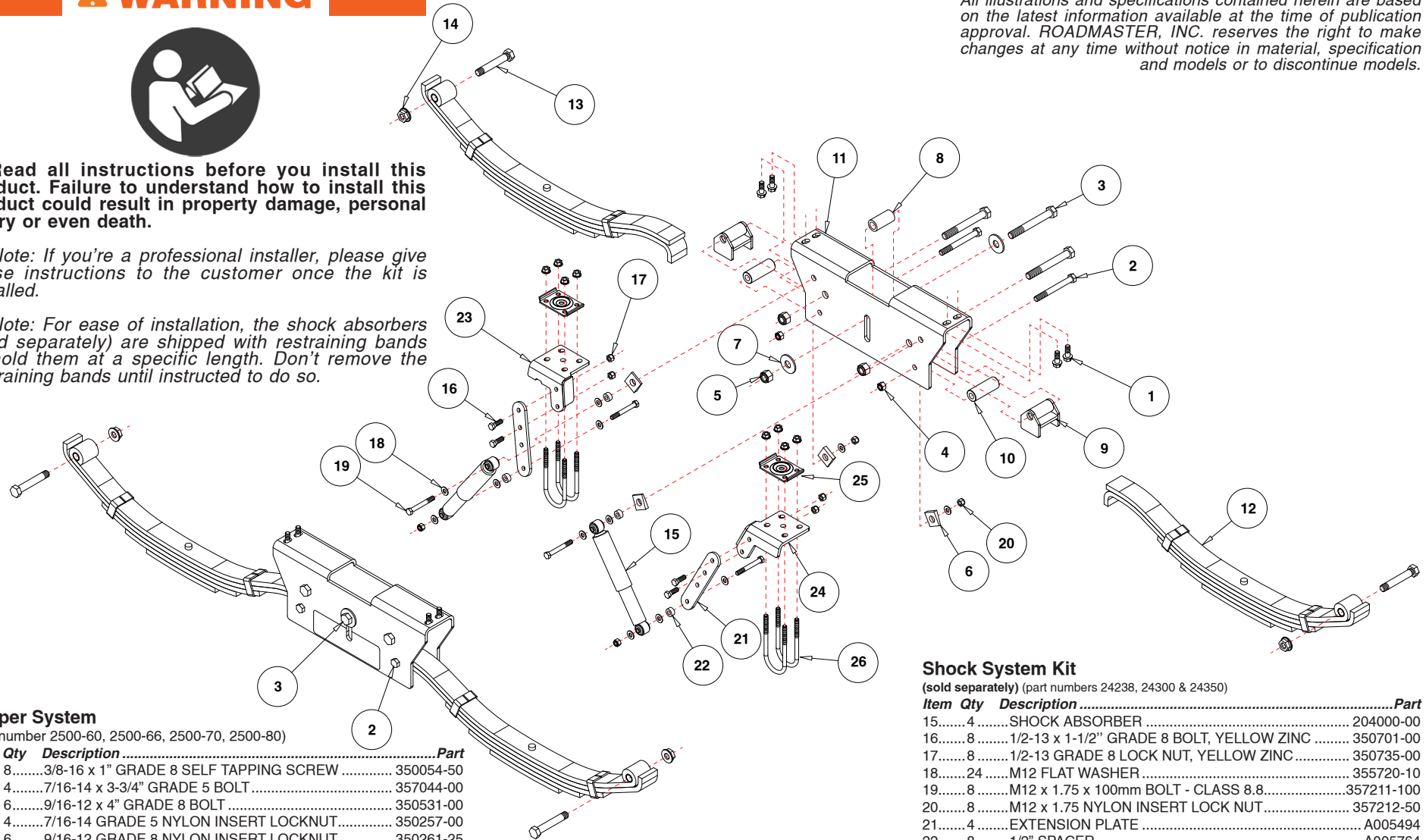

Slipper System

(part number 2500-60, 2500-66, 2500-70, 2500-80)

Item	Qty	Description	Part
1	8	3/8-16 x 1" GRADE 8 SELF TAPPING SCREW	350054-50
2	4	7/16-14 x 3-3/4" GRADE 5 BOLT	357044-00
3	6	9/16-12 x 4" GRADE 8 BOLT	350531-00
4	4	7/16-14 GRADE 5 NYLON INSERT LOCKNUT	350257-00
5	6	9/16-12 GRADE 8 NYLON INSERT LOCKNUT	350261-25
6	8	WEDGE WASHER	350308-50
7	4	9/16" GRADE 8 FLAT WASHER	350347-20
8	2	1" O.D. x 0.625" I.D. x 1 3/4" SPACER	A005071
9	4	WEAR PAD	C003558
10	4	3/4" O.D. x 0.500" ID. x 2 1/2" SPACER	A006291
11	2	SLIPPER SPRING BOX	B004008
12	4	5K LEAF SPRING FOR 2500-60 (Sold Separately)	220023-20
	4	6K LEAF SPRING FOR 2500-66 (Sold Separately)	220025-60
	4	7K LEAF SPRING FOR 2500-70 (Sold Separately)	220024-50
	4	8K LEAF SPRING FOR 2500-80 (Sold Separately)	220025-50
13	4	SPLINED BOLT	350216-70
14	4	9/16-18 FLANGED LOCKNUT	350216-75

Shock System Kit

(sold separately) (part numbers 24238, 24300 & 24350)

Item	Qty	Description	Part
15	4	SHOCK ABSORBER	204000-00
16	8	1/2-13 x 1-1/2" GRADE 8 BOLT, YELLOW ZINC	350701-00
17	8	1/2-13 GRADE 8 LOCK NUT, YELLOW ZINC	350735-00
18	24	M12 FLAT WASHER	355720-10
19	8	M12 x 1.75 x 100mm BOLT - CLASS 8.8	357211-100
20	8	M12 x 1.75 NYLON INSERT LOCK NUT	357212-50
21	4	EXTENSION PLATE	A005494
22	8	1/2" SPACER	A005764
23	2	TIE PLATE FOR 2 3/8" AXLE-2450	C003264
	2	TIE PLATE FOR 3" AXLE-2460	C003169
	2	TIE PLATE FOR 3 1/2" AXLE-2470	C003294
24	2	TIE PLATE FOR 2 3/8" AXLE-2450	C003265
	2	TIE PLATE FOR 3" AXLE-2460	C003170
	2	TIE PLATE FOR 3 1/2" AXLE-2470	C003295
25	4	U-BOLT BACKING PLATE FOR 2 3/8" AXLE	B004231
	4	U-BOLT BACKING PLATE FOR 3" AXLE	B004229
	4	U-BOLT BACKING PLATE FOR 3 1/2" AXLE	B004230
26	8	9/16" X 2 3/8" U-BOLT WITH NUTS	357448-00
	8	9/16" X 3" U-BOLT WITH NUTS	357446-00
	8	9/16" X 3 1/2" U-BOLT WITH NUTS	357447-00

Before Installation...

CAUTION

If you are installing this kit on a triple axle trailer, refer to the instructions that came with that kit before proceeding with this installation.

Please also note that the leaf springs are to be used only in conjunction with a Comfort Ride shock absorber system. Don't install the leaf springs by themselves.

• If the shock kit does not include new U-bolts, ensure that the U-bolts attaching the trailer's leaf springs to the axles have at least $\frac{3}{4}$ " of thread showing beyond the nut (Figure 1).

Note: If you need longer U-bolts, *You will need one kit per axle;*

- order **part 26238** for 2-3/8" axles
- order **part 2630** for 3" axles
- order **part 2635** for 3-1/2" axles

• Check for under-vehicle obstructions near the trailer's suspension (such as plumbing, wiring or other trailer components) that may prevent the installation of the product. It may be necessary to modify or relocate components in order to install this product.

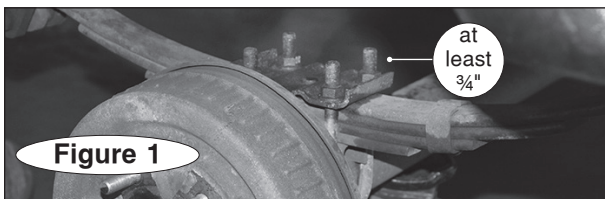

Installation

1. Lift the trailer by the frame so that the suspension hangs. Ensure the trailer is level at all four corners.

CAUTION

Don't lift the trailer by the axles. Doing so could adversely affect the alignment of the axles or result in a bent or otherwise damaged axle.

2. Remove the wheels and tires.
3. Support all axles at both ends with stands. Position the stands at the ends of each axle, not in the middle.
4. Detaching the axles from the springs:
 - a. Test to see if the axle U-bolts can be removed. If they cannot, soak them in a quality penetrating oil.
 - b. Ensure that the trailer brake wiring will not be damaged when the axles are detached from the springs.
 - c. Detach the axles from the springs by removing the axle U-bolts and tie plates (Figure 2). Keep the hardware for re-installation.
5. How to remove the spring hanger bolts (Figure 3):

CAUTION

Do not attempt to turn the spring hanger bolt heads. On many trailers, these are splined bolts. If you turn the bolt head, the bolt may break and/or the spring hanger flanges may be damaged.

Follow the instructions below to remove them.

- a. Remove the spring hanger nuts from the bolts.
 - b. Use a C-clamp or similar device to secure the spring hanger flanges to each other so they don't bend when the bolt is driven out.
 - c. Position a center punch or similar device on the end of the bolt and hammer the center punch to drive the bolt out.
 - d. Repeat for the other side of the trailer.
6. Remove the leaf springs and the equalizer assembly.
 7. Ensure that the center equalizer hanger flanges are straight and vertical. If necessary, bend them (Figure 4).
 8. Installing the slipper spring box:
 - a. Insert one of the included 2-1/2" pipe spacers between the flanges of the center equalizer hanger (Figure 5).

continued on next page

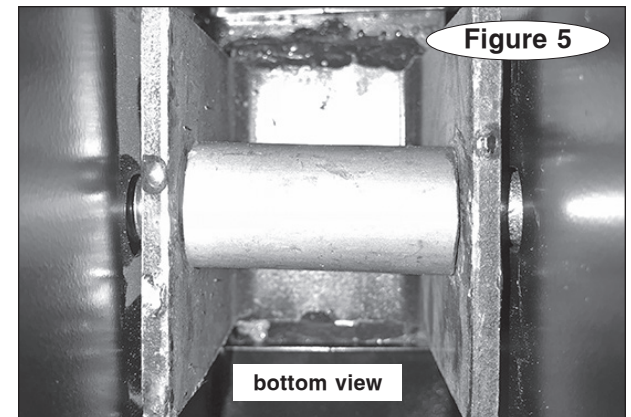
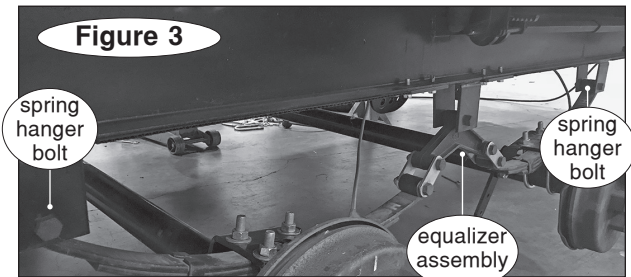
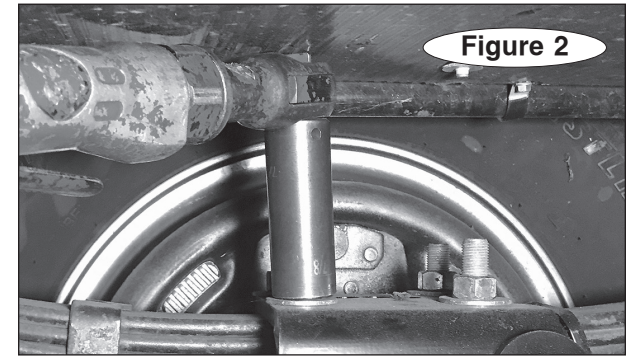

continued from preceding page

b. With the sticker (Figure 6) facing the outside of the trailer, slide the slipper spring box up and over the equalizer hanger bracket. Align the central slotted hole on the slipper spring box to the hole in the equalizer hanger bracket.

c. The slipper spring box must sit flush against the bottom of the frame. Check for obstructions such as underbelly material, plumbing, etc. and remove or reposition them.

Note: If it's necessary to trim underbelly material, use a utility knife and apply repair tape or other sealing product approved by the trailer manufacturer

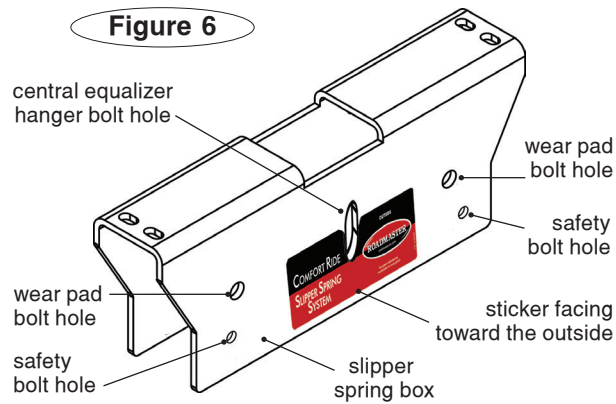

to seal the cut.

d. Position a 9/16" flat washer over one of the included 9/16" x 4" bolts and insert it through the central hole in the slipper spring box and the 1 3/4" pipe spacer. On the opposite side of the slipper spring box, finish with another 9/16" flat washer and 9/16" nylock nut. Leave loose at this time.

Figure 7 shows the slipper spring box.



9. Align the slipper spring box so that it is in line with the trailer's frame rail and centered underneath the frame rail.

Using the preexisting holes in the top of the slipper spring box as templates, mark and drill four 21/64" diameter holes through the frame rail (Figure 8).

Tech tip: Start your first hole with a small self-drilling screw rather than a drill bit. Use the screw to keep the slipper box centered and properly aligned while you drill the rest of the holes. Don't forget to replace it with one of the included 3/8" self-tapping screws once all the holes have been drilled (step 10).

10. Use four of the included 3/8" self-tapping screws to attach the slipper spring box to the frame using the holes you just drilled. Use threadlocker on the screws; tighten to 40 lb-ft.

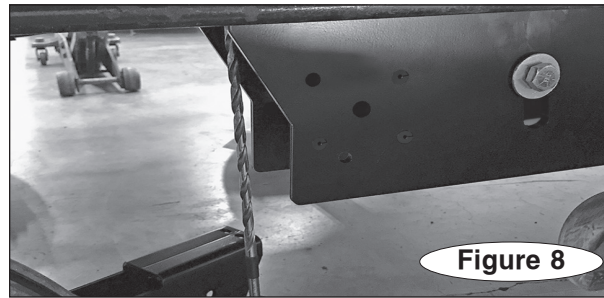

CAUTION

Do not over torque the screws or they may fail, causing the slipper spring box to separate from the frame. This may cause severe non-warranty damage if the trailer is being towed; other consequential, non-warranty damage may also occur.

11. Repeat steps 6 through 10 for the opposite side.

12. Installing the new slipper springs (refer to Figure 6 for the bolt locations in steps 12 and 13):

a. Insert the eyelet end of the spring between the flanges of the spring hanger and install the new splined spring eye bolts included with this kit. Drive the bolt home using a hammer to fully engage the splines.

b. Using a cleaner/degreaser, clean and dry the threads on the end of the bolt. Apply threadlocker red (not included) before proceeding to 12c.

c. Install the a new nut on the spring hanger bolt.

d. Tight the spring bolt nut (Figure 9).

Ensure that the spring can still pivot freely inside the hanger.

e. Repeat for all other springs on the trailer.

Note: The slipper ends of each spring are always inside the slipper spring box; the spring eyelets don't go inside the slipper spring box.

13. Installing the safety bolts:

a. Pivot the slipper spring up until it's inside the

WARNING

The spring bolts must be tightened so that the spring hanger hole rides on the shoulder of the bolt. If the spring hanger hole rides on the threads, the bolt will eventually fail causing severe, non-warranty damage.

slipper spring box. Move the slipper end until both ends of the spring are approximately level with each other.

b. Insert a 7/16" bolt through the safety bolt hole (refer to Figure 6), a 2 1/2" pipe spacer, and then through the other side of the slipper spring box.

The slipper spring should now be resting on the pipe spacer (Figure 10).

Finish with a 7/16" nylock nut and torque to 40 lb-ft.

Before proceeding, torque the central 9/16" bolt and nut you installed in step 8d to 54 lb-ft.

c. Repeat steps 12 and 13 for all other springs on the

continued on next page

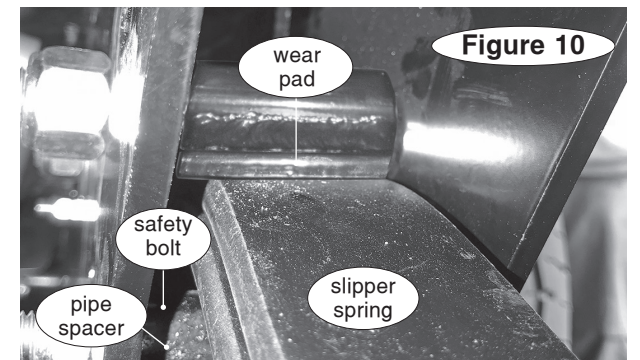
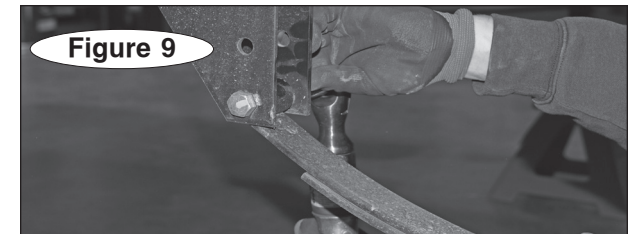

continued from preceding page

trailer.

14. Installing the wear pads (Figure 10):

a. Use the wear pad bolt hole for mounting the wear pad (Figure 11).

b. Position the wear pad inside the slipper spring box and insert a 9/16" x 4" bolt through the wear pad bolt hole, through the wear pad, and then out the other side. Finish with a 9/16" nylock nut.

Note: When positioned correctly, the wear pad will be above the end of the leaf spring. The spring will contact the wear pad once the suspension is loaded (Figure 10).

Torque the bolt to 54 lb-ft. Don't over-tighten the bolt but ensure that the wear pad still moves freely.

c. Repeat step 14 for the three remaining wear pads.

15. Install the Comfort Ride Shock Absorbers:

a. Position the tie plate so that the alignment pin on the leaf spring engages the center hole in the tie plate (Figures 12 and 13). Ensure the shock mounting flange faces toward the center of the trailer and is positioned between the axles. Refer to the drawing on page 1 to better understand how the parts attach to each other.

b. Install the U-bolts through the tie plate and included backing plate; finger tighten the U-bolt nuts.

IMPORTANT! When installing the tie plates, position the axle so that the alignment pins (shown in green, Figure 13) are seated against the tie plate (top view, Figure 13). Verify that it is the same on both sides AND on both axles. Failure to align the pins in this manner may result in an out-of-alignment axle, causing non-warranty tire wear.

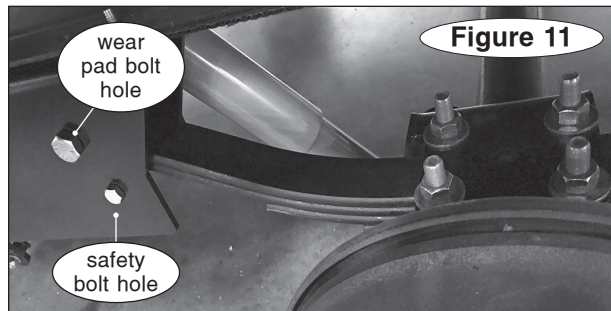

Once the axle is positioned as described above, torque all U-bolts to 130 lb-ft.

c. Repeat this process for all tie plates and U-bolts.

16. Reinstall the wheels and tires, remove all jack

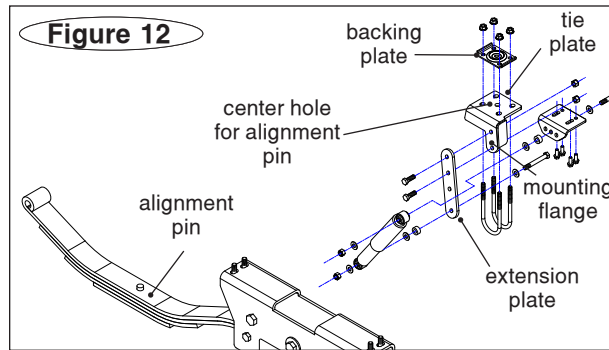

stands and lower the trailer to load the suspension.

Note: If the trailer has the Correct Track system, check to see if it needs adjustment to align the axles after this installation.

CAUTION

Ensure the suspension is fully loaded, i.e., bearing the weight of the trailer, before installing the shock absorbers. Otherwise, the shock absorbers will be the wrong length once installed. The shock absorbers and trailer may be damaged. Other collateral, non-warranty damage may also occur.

17. Installing the shock absorbers to the slipper spring boxes (Figure 14):

a. Place a 12mm washer over a 12mm x 1.75 x

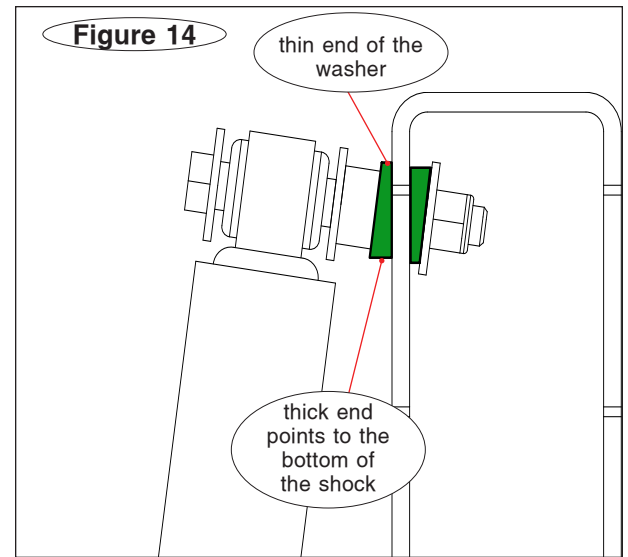

100mm bolt. Bolt through the top of the shock absorber, 12mm washer, a spacer, wedge washer (in green) and the slipper spring box. *Note: The wider portion of the shock absorber body should point to the top.*

b. Finish with another wedge washer (in green), 12mm flat washer and 12mm nylock nut.

c. Tighten the 12mm bolt and nut just enough so that the wedge washers will stay in place when you rotate them. (The wedge washers will be rotated, and the shock mounting bolts torqued, in a later step).

d. Repeat for the remaining shock absorbers.

continued on next page

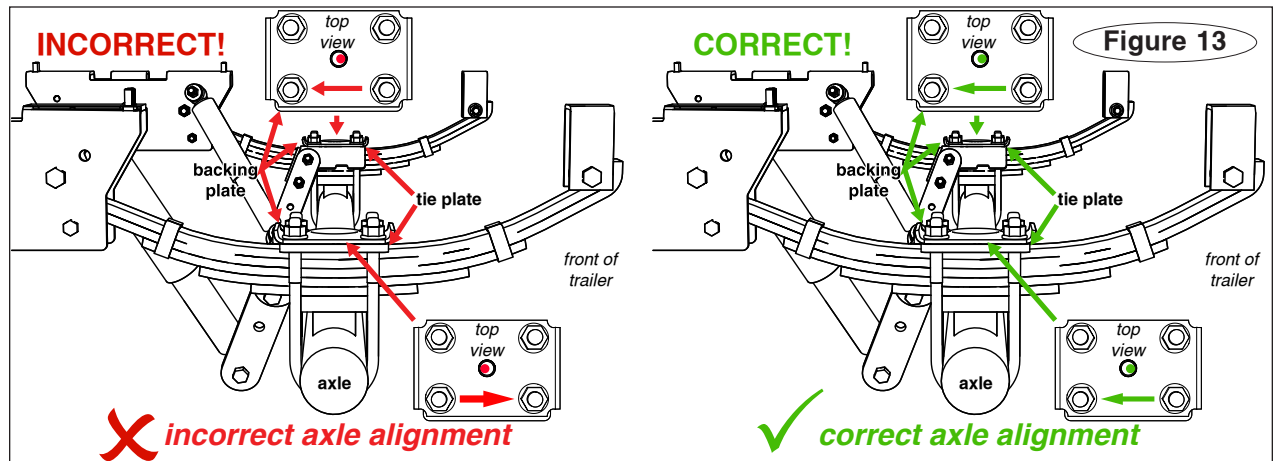

continued from preceding page

18. Mounting the shock absorbers to the mounting flanges or extension plates:

a. The purpose of the restraining bands on the shock absorbers is to hold them at a fixed length. This length will dictate where the bottom of the shock absorbers should be fastened.

NOTE

If the restraining bands are damaged or cut, restrain the shock absorbers at a 14½" length, hole-center to hole-center.

I. The final mounting location must be between 20 and 40 degrees (Figure 16).

II. Determine which option shown in Figure 15 places the bottom hole of the shock absorber closest to a mounting hole. If A or B, secure the extension plate with the provided yellow zinc grade 8 bolts and locknuts. It is important that the shocks are attached to the closest hole to their restrained 14-1/2" length;

III. If the existing drilled options do not align, use the shock absorber as a template and drill a new hole to accommodate it. It is **critically important** to ensure that any hole you drill is at least ½" away from any other hole.

CAUTION

Make sure the shock absorber extension plate doesn't extend below the level of the wheel rim. If it does, the plate or the shock absorber could be damaged in the event of a flat tire. Other consequential, non-warranty damage may also occur.

b. Position a 12mm washer over one of the included 12mm x 1.75 x 100mm bolts. Bolt through the extension plate, a spacer, 12mm washer and the bottom of the shock absorber. Finish with another 12mm washer and a 12mm nylock nut. Leave loose at this time.

c. Repeat for the remaining shock absorbers.

19. Referring to the drawing in Figure 14, verify the wedge washer orientation:

a. On the **INSIDE** of the slipper box, rotate the wedge washer so that the thin end points **DOWN**, in line with the body of the shock.

b. On the **OUTSIDE** of the slipper box, rotate the wedge washer so that the thick end points **DOWN**, in line with the body of the shock.

NOTE

The wedge washers provide a flat surface for mounting the shock while spacing the shock away from the slipper spring box.

CAUTION

If the wedge washers aren't positioned as described above, the shock absorbers may be damaged. Other collateral, non-warranty damage may also occur.

c. Tighten all top and bottom shock absorber mounting bolts to 55 lb-ft. Now, remove the restraining bands from the shock absorbers.

Re-check the torque of all fasteners. All bolts should be tight.

20. IMPORTANT! The U-bolts and leaf-spring stack will "settle" as the trailer is used. This settling slightly reduces clamping force, which can allow axle movement if not corrected. Accordingly, **after the trailer has been towed 100 miles, you must check and re-torque the U-bolts to 130 lb-ft.**

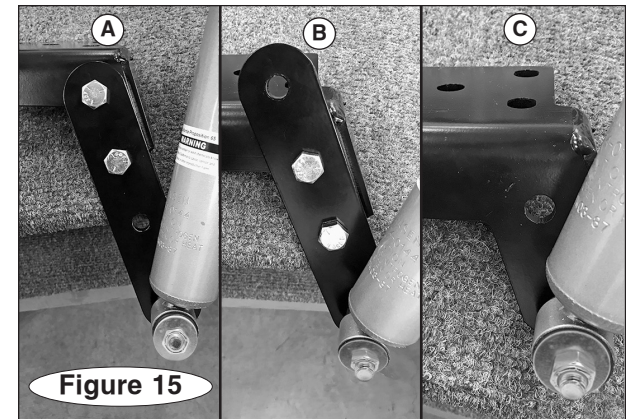

Figure 15

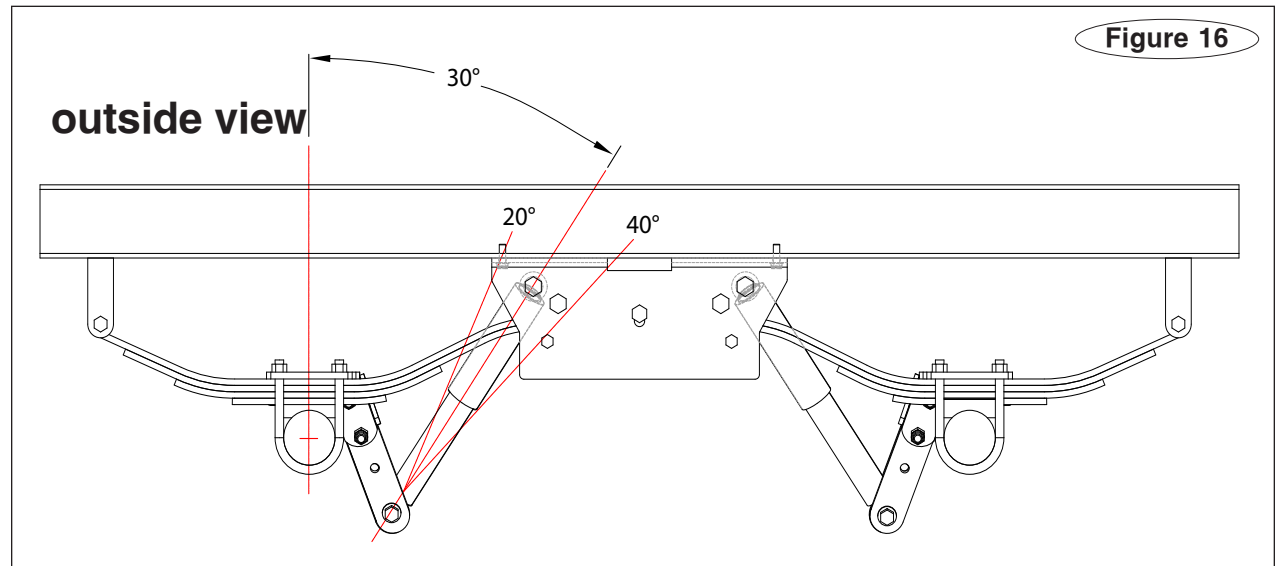

Figure 16