

Third Axle Slipper Spring Kit (parts 2503-60, 2503-66, 2503-70, & 2503-80)

Item	Qty	Description	Part
1	8	3/8-16 x 1" GRADE 8 SELF TAPPING SCREW	350054-50
2	4	7/16-14 x 3-3/4" GRADE 5 BOLT	357044-00
3	6	9/16-12 x 4" GRADE 8 BOLT	350531-00
4	4	7/16-14 GRADE 5 NYLON INSERT LOCKNUT	350257-00
5	6	9/16-12 GRADE 8 NYLON INSERT LOCKNUT	350261-25
6	4	WEDGE WASHER	350308-50
7	4	9/16" GRADE 8 FLAT WASHER	350347-20
8	2	1" O.D. x 0.625" I.D. x 1 3/4" SPACER	A005071
9	2	WEAR PAD	C003558
10	4	3/4" O.D. x 0.500" ID. x 2 1/2" SPACER	A006291
11	2	SLIPPER SPRING BOX	B004008
12	2	5K LEAF SPRING FOR 2500-60 (sold separately)	220023-20
	2	6k LEAF SPRING FOR 2500-66 (sold separately)	220025-50
	2	7k LEAF SPRING FOR 2500-70 (sold separately)	220024-50
	2	8k LEAF SPRING FOR 2500-80 (sold separately)	220025-50
13	2	ANTI-ROTATION PLATE	A005873

Shock System Kit (sold separately) (part numbers 24238, 24300 & 24350)

Item	Qty	Description	Part
14	4	SHOCK ABSORBER	204000-00
15	8	1/2-13 x 1-1/2" GRADE 8 BOLT, YELLOW ZINC	350701-00
16	8	1/2-13 GRADE 8 LOCK NUT, YELLOW ZINC	350735-00
17	24	M12 FLAT WASHER	355720-10
18	8	M12 x 1.75 x 100mm BOLT - CLASS 8.8	357211-100
19	8	M12 x 1.75 NYLON INSERT LOCK NUT	357212-50
20	4	EXTENSION PLATE	A005494
21	8	1/2" SPACER	A005764
22	2	TIE PLATE FOR 2 3/8" AXLE-2450	C003264
	2	TIE PLATE FOR 3" AXLE-2460	C003169
	2	TIE PLATE FOR 3 1/2" AXLE-2470	C003294
23	2	TIE PLATE FOR 2 3/8" AXLE-2450	C003265
	2	TIE PLATE FOR 3" AXLE-2460	C003170
	2	TIE PLATE FOR 3 1/2" AXLE-2470	C003295
24	4	U-BOLT BACKING PLATE FOR 2 3/8" AXLE	B004231
	4	U-BOLT BACKING PLATE FOR 3" AXLE	B004229
	4	U-BOLT BACKING PLATE FOR 3 1/2" AXLE	B004230
25	8	9/16" X 2 3/8" U-BOLT WITH NUTS	357448-00
	8	9/16" X 3" U-BOLT WITH NUTS	357446-00
	8	9/16" X 3 1/2" U-BOLT WITH NUTS	357447-00



Comfort Ride
Third Axle Slipper Spring Kit

(part: 2503-678)
required leaf slipper springs (sold separately)
required shock absorber system (sold separately)

INSTALLATION INSTRUCTIONS

All illustrations and specifications contained herein are based on the latest information available at the time of publication approval. ROADMASTER, INC. reserves the right to make changes at any time without notice in material, specification and models or to discontinue models.

ATTENTION

This third axle kit is designed to be used only in conjunction with Comfort Ride Slipper Spring systems for tandem axle trailers (part numbers 2500-60, 2500-66, 2500-70 and 2500-80).

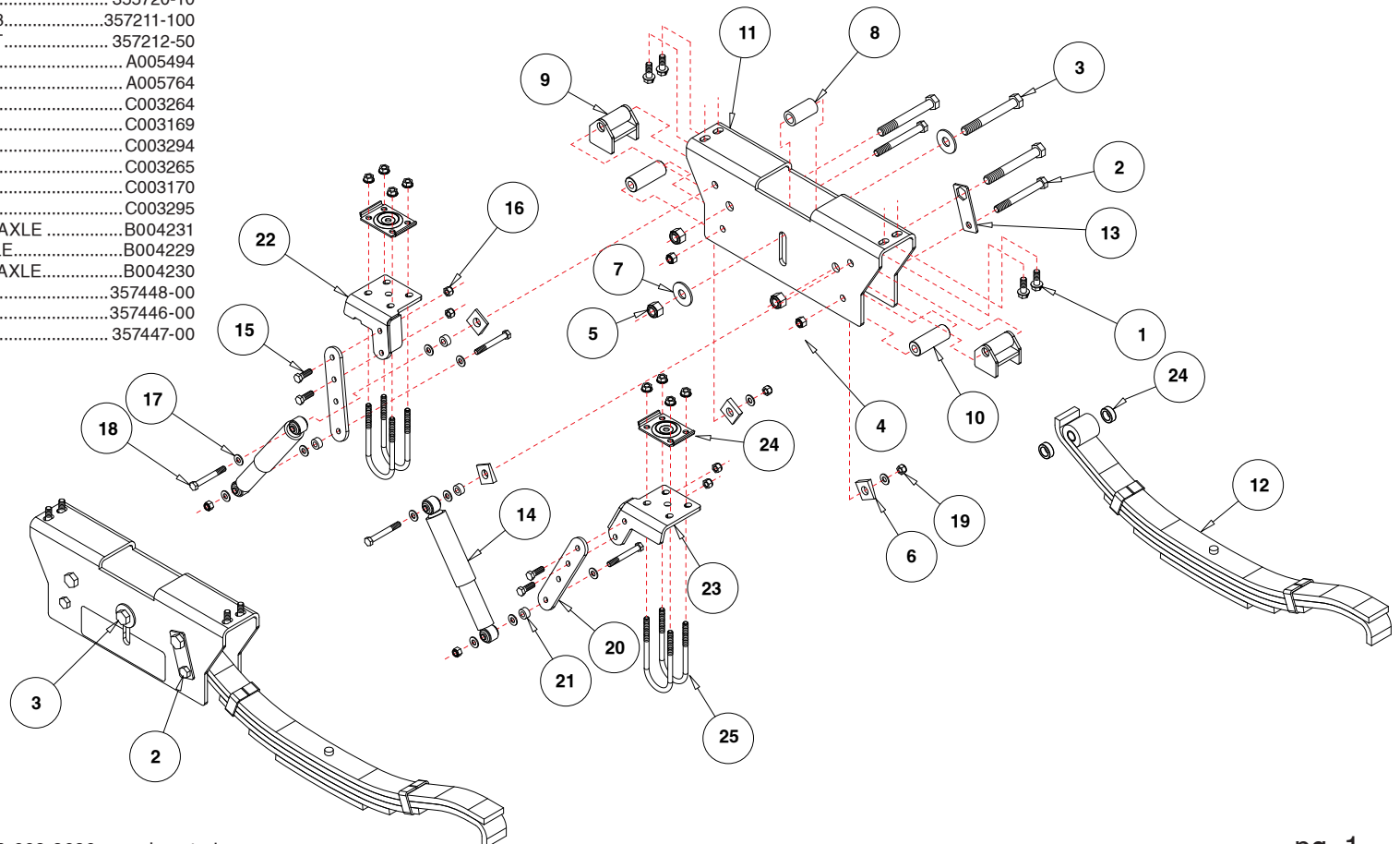

WARNING

IMPORTANT:
This kit does *not* include slipper springs.
Match the spring rating to your trailer's existing springs.



ROADMASTER, Inc. • 6110 N.E. 127th Ave.
Vancouver, WA 98682

REQUIRED TOOLS

- General hand tools
- 21/64" drill bit
- Torque wrench, 7/8" Wrench & Sockets
- Threadlocker Red
- Center punch

Need Help? Call Toll-Free
 1-800-669-9690

Before you begin the installation...

⚠ WARNING



Read all instructions before you install this product. Failure to understand how to install this product could result in property damage, personal injury or even death.

Note: If you're a professional installer, please give these instructions to the customer once the kit is installed.

Note: For ease of installation, the shock absorbers (sold separately) are shipped with restraining bands to hold them at a specific length. Don't remove the restraining bands until instructed to do so.

IMPORTANT! Select the right springs to match the true load of your vehicle! Choosing the correct spring rating is critical. Either too light, or too heavy of springs, will negate the benefits of the Comfort Ride system. Ideally, choose a spring rating that just exceeds the actual weight on the axles. Don't jump to a heavier spring, if it isn't necessary. Doing so will create a harsh, uncomfortable ride like that of an unloaded one-ton truck. Conversely, springs rated too low for your loaded weight can fail causing non-warranty damage.

To determine the proper rating, visit a truck scale with your trailer fully loaded to verify how much weight is actually on the axles. Use springs rated just above your real-world axle loads. For example, if your trailer has two 8K axles (16k total) but the load on the axles is only 13,600 lbs, then use our 7k spring kit (designed to carry up to 14k total).

IMPORTANT

If the trailer leaf spring hanger heights are 3¼" as shown in Figure 1, then proceed with installation, however:

- **If the hangers are 2¼": you must install leaf spring spacers (part 25475) on the front and rear axle, where the leaf springs connect with the axle saddle before continuing with the installation.**
- **If the hangers are any other size: you must remove the existing spring hangers and replace them with 3¼" hangers before continuing with this installation.**

It is critically imperative that the spring hangers are 3¼", otherwise the axles will be at different heights resulting in uneven tire wear and excessive forces on one or more of your axles. Other, non-warranty damage may occur.

Please also note that the leaf springs are to be used only in conjunction with a Comfort Ride shock absorber system. Don't install the leaf springs by themselves.

IMPORTANT! Select the right springs to match the true load of your vehicle! Choosing the correct spring rating is critical. Either too light, or too heavy

of springs, will negate the benefits of the Comfort Ride system. Ideally, choose a spring rating that just exceeds the actual weight on the axles. Don't jump to a heavier spring, if it isn't necessary. Doing so will create a harsh, uncomfortable ride like that of an unloaded one-ton truck. Conversely, springs rated too low for your loaded weight can fail causing non-warranty damage.

- If the shock kit does not include U-bolts, ensure that the U-bolts attaching the trailer's leaf springs to the axles have at least ¾" of thread showing beyond the nut (Figure 2).

Note: If you need longer U-bolts, order **part 26238** for 2-3/8" axles, order **part 2630** for 3" axles or **part 2635** for 3½" axles. *You will need one kit per axle.*

- Check for under-vehicle obstructions (such as plumbing, wiring or other trailer components). It may be necessary to modify or relocate components in order to install this product.

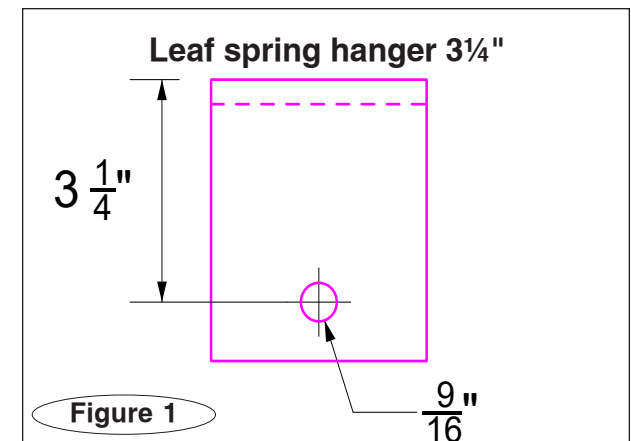

Slipper Springs only installed

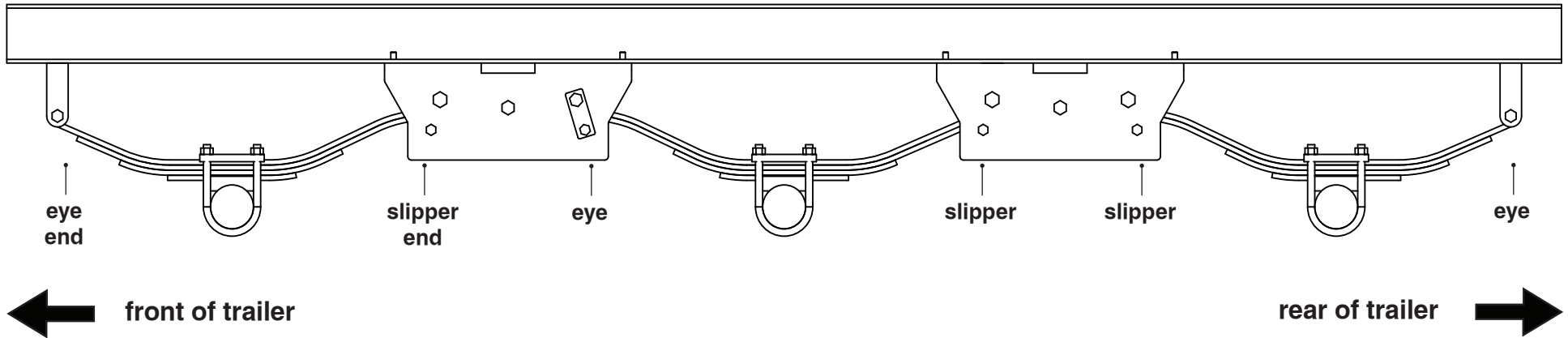

Slipper Springs and Shock Absorbers installed

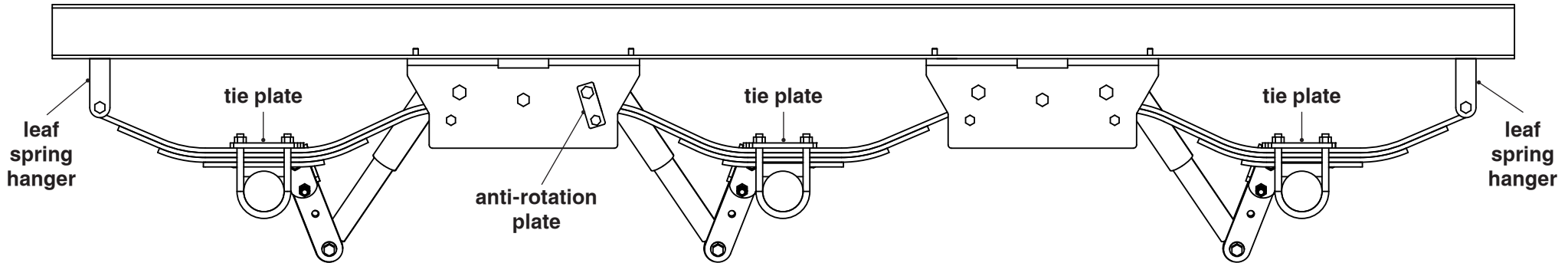

Installation

1. Lift the trailer by the frame so that the suspension hangs. Ensure the trailer is level at all four corners.

CAUTION

Don't lift the trailer by the axles. Doing so could adversely affect the alignment of the axles or result in a bent or otherwise damaged axle.

2. Remove the wheels and tires.
3. Support all axles at both ends with stands. Position the stands at the ends of each axle, not in the middle.
4. Detaching the axles from the springs:
 - a. Test to see if the axle U-bolts can be removed. If they cannot, soak them in a quality penetrating oil.
 - b. Ensure that the trailer brake wiring will not be

damaged when the axles are detached from the springs.

c. Detach the axles from the springs by removing the axle U-bolts and tie plates (Figure 4). Keep the hardware for re-installation.

continued on next page

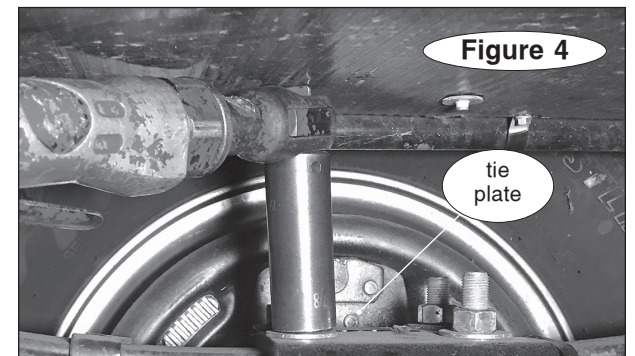
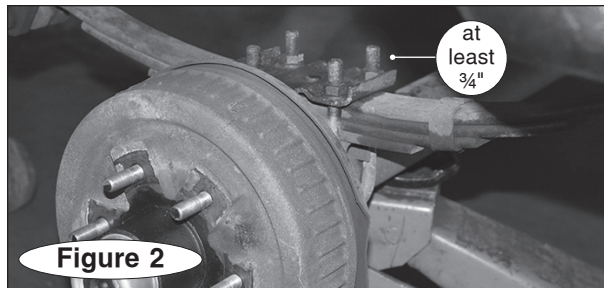

continued from preceding page

5. How to remove the spring hanger bolts (Figure 5):

CAUTION

Do not attempt to turn the spring hanger bolt heads. On many trailers, these are splined bolts. If you turn the bolt head, the bolt may break and/or the spring hanger flanges may be damaged.

Follow the instructions below to remove them.

- Remove the spring hanger nuts from the bolts.
 - Use a C-clamp or similar device to secure the spring hanger flanges to each other so they don't bend when the bolt is driven out.
 - Position a center punch or similar device on the end of the bolt and hammer the center punch to drive the bolt out. *Note: You will be reusing these bolts. For that reason, don't hammer directly on the end of the bolt, or you will deform the threads.*
 - Repeat for the other side of the trailer.
6. Remove the leaf springs and the equalizer assembly.
7. Ensure that the center equalizer hanger flanges are straight and vertical. If necessary, bend them (Figure 6).



8. Installing the slipper spring box:

a. Insert one of the included 2-1/2" pipe spacers in the center equalizer hanger flanges located between the front and middle axle (Figure 7).

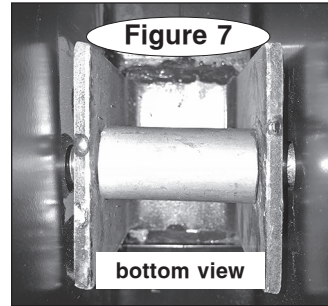

b. With the sticker (Figure 8) facing the outside of the trailer, slide the slipper spring box up and over the equalizer hanger bracket. Align the central slotted hole on the slipper spring box to the hole in the equalizer hanger bracket.

c. The slipper spring box must sit flush against the bottom of the frame. Check for obstructions such as underbelly material, plumbing, etc. and remove or reposition them.

Note: If it's necessary to trim underbelly material, use a utility knife and apply repair tape or other sealing product approved by the trailer manufacturer to seal the cut.

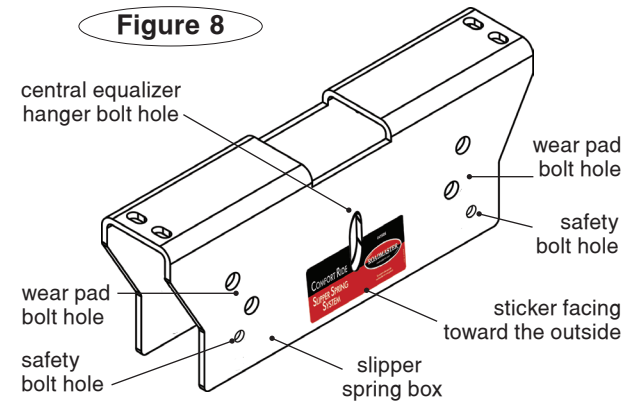

d. Position a 9/16" flat washer over one of the included 9/16" x 4" bolts and insert it through the central hole in the slipper spring box and the 2" pipe spacer. On the opposite side of the slipper spring box, finish with another 9/16" flat washer and 9/16" nylock nut. Leave loose at this time.

Figure 9 shows the slipper spring box.



9. Align the slipper spring box so that it is in line with the trailer's frame rail and centered underneath the frame rail.

Using the pre-existing holes in the top of the slipper spring box as templates, mark and drill four 21/64" diameter holes through the frame rail (Figure 10).

Tech tip: Start your first hole with a small self-drilling screw rather than a drill bit. Use the screw to keep the slipper box centered and properly aligned while you drill the rest of the holes. Don't forget to replace it with one of the included 3/8" self-tapping screws once all the holes have been drilled (step 10).

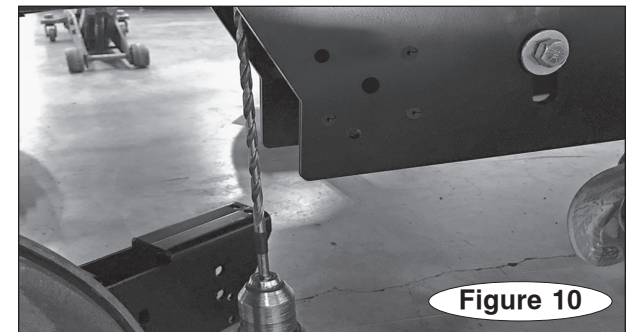

10. Use four of the included 3/8" self-tapping screws to attach the slipper spring box to the frame using the holes you just drilled. Use threadlocker on the screws; tighten to 40 lb-ft.

CAUTION

Do not over torque the screws or they may fail, causing the slipper spring box to separate from the frame. This may cause severe non-warranty damage if the trailer is being towed; other consequential, non-warranty damage may also occur.

continued from preceding page

11. Repeat steps 6 through 10 for the remaining three slipper boxes.

12. Installing the new slipper springs (refer to Figure 8 for the bolt locations):

Working on one side of the trailer at a time:

a. Front axle: Insert the eyelet end of the spring between the flanges of the spring hanger, and reinstall the bolt you removed in step 5 (Figure 11). Drive the bolt home using a hammer to fully re-engage the splines.

Note: Pay particular attention to which direction each spring is installed because it varies by axle. You will be installing the springs in this sequence: front axle, rear axle and then center axle.

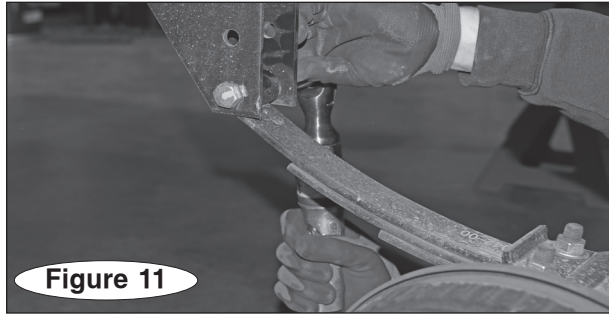

i. Using a cleaner/degreaser, clean and dry the threads on the end of the bolt. Apply Loctite® Red (not included) before proceeding to 12aii.

ii. Reinstall the nut.

⚠ WARNING

The spring bolts must be tightened so that the spring hanger hole rides on the shoulder of the bolt. If the spring hanger hole rides on the threads, the bolt will eventually fail causing severe, non-warranty damage.

The most common axle manufacturers' torque specifications are provided at the end of these instructions. Tighten the bolt to these specifications.

Ensure that the spring can still pivot freely inside the hanger.

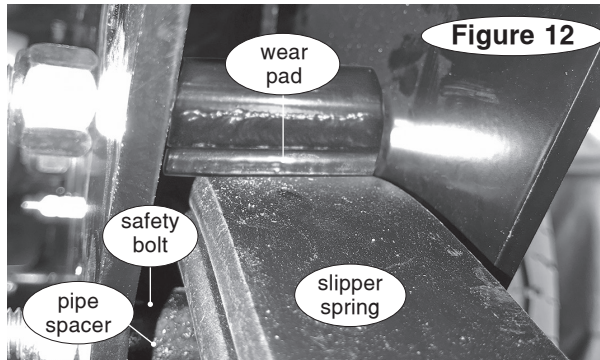

iii. Raise the slipper end of the spring until both ends of the spring are approximately level with each other.

iv. Install the 7/16" safety bolt through the safety bolt hole, through a 2½" pipe spacer, and then through the other side of the slipper spring box. The slipper spring should now be resting on the pipe spacer (Figure 12). Finish with a 7/16" nylock nut and torque to 40 lb-ft.

iv. Place the wear pad inside the slipper spring box and insert a 9/16" x 4" bolt through the wear pad bolt hole, the wear pad, and then out the other side. Finish with a 9/16" nylock nut. **Note:** When positioned correctly, the wear pad will be above the end of the leaf spring. The spring will contact the wear pad once the suspension is loaded (Figure 12).

Torque the bolt to 54 lb-ft. Don't overtighten the bolt but ensure that the wear pad still moves freely.

b. Rear axle:

i. Repeat step 12 for the rear axle. Refer to page 2 for correct orientation.

c. Center axle:

i. Insert the eyelet end of the leaf spring into the slipper spring box located between the front and center axle. Secure the spring eye to the slipper box using a 9/16" x 4" bolt, two 3/8" spacers (one on each side of the spring eye) and a 9/16" nylock nut. Torque it to 54 lb-ft. **Ensure that the spring can still pivot freely inside the hanger.**

⚠ WARNING

The center spring eyelet must be oriented toward the front of the trailer.

ii. Raise the slipper end of the spring until both ends of the spring are approximately level with each other.

iii. Install the 7/16" safety bolt through the safety bolt hole, through a 2½" pipe spacer, and then through the other side of the slipper spring box. The slipper spring should now be resting on the pipe spacer (Figure 12). Finish with a 7/16" nylock nut and torque to 40 lb-ft.

iv. Install the wear pad in the same manner as you did previously.

v. Before proceeding, refer to the images on page 2 and Figure 13 for placement of the anti-rotation plate.

Figure 13

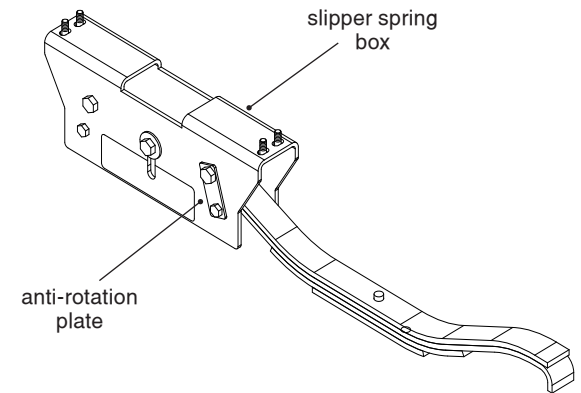

Then, place the hexagonal end of the anti-rotation plate over the head of the 9/16" bolt. **Note:** This is the same bolt used in step 12ci.

vi. Rotate the bolt and anti-rotation plate until the small hole on the anti-rotation plate aligns with the safety bolt hole. Place a 7/16" bolt through the anti-rotation plate, the slipper box, a 2½" pipe spacer and the other side of the slipper box. Finish with a 7/16" nylock nut.

d. Ensure that all bolts have been torqued.

e. Repeat step 12 for the other side of the trailer.

Note: If the trailer has the Correct Track system, check to see if it needs adjustment to align the axles after this installation.

continued on next page

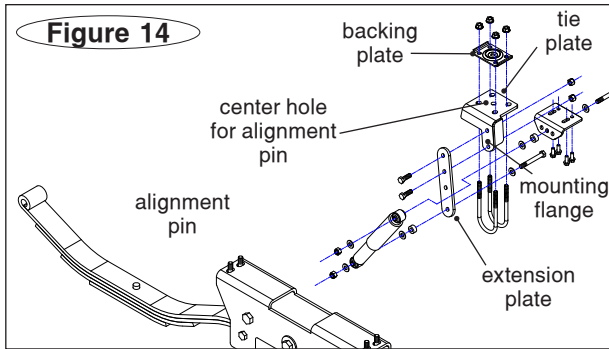

- 13. Install the Comfort Ride Shock Absorbers:**
- a.** Position the tie plate so that the alignment pin on the leaf spring engages the center hole in the tie plate (Figures 14 and 16). Ensure the shock mounting flange faces toward the center of the trailer and is positioned between the axles. Refer to the drawing on page 1 to better understand how the parts attach to each other.
 - b.** Install the U-bolts through the tie plate and included backing plate; finger tighten the U-bolt nuts. (Figure 15).

IMPORTANT! When installing the tie plates, position the axle so that the alignment pins (shown in green, Figure 16) are seated against the tie plate (top view, Figure 16). Verify that it is the same on both sides AND on both axles. Failure to align the pins in this manner may result in an out-of-alignment axle, causing non-warranty tire wear.

Once the axle is positioned as described above, torque the U-bolts and nuts to 130 lb-ft.

- 14.** Reinstall the wheels and tires, remove all jack stands and slowly lower the trailer. Make certain that the flat side of the wear pad is touching the slipper spring when the suspension is fully loaded. If not, reposition the wear pad to accomplish this.

CAUTION

Ensure that the suspension is fully loaded, i.e., bearing the weight of the trailer, before installing the shock absorbers. Otherwise, the shock absorbers will be at the wrong length once installed. The shock absorbers, as well as the trailer, may

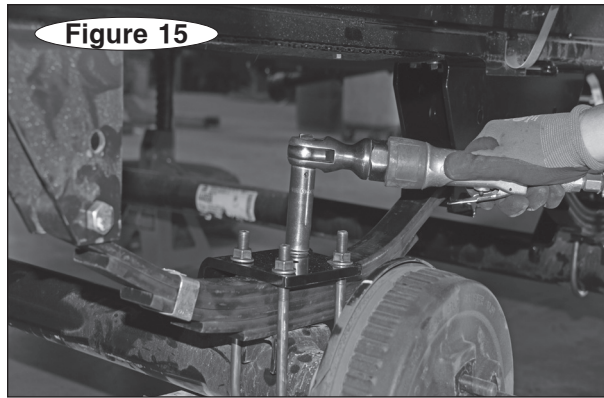

may be damaged. Other collateral, non-warranty damage may also occur.

- 15.** Installing the shock absorbers to the slipper spring boxes (Figure 17):
- a.** Place a 12mm washer over a 12mm x 1.75 x 100mm bolt. Bolt through the top of the shock absorber, 12mm washer, a spacer, wedge washer (in green) and the slipper spring box. *Note: The shock must be installed with the wider portion of the shock at top.*
 - b.** Finish with another wedge washer (in green), 12mm flat washer and 12mm nylock nut.
 - c.** Tighten the 12mm bolt and nut just enough so that the wedge washers will stay in place when you rotate them. (The wedge washers will be rotated, and the shock mounting bolts torqued, in a later step).

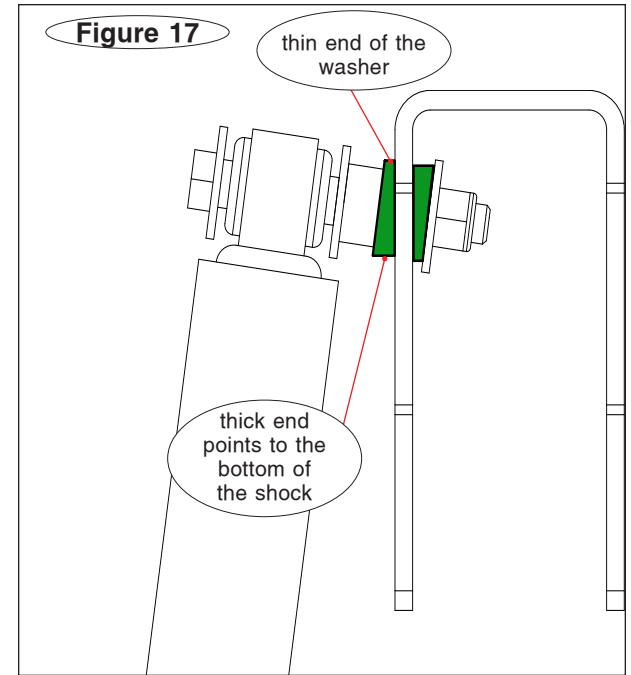

- d.** Repeat for the remaining shock absorbers.

continued on next page

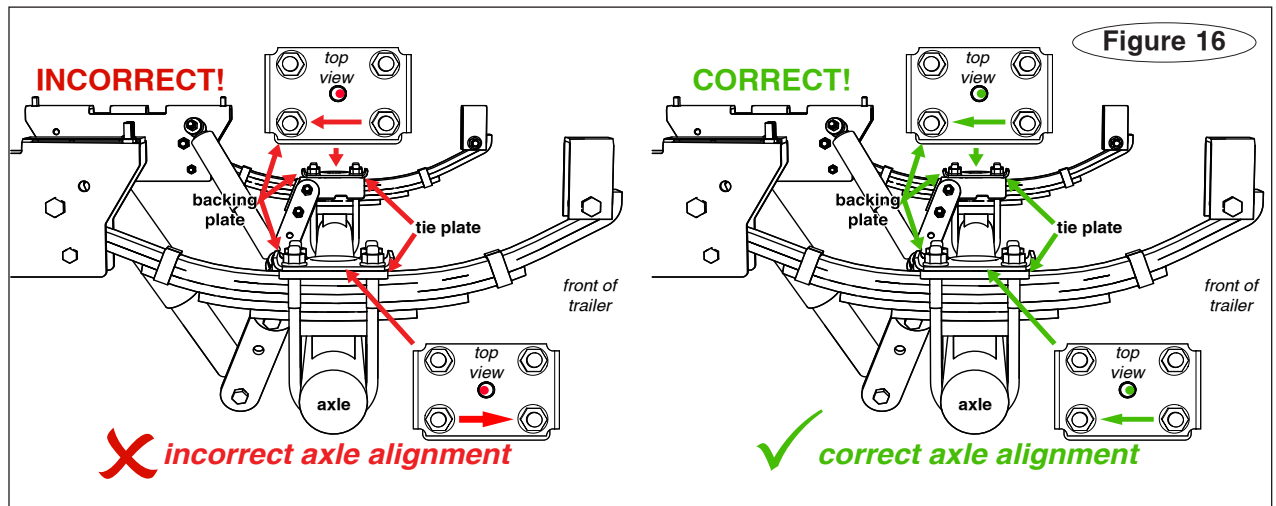

16. Mounting the shock absorbers to the mounting flanges or extension plates:

a. The purpose of the restraining bands on the shock absorbers is to hold them at a fixed length. This length will dictate where the bottom of the shock absorbers should be fastened.

NOTE

If the restraining bands are damaged or cut, restrain the shock absorbers at a 14½" length, hole-center to hole-center.

I. The final mounting location must be between 20 and 40 degrees (Figure 19).

II. Determine which option shown in Figure 18 places the bottom hole of the shock absorber closest to a mounting hole. If A or B, secure the extension plate with the provided yellow zinc grade 8 bolts and locknuts. It is important that the shocks are attached to the closest hole to their restrained 14-1/2" length;

III. If the existing drilled options do not align, use the shock absorber as a template and drill a new hole to accommodate it. **It is critically important to ensure that any hole you drill is at least ½" away from any other hole.**

CAUTION

Make sure the shock absorber extension plate doesn't extend below the level of the wheel rim. If it does, the plate or the shock absorber could be damaged in the event of a flat tire. Other consequential, non-warranty damage may also occur.

b. Position a 12mm washer over one of the included 12mm x 1.75 x 100mm bolts. Bolt through the extension plate, a spacer, 12mm washer and the bottom of the shock absorber. Finish with another 12mm washer and a 12mm nylock nut. Leave loose at this time.

c. Repeat for the remaining shock absorbers.

17. Referring to Figure 17, verify the wedge washer orientation:

a. On the **INSIDE** of the slipper box, rotate the wedge washer so that the thin end points **DOWN, in line with the body of the shock.**

b. On the **OUTSIDE** of the slipper box, rotate the wedge washer so that the thick end points **DOWN, in line with the body of the shock.**

NOTE

The wedge washers provide a flat surface for mounting the shock while spacing the shock away from the slipper spring box.

CAUTION

If the wedge washers aren't positioned as described above, the shock absorbers may be damaged. Other consequential, non-warranty damage may also occur.

e. Tighten all shock absorber mounting bolts to 55 lb-ft. Remove the restraining bands from the shock absorbers.

f. Ensure that all bolts are torqued for the slipper springs and the shock absorbers.

18. IMPORTANT! The U-bolts and leaf-spring stack will "settle" as the trailer is used. This settling slightly reduces clamping force, which can allow axle movement if not corrected. Accordingly, **after the trailer has been towed 100 miles, you must check and re-torque the U-bolts to 130 lb-ft.**

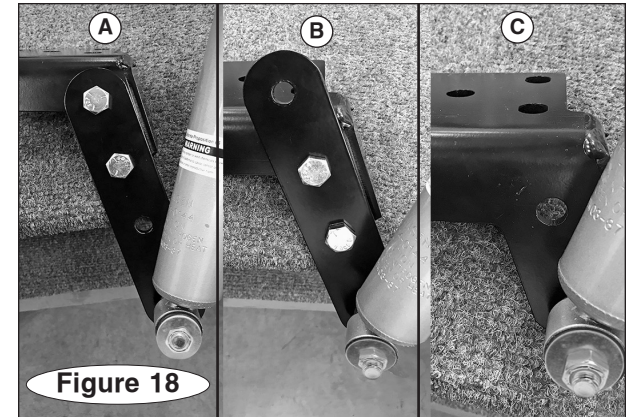

Figure 18

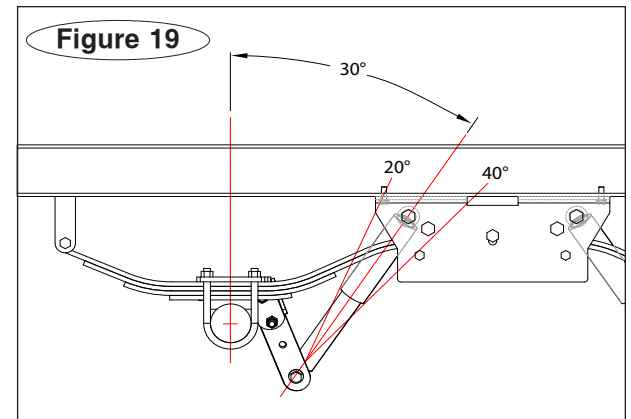

Figure 19