



# Installation Instructions

*Thank you for purchasing this anti-sway bar kit. Please read through these instructions before installation.*

## Front Anti-Sway Bar Kit for 1975-91 Ford E350 Van, RV

part #1139-100  
1-3/8" diameter

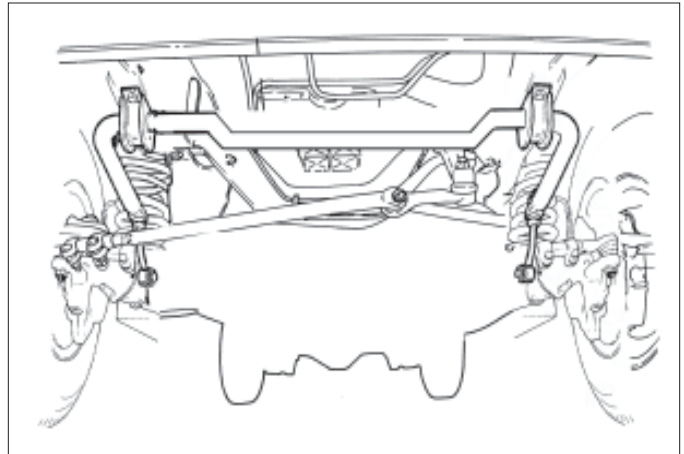

## INTRODUCTION

Thank you for purchasing this anti-sway bar kit. This kit is designed to improve the handling characteristics of your Ford E350 by reducing the body roll and balancing the weight transfer during cornering. The anti-sway bar kit is engineered for long life and trouble-free performance. For maximum suspension control, use this kit along with our rear anti-sway bar kit.

All the hardware needed for installation is included in this kit. Refer to the PARTS LIST in these instructions to identify the parts.

## SUGGESTED TOOLS

The following tools are suggested to complete the installation procedures:

- 9/16" open-end wrench
- General hand tools
- Jack and jack stands (2)
- Socket wrench
- 9/16" socket

## WARNING

- If raising the vehicle to install the anti-sway bar, always support the vehicle with jack stands at both frame rails or at the rear axle before working underneath. Ensure that the jack stands are securely positioned, and are rated at or above the weight of the vehicle.
- The installer must read the instructions and use all bolts and parts supplied. Use only the parts supplied by ROADMASTER to install this kit.
- Minor modifications are sometimes necessary due to slight vehicle variations, even for the same year, make and model.
- If running changes were made by the manufacturer after this kit was designed, there may be weldments, braces, gussets, or other structural items which interfere with the installation. It is the installer's responsibility to allow for these running changes without sacrificing the structural integrity of the anti-sway bar. Failure to securely fasten the anti-sway bar could result in property damage, personal injury or even death.
- ROADMASTER will not be responsible for any damage or injury resulting from any modification or alteration.
- Check ALL the fasteners for tightness before and after road testing the vehicle.
- Do not use this document for custom fabrication, as it may not show all parts or structural components.
- Do not use an air impact wrench when re-installing bolts, as stripped threads may result.
- This anti-sway bar is only warranted for the original installation. Installing a used anti-sway bar on another vehicle is not recommended and will void the warranty.

## WARNING

**Failure to follow these instructions can result in property damage, personal injury or even death.**

# PARTS LIST

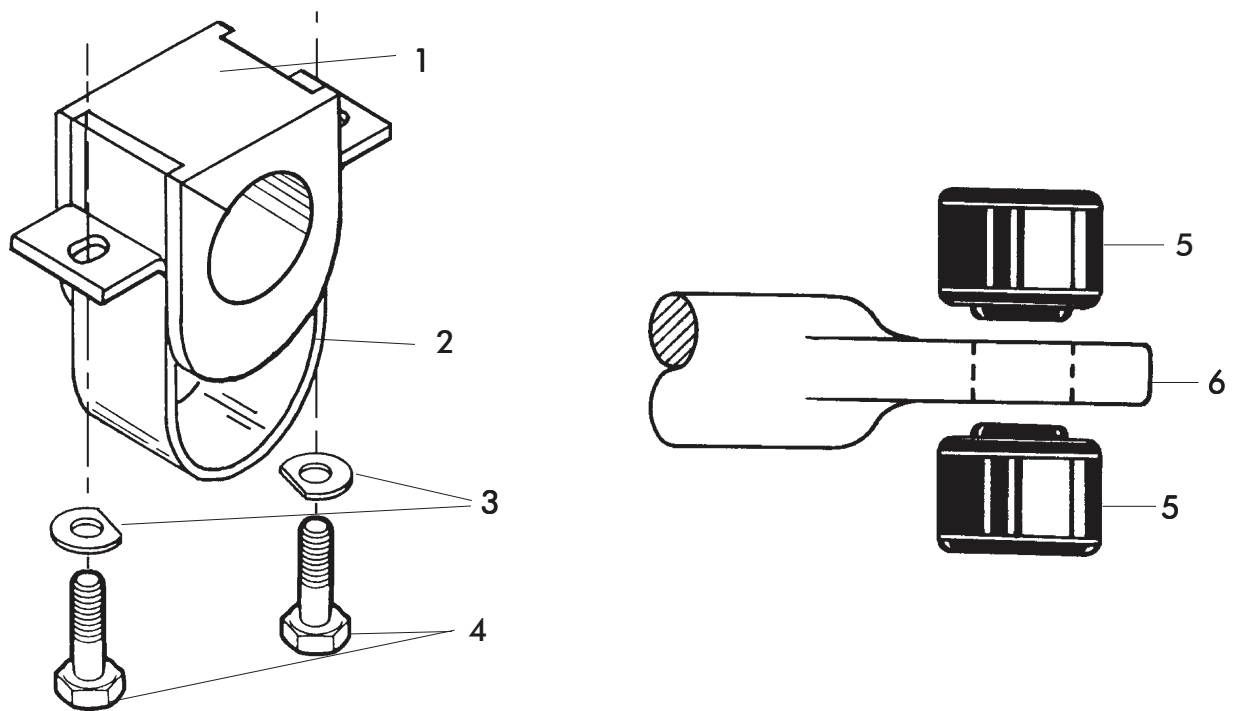

Part #1139-100

Part #	Description	Qty
1. 205219-10	Bushing, split poly 1-3/8"	2
2. B140	Bracket, saddle	2
3. 350304-30	Washer, "D" cut	4
4. 350055-00	Bolt, 3/8" x 1"	4
5. 205381-00	Grommet	4
6. 580050-00	Sway bar, 1-3/8"	1
7. 400011-30	AQUALUBE Grease	1

# INSTALLATION

The following instructions must be followed in the order listed to ensure a proper installation and to preserve the ROADMASTER warranty.

**1. Remove the nut and grommets from the links.**

Use a 9/16" wrench or socket to remove the nut from the top of each link assembly. Remove the upper grommets and washers. Lift the ends of the anti-sway bar and remove the lower grommets.

**2. Remove the bolts from the saddle brackets.**

Support the front of the anti-sway bar with tall jack stands so that it will not fall when the saddle brackets are removed. The anti-sway bar weighs approximately 30 pounds so be careful when removing it from the frame.

**⚠ WARNING**

The anti-sway bar is heavy, and may cause property damage or personal injury if it falls on equipment, engine components or any part of your body. Ensure that the anti-sway bar is supported and that you are out of the way when removing the brackets.

**3. Lubricate the bushings with the provided grease.**

Put a thorough coat of grease on the inside of each bushing (Figure 1).

**4. Place the bushings on the anti-sway bar.**

Install the bushings over the anti-sway bar near the bends for the arms. Install the saddle brackets over the bushings on the anti-sway bar.

**5. Mount the anti-sway bar to the frame.**

Support the anti-sway bar on the jack stands and install the "D" washers and bolts to hold the saddle bracket assemblies to the frame (Figure 2). Tighten the bolts to 30 ft.-lbs.

**6. Assemble the links.**

Install a grommet on each link with the raised part of the grommet facing up.

Figure 1

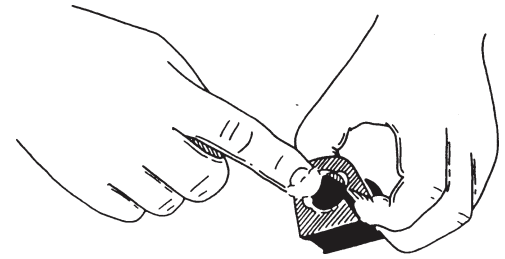
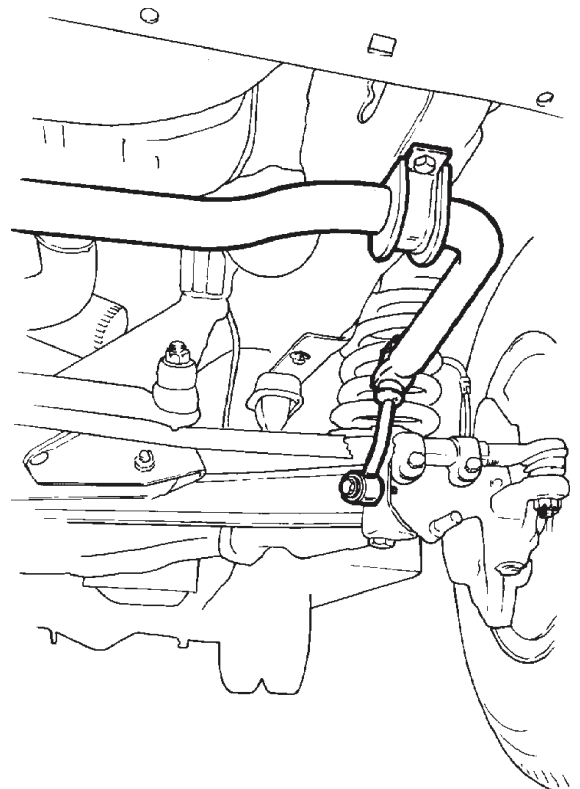

Figure 2



# INSTALLATION

The following instructions must be followed in the order listed to ensure a proper installation and to preserve the ROADMASTER warranty.

## 7. Install the anti-sway bar ends on the links (Figure 3).

Swing the anti-sway bar so that the hole in the end of the arm is aligned with the threads on the link. Install the upper grommet, cup washer and nut. Tighten the nut snug, just so the grommets will not spin (Figure 4). Assemble and tighten the other link.

### **WARNING**

Over-tightening the grommets may cause premature failure of the grommets and/or the end links. If the grommets fail, the anti-sway bar will not stabilize the vehicle at full capacity, which may cause reduced cornering ability or other reductions in vehicle handling or performance.

Failure to follow these instructions may result in property damage, personal injury or even death.

## 8. Test drive and re-inspect installation.

After road testing, re-check all fasteners for proper tightness.

### **WARNING**

After road testing, re-check all fasteners for proper tightness — if a fastener has worked loose or fallen off, re-tighten or replace it. Without all kit components properly tightened or in place, the anti-sway bar will not stabilize the vehicle at full capacity, which may cause reduced cornering ability or other reductions in vehicle handling or performance.

Failure to follow these instructions may result in property damage, personal injury or even death.

### **WARNING**

#### The anti-sway bar is not a load-bearing component

Do not tow or hoist the vehicle using the anti-sway bar or its mounting brackets as attachment points. The anti-sway bar is not designed to carry the weight of the vehicle and may collapse, which will damage the anti-sway bar components, the suspension, or other components. The vehicle will detach or fall, which may cause severe personal injury.

Failure to follow these instructions may result in property damage, personal injury or even death.

Figure 3

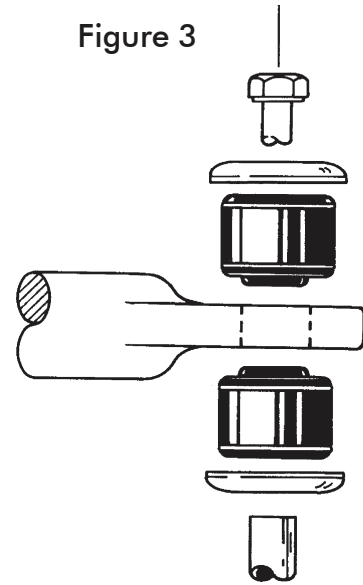

Figure 4

