



Installation Instructions

Thank you for purchasing this anti-sway bar kit. Please read through these instructions before installation.

Rear Anti-Sway Bar Kit for Ford E350 w/ Autochains

part #1139-134
1-1/8" diameter

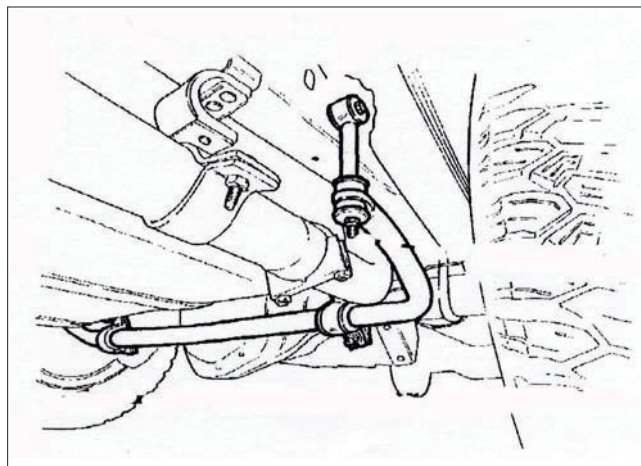

INTRODUCTION

Thank you for purchasing this anti-sway bar kit. This kit is designed to improve the handling characteristics of your Ford E-350 w/ Auto chains by reducing the body roll and balancing the weight transfer during cornering. The anti-sway bar kit is engineered for long life and trouble-free performance. For maximum suspension control, use this kit along with our front anti-sway bar kit.

All the hardware needed for installation is included in this kit. Refer to the PARTS LIST in these instructions to identify the parts.

SUGGESTED TOOLS

The following tools are suggested to complete the installation procedures:

- Wrenches - 5/8" & 3/4"
- Sockets - 9/16" & 3/4"
- Jack Stands (2)
- Electric Drill
- Drill Bits - 1/8" & 1/2"
- General Hand Tools
- Lug Wrench
- Floor Jack (5 ton)
- Socket Wrench

WARNING

- If raising the vehicle to install the anti-sway bar, always support the vehicle with jack stands at both frame rails or at the rear axle before working underneath. Ensure that the jack stands are securely positioned, and are rated at or above the weight of the vehicle.
- The installer must read the instructions and use all bolts and parts supplied. Use only the parts supplied by ROADMASTER to install this kit.
- Minor modifications are sometimes necessary due to slight vehicle variations, even for the same year, make and model.
- If running changes were made by the manufacturer after this kit was designed, there may be weldments, braces, gussets, or other structural items which interfere with the installation. It is the installer's responsibility to allow for these running changes without sacrificing the structural integrity of the anti-sway bar. Failure to securely fasten the anti-sway bar could result in property damage,

personal injury or even death.

- ROADMASTER will not be responsible for any damage or injury resulting from any modification or alteration.
- Check ALL the fasteners for tightness before and after road testing the vehicle.
- Do not use this document for custom fabrication, as it may not show all parts or structural components.
- Do not use an air impact wrench when re-installing bolts, as stripped threads may result.
- This anti-sway bar is only warranted for the original installation. Installing a used anti-sway bar on another vehicle is not recommended and will void the warranty.

WARNING

Failure to follow these instructions can result in property damage, personal injury or even death.

PARTS LIST

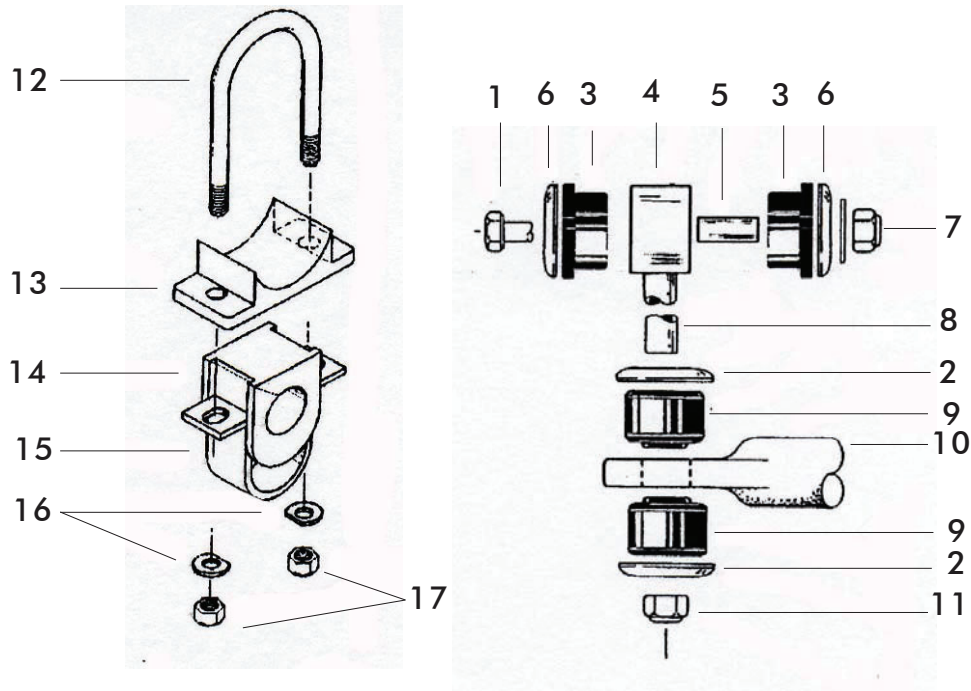

Part #1139-134

Part #	Description	Qty	Part #	Description	Qty
1. 350099-80	Bolt, link 1/2" x 2-1/2"	2	10. 580071-00	Sway bar, 1-1/8"	4
2. 357434-00	Washer, cup	4	11. 350256-02	Locknut, 7/16" NC	2
3. 205223-00	Bushing, link	4	12. 357359-00	U-bolt	2
4. B226	Link	2	13. 480013	Bracket, flat	2
5. 205501-00	Sleeve, bushing 1/2 x 1-3/8"	4	14. 205218-10	Bushing, poly	2
6. 350347-00	Washer, cut	4	15. B141	Bracket, saddle	2
7. 350259-00	Locknut, 1/2" NC	2	16. 350308-00	Washer D	4
8. 205502-00	Sleeve, link 3/4" x 4"	2	17. 350259-01	Locknut 1/2" NF	4
9. 205381-00	Grommet	4	18. 400011-30	AQUALUBE Grease	1

INSTALLATION

The following instructions must be followed in the order listed to ensure a proper installation and to preserve the ROADMASTER warranty.

1. Support the vehicle and remove the rear wheels (optional).

a. Use a floor jack to raise the vehicle.

Put the vehicle in neutral. Put a floor jack under the frame and raise the vehicle so that the tires are off the floor.

b. Put jack stands under the frame.

Place the jack stands under the rear axle housing to correctly locate the mounting point for the links. Lower the axle housing onto the jack stands. Push the side of the body to make sure that the vehicle is stable.

! WARNING

If raising the vehicle to install the anti-sway bar, always support the vehicle with jack stands at both frame rails or at the rear axle before working underneath. Ensure that the jack stands are securely positioned, and are rated at or above the weight of the vehicle.

2. Loosely mount the anti-sway bar to the rear axle housing.

a. Install the U-bolts for the anti-sway bar mounts.

Install each U-bolt about 6" inboard of the springs on the axle housing. Use a screwdriver to bend the brake lines away from the axle so that the U-bolts will fit between the brake lines and the axle housing. Insert the U-bolts from the front.

! WARNING

The brake line will need to be pried away from the axle tubes. DO NOT clamp over the brake line. Also DO NOT kink brake line. If the brake line is clamped, or kinked, the vehicle brakes may fail. Failure to follow these instructions can result in property damage, personal injury or even death.

b. Install the assembly on the axle housing.

Lubricate the inside of the split bushing with the provided lubricant. Install the split bushings on the anti-sway bar and slide the saddle brackets over the split bushings. Install the U-bolt flat bracket on the U-bolt. Position the anti-sway bar so that the arms are toward the rear and the bend in the center is down. Lift the anti-sway bar/bushing assembly to the axle housing and install the washers and nuts on the U-bolts. Do not tighten at this time.

3. Drill holes in frame for link bolts.

a. Install link assemblies on the anti-sway bar ends.

Install the cup washers, grommets, link sleeves and links to the anti-sway bar. Install and tighten the nut to 10 ft.-lbs.

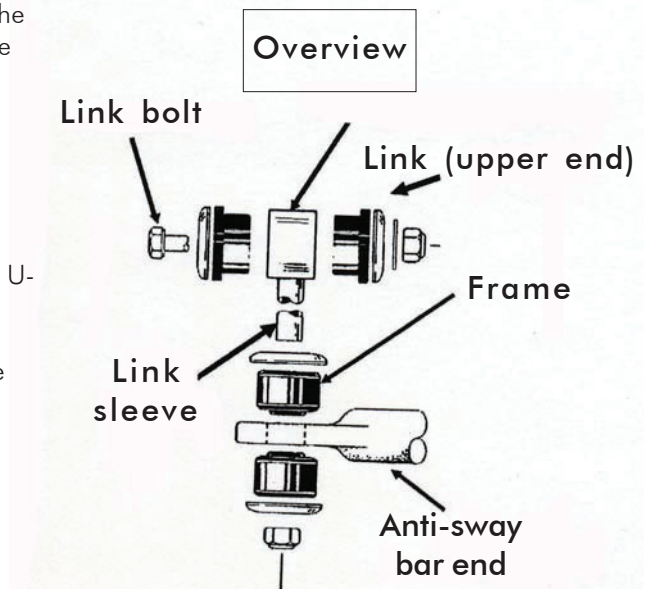
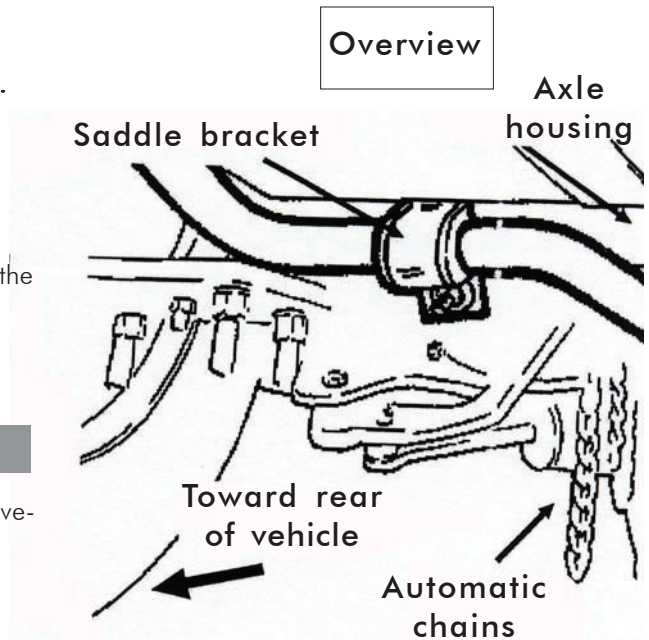

INSTALLATION

b. Move the anti-sway bar assembly until the link is vertical.

Swing the anti-sway bar arms upward until the hole in the link is about parallel to the ground, or frame rail. Pivot the U-bolt mounts on the axle housing until each link is vertical and touching the outboard surface of the frame rail. Tighten the U-bolt nuts enough to maintain this position. Use a punch to mark the frame rail at the center of the link hole.

c. Drill the holes for mounting the links to the frame.

Use the 1/8" drill bit to start the hole for the link bolt. Finish the hole with the 1/2" drill bit.

4. Mount the upper links to the frame.

a. Install the bushings in the upper links.

Install the bushings in the hole in the links. Install the sleeves in the bushings.

b. Fasten the link to the frame rail.

Install a cup washer on the link bolt. Hold a cup washer between the upper link and the frame and insert the bolt through the link bushings and frame rail. Install the flat washer and lock nut from the inboard side of the frame rail. Repeat for the other side.

5. Install the wheels, test drive and check fasteners.

a. Adjust the position of the U-bolts and tighten the nuts.

Make sure that the links are vertical and adjust the position of the U-bolt mounts if necessary. Tighten the U-bolt nuts to 20 ft.-lbs., the lower link nuts to 10 ft.-lbs. and the upper link nuts to 30 ft.-lbs.

WARNING

Over-tightening the grommets may cause premature failure of the grommets and/or the end links. If the grommets fail, the anti-sway bar will not stabilize the vehicle at full capacity, which may cause reduced cornering ability or other reductions in vehicle handling or performance.

Failure to follow these instructions may result in property damage, personal injury or even death.

b. Remove jacks and re-torque lug nuts.

If you raised the vehicle and removed the wheels, re-install the wheels and remove floor jacks. Tighten the lug nuts to the factory torque specifications.

Overview

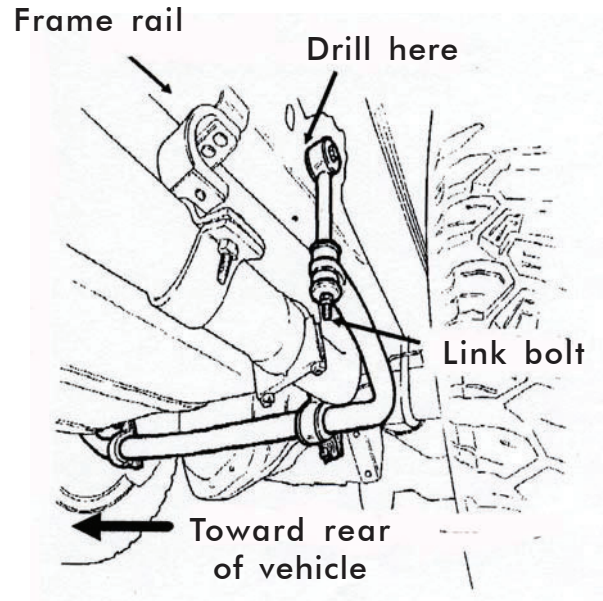
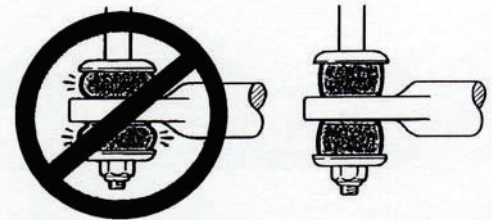

Figure 4



c. Test drive and listen for noise.

WARNING

After road testing, re-check all fasteners for proper tightness — if a fastener has worked loose or fallen off, re-tighten or replace it. Without all kit components properly tightened or in place, the anti-sway bar will not stabilize the vehicle at full capacity, which may cause reduced cornering ability or other reductions in vehicle handling or performance.

Failure to follow these instructions may result in property damage, personal injury or even death.

WARNING

The anti-sway bar is not a load-bearing component

Do not tow or hoist the vehicle using the anti-sway bar or its mounting brackets as attachment points. The anti-sway bar is not designed to carry the weight of the vehicle and may collapse, which will damage the anti-sway bar components, the suspension, or other components. The vehicle will detach or fall, which may cause severe personal injury.

Failure to follow these instructions may result in property damage, personal injury or even death.