



Installation Instructions

Thank you for purchasing this anti-sway bar kit. Please read through these instructions before installation.

Ford F150 Rear Anti-Sway Bar Kit for 2004-2006

part #1139-152
1-1/8" diameter

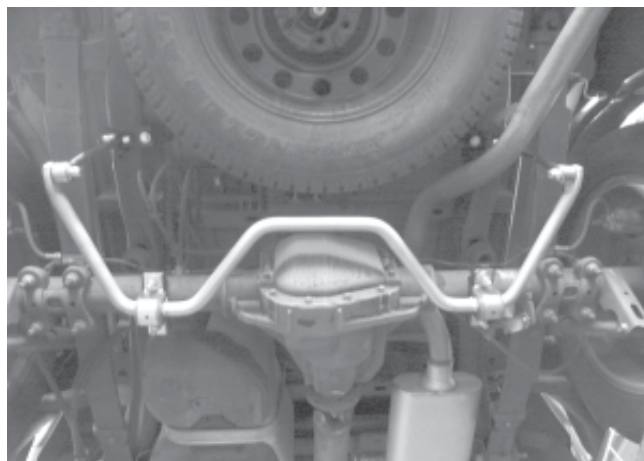

INTRODUCTION

Thank you for purchasing the rear sway bar kit. This kit is designed to improve the handling characteristics of your Ford F150 by reducing the body roll and balancing the weight transfer during cornering. The sway bar kit is engineered for long life and trouble-free performance.

All the hardware needed for installation is included in this kit. Refer to the PARTS LIST in these instructions to identify the parts.

SUGGESTED TOOLS

The following tools are suggested to complete the installation procedures:

- General hand tools

WARNING

- If raising the vehicle to install the anti-sway bar, always support the vehicle with jack stands at both frame rails or at the rear axle before working underneath. Ensure that the jack stands are securely positioned, and are rated at or above the weight of the vehicle.
- The installer must read the instructions and use all bolts and parts supplied. Use only the parts supplied by ROADMASTER to install this kit.
- Minor modifications are sometimes necessary due to slight vehicle variations, even for the same year, make and model.
- If running changes were made by the manufacturer after this kit was designed, there may be weldments, braces, gussets, or other structural items which interfere with the installation. It is the installer's responsibility to allow for these running changes without sacrificing the structural integrity of the anti-sway bar. Failure to securely fasten the anti-sway bar could result in property damage, personal injury or even death.
- ROADMASTER will not be responsible for any damage or injury resulting from any modification or alteration.
- Check ALL the fasteners for tightness before and after road testing the vehicle.
- Do not use this document for custom fabrication, as it may not show all parts or structural components.
- Do not use an air impact wrench when re-installing bolts, as stripped threads may result.
- This anti-sway bar is only warranted for the original installation. Installing a used anti-sway bar on another vehicle is not recommended and will void the warranty.

WARNING

Failure to follow these instructions can result in property damage, personal injury or even death.

PARTS LIST

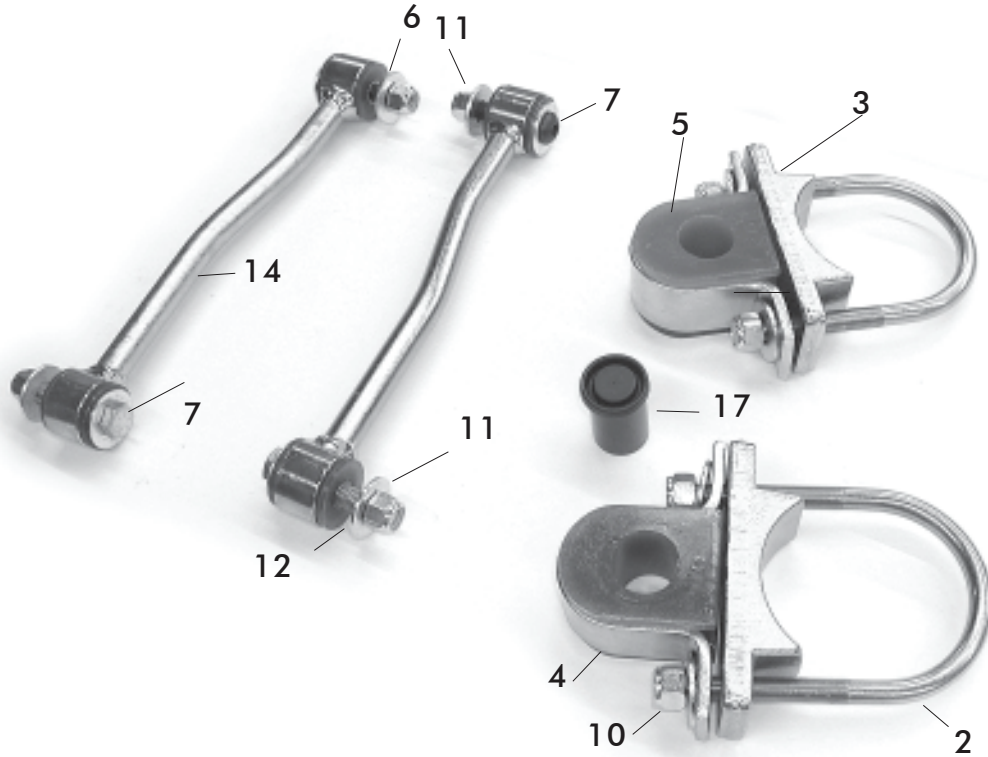

Part #1139-152

Part #	Description	Qty	Part #	Description	Qty
1.	580179-00 Rear sway bar	1	10.	350259-01 Nylock nut, fine	4
2.	357359-00 U-bolt	2	11.	350259-00 Nylock nut, coarse	4
3.	480013 Cast axle bracket	2	12.	350308-00 Washer	6
4.	B141 Bushing clamp	2	13.	205510-00 Sleeve	4
5.	205218-10 Poly bushing	2	14.	B410 Endlink	2
6.	205223-00 Hat bushing	8	15.	350088-88 7/16" x 6" UNC Bolt	2
7.	350101-80 Bolt, 1/2" x 3"	4	16.	350256-02 7/16" NC Locknut	2
8.	B543 Endlink bracket	2	17.	400011-30 Aqualube - Grease	1
9.	350304-80 3/8" Cut washers	4			

INSTALLATION

The following instructions must be followed in the order listed to ensure a proper installation and to preserve the ROADMASTER warranty.

1. Raise the rear of the vehicle, remove the rear tires and place jackstands under the rear axle. An ideal stand location is at the outmost point under the spring plates (optional).
2. Lube the bushings and install them on the anti-sway bar near the 90-degree bend. Put the u-brackets on the bushings (Figure 1).
3. Install u-bolts on the axle tube just inside of the shock brackets. Be sure to slip the u-bolt under any brake lines (Figure 2). *Note:* it may be necessary to pry up the clip that holds the brakeline onto the passenger side.
4. Put cast brackets onto u-bolts.
Hint: two large rubber bands are helpful in holding the cast brackets in place while the anti-sway bar is being lifted into place.
5. Raise the bar into place (Figure 1).
Note: the arms of the bar face the rear of the vehicle. Secure it using the washers and nuts provided.
6. Assemble the endlinks using bushings and sleeves (Figure 3). Mount the endlink loosely to the inner side of the anti-sway bar using the supplied hex head bolts, washers and nuts. The shortest straight section of the end link is attached to the frame.

Figure 1

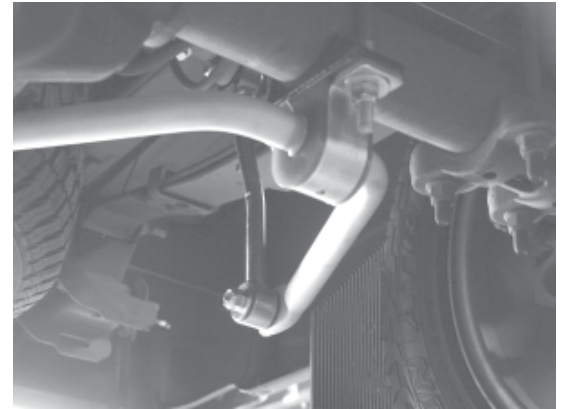

Figure 2

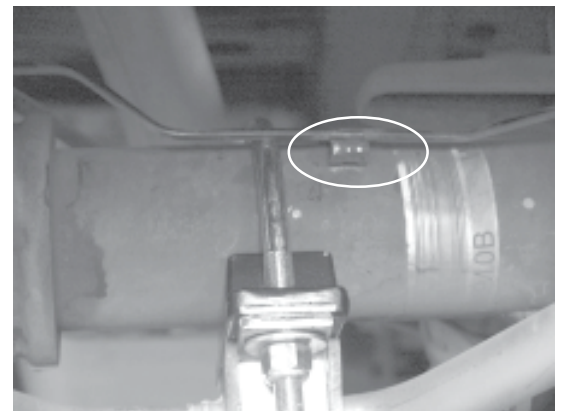
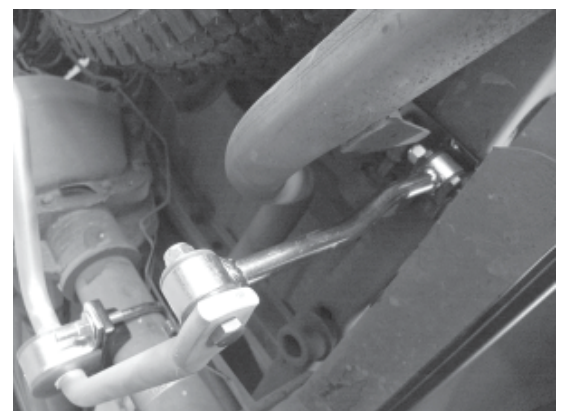

Figure 3



INSTALLATION

The following instructions must be followed in the order listed to ensure a proper installation and to preserve the ROADMASTER warranty.

7. Mount the frame/endlink bracket to the frame rail using 7/16" bolts, nuts and washers, as shown in Figure 4 and 5, torque to 40-45 ft.lbs. Install the endlink to the bar and bracket, then torque to 40-45 ft.lbs.
8. Reinstall the wheels and lower the vehicle.
9. Road test. Listen for noises. Reinspect fasteners.

Figure 4

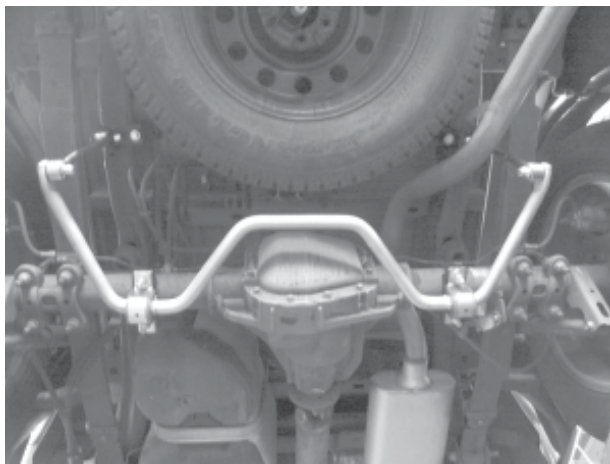
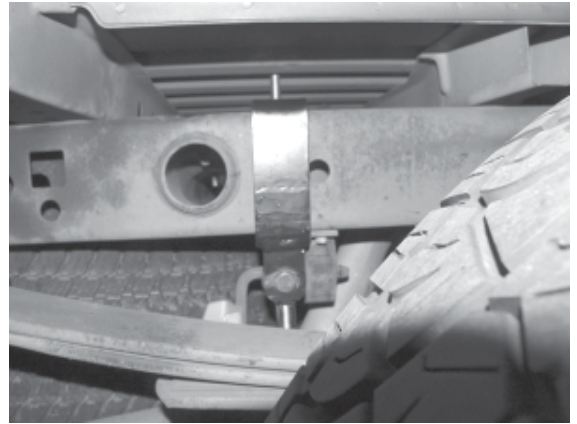

Figure 5



WARNING

The anti-sway bar is not a load-bearing component

Do not tow or hoist the vehicle using the anti-sway bar or its mounting brackets as attachment points. The anti-sway bar is not designed to carry the weight of the vehicle and may collapse, which will damage the anti-sway bar components, the suspension, or other components. The vehicle will detach or fall, which may cause severe personal injury.

Failure to follow these instructions may result in property damage, personal injury or even death.