



Thank you for purchasing this anti-sway bar kit. Please read through these

Installation Instructions

Front Anti-Sway Bar Kit for Ford F-450/550 (2004-on)

part #1139-157 1-3/8" diameter



INTRODUCTION

Thank you for purchasing this anti-sway bar kit. This kit is designed to improve the handling characteristics of your Ford F350 by reducing the body roll and balancing the weight transfer during cornering. The anti-sway bar kit is engineered for long life and trouble-free performance. For maximum suspension control, use this kit along with our rear anti-sway bar kit.

All the hardware needed for installation is included in this kit. Refer to the PARTS LIST in these instructions to identify the parts.

SUGGESTED TOOLS

The following tools are suggested to complete the installation procedures:

- General hand tools

WARNING

Failure to follow these instructions can result in property damage, personal injury or even death.

- If raising the vehicle to install the anti-sway bar, always support the vehicle with jack stands at both frame rails or at the rear axle before working underneath. Ensure that the jack stands are securely positioned, and are rated at or above the weight of the vehicle.
- The installer must read the instructions and use all bolts and parts supplied. Use only the parts supplied by ROADMASTER to install this kit.
- Minor modifications are sometimes necessary due to slight vehicle variations, even for the same year, make and model.
- Regardless of year, make and model, a wide range of options for specific applications may or may not interfere with the installation. It is the installer's responsibility to make certain that equipment is not damaged once the suspension solution travels through the full range of motion. Failure to ensure adequate clearance could result in non-warranty property damage, personal injury or even death.
- If running changes were made by the manufacturer after this kit was designed, there may be weldments, braces, gussets, or other structural items which interfere with the installation. It is the installer's responsibility to allow for these running changes without sacrificing the structural integrity of the anti-sway bar. Failure to securely fasten the anti-sway bar could result in property damage, personal injury or even death.
- ROADMASTER will not be responsible for any damage or injury resulting from any modification or alteration.
- Check ALL the fasteners for tightness before and after road testing the vehicle.
- Do not use this document for custom fabrication, as it may not show all parts or structural components.
- Do not use an air impact wrench when re-installing bolts, as stripped threads may result.
- This anti-sway bar is only warranted for the original installation. Installing a used anti-sway bar on another vehicle is not recommended and will void the warranty.

PARTS LIST

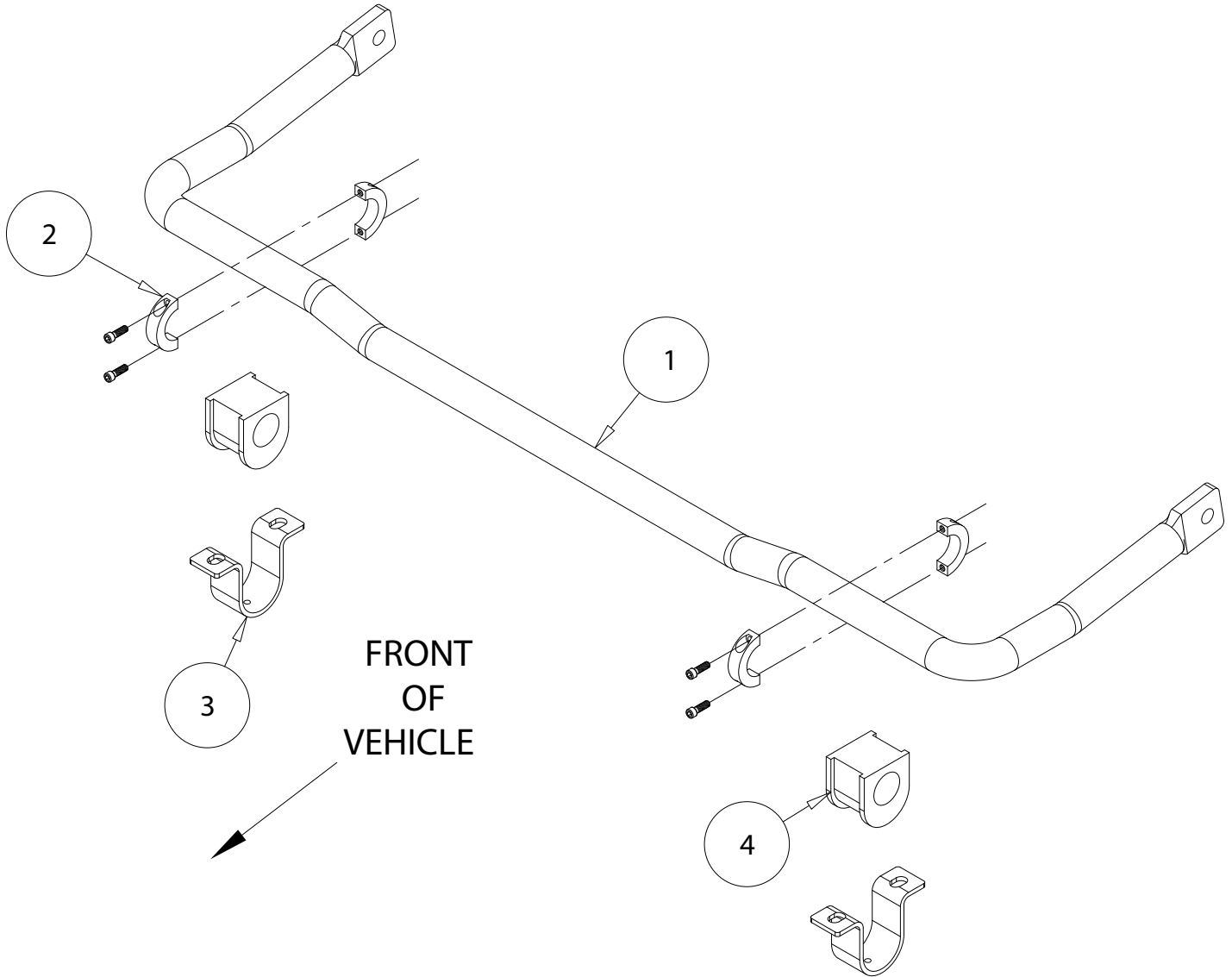

ITEM.....	QTY.....	DESCRIPTION	PART.....
1.....	1	FRONT SWAY BAR.....	580059-00
2.....	2	RETAINING COLLAR	350530-00
3.....	2	BUSHING CLAMP	B140
4.....	2	SPLIT BUSHING	205225-10
5.....	1	THREADLOCKER	400011-30

INSTALLATION

The following instructions must be followed in the order listed to ensure a proper installation and to preserve the ROADMASTER warranty.

1. Remove the factory anti-sway bar.

Disconnect the anti-sway bar from the endlinks (leave the factory end links attached to the vehicle for reuse) and remove the four bolts holding the bushing clamps. The anti-sway bar is heavy so use caution when unbolting the brackets that hold it. Get someone to help you, if possible. Loosen brackets on the end link first, then frame brackets.

WARNING

Removing the endlinks will release the anti-sway bar. The anti-sway bar is heavy, and may cause property damage or personal injury if it falls on equipment, engine components or any part of your body. Ensure that the anti-sway bar is supported and that you are out of the way when removing the brackets.

Failure to follow these instructions may cause property damage, personal injury or even death.

2. Lubricate the bushings with the provided grease.

Put a thorough coat of grease on the inside of each bushing (Figure 1.)

3. Place the bushings on the anti-sway bar.

Use the factory anti-sway bar to determine proper location for the bushings.

4. Push the brackets over the bushings.

5. Lift the anti-sway bar into place and attach the endlinks and the bushing clamps.

Lift the anti-sway bar into place, setting the end brackets onto the endlink. Then, lift the center into place and drop the bolts with washers through from the top. Start the nuts with D washers onto bolts. Drop the bolts with D washers through the end brackets. Start the nuts with washers onto the bolts (Figure 2).

6. Center the anti-sway bar and mount the retaining collar on the inside of the bushing.

Tighten the bolts halfway. Check the anti-sway bar to be certain it is centered. Now, torque all bolts to 30-35 ft.-lbs. (Figure 3).

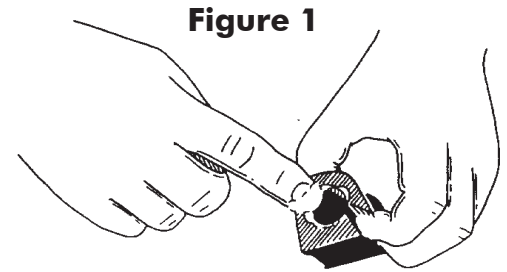

Figure 2



Figure 3



INSTALLATION

The following instructions must be followed in the order listed to ensure a proper installation and to preserve the ROADMASTER warranty.

7. Test drive the vehicle.

After road testing, re-check all fasteners for proper tightness.

WARNING

After road testing, re-check all fasteners for proper tightness — if a fastener has worked loose or fallen off, re-tighten or replace it. Without all kit components properly tightened or in place, the anti-sway bar will not stabilize the vehicle at full capacity, which may cause reduced cornering ability or other reductions in vehicle handling or performance.

Failure to follow these instructions may result in property damage, personal injury or even death.



WARNING

The anti-sway bar is not a load-bearing component

Do not tow or hoist the vehicle using the anti-sway bar or its mounting brackets as attachment points. The anti-sway bar is not designed to carry the weight of the vehicle and may collapse, which will damage the anti-sway bar components, the suspension, or other components. The vehicle will detach or fall, which may cause severe personal injury.

Failure to follow these instructions may result in property damage, personal injury or even death.